

“TOMORROW’S ROADS TODAY” EXPRESSWAY CONSTRUCTION IN MARYLAND, 1948-1965

**Historic Context and Survey of SHA Bridges
Statewide with Determination of Eligibility Forms
SHA Project No. SP0310C42**



**Maryland State Highway Administration
707 North Calvert Street, Baltimore, MD 21202**

**Prepared By:
Anne E. Bruder
Senior Architectural Historian**

May 2010

Abstract

Between 1948 and 1965, the Maryland State Roads Commission (SRC) built 3,452 miles of new highways and 557 bridges throughout the state in order to correct long standing engineering problems found on older roads. The SRC sought to create safe roads and bridges using design standards that would result in an efficient transportation system. In Maryland, the need for the new highways came about as a result of rapidly growing traffic volumes, new suburban development outside the state's cities and towns, and the need for military preparedness because of Maryland's common border with Washington, DC. These problems had existed before World War II, but by 1947 required resolution. Three public works programs, "The Five Year Plan," "The Twelve Year Program," and the "Go Roads Program" provided funding for the highway construction projects. Although the SRC was solely responsible for the design of the highways and bridges, and the development of the programs, political leadership by Governors William Preston Lane, Jr., Theodore R. McKeldin and J. Millard Tawes allowed the SRC to receive dedicated financing in order to complete construction of new highways and bridges. The new highways and bridge transformed Maryland's landscape and connected neighboring areas within the state with ease and speed. Since 1965, ongoing expansion of the highway system has altered many of its component parts.¹

In order to determine if any bridge built between 1948 and 1965 on the state primary or secondary highway system could be determined eligible for inclusion in the National Register of Historic Places (NRHP), the Maryland State Highway Administration (SHA) consulted State Roads Commission reports, plans, maps, databases, newspaper and journal articles, and local and state histories for Washington, DC, and Baltimore and Maryland, and other state and county agency highway planning reports at the SHA and Enoch Pratt Free libraries. Field visits to the bridges under consideration were made by SHA Architectural Historian Anne E. Bruder in 2009 and 2010. This is a comprehensive statewide study of the highways and bridges that were either newly constructed or altered during the study period (1948-1965).

Although most of Maryland's Interstate Highway System was constructed during this period, on March 10, 2005, the Federal Highway Administration and the Advisory Council on Historic Preservation exempted these highways and bridges from Section 106 consideration

¹ The database of bridges provided to the author by the SHA Office of Structures lists 557 bridges on SHA's highways. More bridges were actually constructed during this period, but some have been replaced and are not included in this number. 286 bridges are included to be evaluated in the current study. 152 bridges are Interstate bridges controlled by SHA which are not included in this study. 119 bridges are on other state agency's highways such as I-895 and I-95. Between 1948 and 1965, the Maryland Toll Authority (now the Maryland Transportation Authority or MdTA) was part of the Maryland State Roads Commission and the bridges on the Baltimore Harbor Tunnel Thruway (I-895) and the Kennedy Memorial Highway (I-95) were built under the SRC's highway construction programs. Because MdTA is a separate agency, SHA has not included those bridges in this historic context study, although it does discuss some of the highway construction projects because of their importance to the overall work completed between 1948 and 1965.

unless the structure or highway section has been identified as not meeting the exemption requirements. On the interstate roads controlled by SHA, only the Sideling Hill Exhibit Center and approximately one mile of I-68 on Sideling Hill in Washington County do not meet the exemption. SHA controls twelve interstate highways throughout the state, and there are presently 211 bridges on the system that have not been evaluated because they are not considered eligible for inclusion in the NRHP.

SHA identified 286 highway bridges to investigate as part of this study. SHA's records indicate that 1005 bridges built during the 1948-1965 period remain on county and state highways. However, unlike earlier studies, SHA has limited this study to the bridges on MD and US routes that form either the primary or secondary road systems in the state. It is our hope that other state and county agencies will make use of all the historic bridge studies when evaluating other highway bridges.

In discussions with the Project Review and Compliance Section of the Office of Preservation Services and the Office of Survey and Registration, Maryland Historical Trust (MHT) in March, 2010 to determine the most efficient way to document the bridges in this study, the agencies agreed to a simplified format. Since the bridges are one of several common types, SHA anticipates that those not already identified as eligible for inclusion in the National Register of Historic Places will be determined not eligible because of their ubiquitous nature. It was agreed by both agencies that Short-Form Determination of Eligibility describing each of the 286 bridges and providing a NRHP evaluation accompanied by a location map and a photograph of each bridge would provide sufficient information for MHT to comment with SHA's eligibility determinations. Additional information about the design of the individual bridge types is included in the historic context report in Appendix C. SHA seeks to streamline the review process while complying with Section 106 of the National Historic Preservation Act of 1966, as amended and its implementing regulations at 36 CFR Part 800 by identifying and evaluating bridges that were built between 1948 and 1965 on all Maryland state highways. This historic context study and the companion piece by URS, Corporation, *Phase II State Historic Bridge Context & Inventory of Modern Bridges, Survey Report and Assessments of Significance*, Vols. I, II, and III (2004) address SHA's efforts to identify, evaluate and assess eligibility of 286 bridges built between 1948 and 1965 on Maryland highways.

Table of Contents

Abstract	2
Research Design	6
Epigraph	10
Maryland's Highways 1938-1941	12
Federal Activities.....	14
State Struggles	14
Primary Bridge Program	15
Interregional Highways	16
World War II.....	17
Planning for Maryland's Post-War Highways 1942-1946	17
William Preston Lane, Jr. and the Five Year Plan, 1947-1952	19
Chesapeake Bay Bridge and Baltimore-Washington Expressway	20
The Chesapeake Bay Bridge.....	22
Theodore R. McKeldin's Twelve-Year Program, 1952-1959.....	23
Baltimore County Beltway.....	24
Baltimore Harbor Tunnel Thruway	26
Bypasses	26
Federal Highway Act of 1956.....	28
J. Millard Tawes and the "Go Roads" Program, 1959-1965	30
Capital Beltway	31
Northeast Expressway/I-95/Kennedy Memorial Highway.....	33
Bibliography.....	38
Appendix A: Results of Field Investigations.....	44
Appendix B: Bridge Types and National Register of Historic Places Eligibility Justification for 1948-1965 Bridges	45
Appendix C: Highway and Bridge Terms and Definitions	51
Appendix D: SHA Bridges Included in 1948-1965 Historic Highway Bridge Study	71
Appendix E: Resume.....	85

Table of Figures

Figure 1: US 40 over the Patapsco River, Baltimore County.....	13
Figure 2: US 40 over Middle Creek, Frederick County.....	13
Figure 3: Greenbelt Commuters, 1939.....	15
Figure 4: Improved US 40 after 1949 (left) and unimproved highway before 1949 (right)	20
Figure 5: MD 295 and MD 201 and US 50 Interchange, Prince George’s County	20
Figure 6: MD 168 over MD 295 Northbound, SHA Bridge No. 0201200	21
Figure 7: US 50 Westbound of US 301 Northbound, Queen Anne’s County, MD	23
Figure 8: Water Street over MD 295 Interchange.....	23
Figure 9: Old Westover-Crisfield Road, Somerset County, 1950	24
Figure 10: I-695 at Dulaney Valley Road looking west circa 1964	25
Figure 11: Baltimore Harbor Tunnel Entrance, 1958	26
Figure 12: Atomic Energy Commission Complex, Germantown, MD	27
Figure 13: US 50 looking west towards Baptist Street, Salisbury.....	28
Figure 14: Jones Falls Expressway looking south near North Avenue.....	29
Figure 15: I-83 looking north towards Shawan Road	31
Figure 16: Woodrow Wilson Memorial Bridge, I-495 over the Potomac.....	33
Figure 17: Governor Elbert N. Carvel of Delaware, President John Kennedy and Governor Millard Tawes of Maryland – I-95 Ribbon Cutting.....	34

Attachments

- Attachment 1: 1946/1947 Maryland State Road Map
- Attachment 2: 1965 Maryland State Road Map

Research Design

Like many other states throughout the United States following World War II, Maryland responded to the state's inadequate roads by building a new highway system between 1948 and 1965. By 1940, the Maryland State Roads Commission (SRC) had completed the SRC's original charter of creating a highway system that connected each county seat with Baltimore. However, driving to nearby towns without long detours could be difficult because of the lack of convenient connecting roads. The state also experienced a rapid increase in vehicles on the Maryland's highways as more people purchased vehicles to drive from one place to another. During this period, more Maryland citizens chose to move from cities and towns to suburban areas, which increased traffic on unprepared roads. The state highways' engineering and right-of-way problems also made them unsafe. In some cases these issues stemmed from the highway system's nineteenth century origins. Maryland's common border with the District of Columbia also required that the state's highways meet military preparedness requirements. In addition, the SRC required a dedicated funding source in order to build new highways because of the rising construction expenses.

Portions of Maryland's highway system began as colonial trails that became nineteenth century turnpikes, which the SRC in turn widened and paved as state highways between 1910 and 1940. Although the SRC had built some new highways, such as US 40 from Cecil County to Garrett County by 1940, many of the State's roads had limited improvement possibilities. From 1910 until 1940, the SRC repeatedly sought to address problems such as steep grades, sharp curves and lines of sight, as well as costly right-of-way purchases on the older, narrow roads throughout the state, but found making significant improvements difficult as traffic steadily increased.

Citizens purchasing new vehicles resulted in more automobiles on the state's roads. In Maryland, the number of vehicles registered in 1941 was 494,141, by 1948, the number increased to 569,082; in 1952 it increased again to 656,831 and by 1960 stood at 1,001,713. During holiday periods the average daily traffic could more than double on some highways as people drove through the state.² Although suburbanization outside the city limits was not new event by the post-World War II period, the large numbers of residential and commercial developments that were built after 1947 were unprecedented in Maryland's history. Roads that previously had low traffic volumes suddenly began to experience urban traffic levels as developers constructed new houses and shopping centers, and people began to use them.

Until 1941, Maryland did not have a limited access highway law, nor were there sufficient funds in the State's annual budget to adequately correct every unsafe highway problem. The limited access law would prohibit neighboring landowners from accessing any state highway directly from their properties, and the General Assembly passed it in 1941. Also

² Although there is no statistic to explain the traffic growth (e.g., car ownership doubled and therefore traffic also doubled every five years) Maryland's highways such as US 1 were frequently crowded during the holidays because of people driving through to places outside the state's borders. Other highways with heavy traffic counts included US 50 near Ocean City especially during the summer. In the twenty-first century, I-95 and US 50 remain heavily traveled during these same periods. See *Public Roads*, Vol. 23, No. 5 (July-August-September 1942) p. 101; U.S. Department of Commerce, *Statistical Abstract of the United States 1950, Motor-Vehicle Registration*, Washington, DC: US Government Printing Office (1950), page 489; *Highway Statistics 1948 State Motor-Vehicle Registrations - 1948*, Washington, DC: US Government Print Office (1950), page 26; *Highway Statistics 1952 State Motor-Vehicle Registrations - 1952*, Washington, DC: US Government Print Office (1952), page 26; *Highway Statistics 1960 State Motor-Vehicle Registrations - 1960*, Washington, DC: US Government Print Office (1962), page 51

in 1941, the SRC recommended a financing solution that would guarantee continued funding for road projects by increasing the gasoline taxes and vehicle registration fees and selling highway construction bonds. Although the SRC's recommendation received then-Governor Herbert O'Connor's approval, the start of World War II prevented any further action.

During the war, the SRC continued to plan for the new highway system. The construction of crossings of the Chesapeake Bay and Baltimore Harbor by bridges and a new highway between Baltimore and Washington, DC were the most pressing problems confronting the SRC in 1946. The election of William Preston Lane, Jr. as Governor that year provided the impetus to begin highway and bridge construction under the Governor's "Five Year Plan." The "Five Year Plan" called for increases in the gasoline sales tax, the vehicle registration fees and sale of \$100,000,000 of highway construction bonds in order to finance the Chesapeake Bay Bridge and Baltimore-Washington Parkway construction projects.

Lane served one term as Governor, but was not returned to office in part because citizens were unhappy with the sales tax increases. Theodore R. McKeldin won the election in 1951 and in 1952 came into office as Governor proposing the "Twelve Year Program" which called for construction of new highways and bridges in every county by 1965. McKeldin also increased the gasoline sales tax, vehicle registration fees and additional highway construction bonds were sold in order to continue financing new construction projects. Important projects included construction of the Harrisburg Expressway (I-83), and the Baltimore and Washington Beltways (I-695 and I-495 respectively). Passage of the Federal Highway Act in 1956 began the interstate highway construction program, and some of the highways the SRC planned to construct were built using federal funds, instead of state monies.

McKeldin served two terms, and in 1959, J. Millard Tawes became the Governor. He came from Crisfield on Maryland's Eastern Shore, and his highway construction program became known as "The Go Roads Program," which promised 100 miles of new highway construction every year until 1965. Many of the highways built during his tenure in office were on the Eastern Shore such as US 301, and US 50 Business in Salisbury but also included I-95 between Baltimore and the Delaware State Line, which was dedicated to President John F. Kennedy as the Kennedy Memorial Highway following his assassination a week after opening the new highway in 1963.

By 1965, the SRC built 3,452 miles of new highways and 557 bridges throughout the state. In order to construct the many new and dualized roads on the state system, the SRC incorporated standardization of highway and bridge elements to complete the design and construction jobs in a timely manner. Standardization of various components of a structure would reduce design and construction times because those items could be prefabricated off-site and sent directly to the construction site. The 485 metal girder bridges on the state's highway from the 1948-1965 period demonstrates how the SRC made practical use of standardization.

By the late 1940s, standardization was not a new innovation and did not result in a markedly different bridge design from those bridges built in the 1930s. The SRC began to use Standard Plans for its bridge designs in 1912 with plans for concrete slab and metal girder bridges. By the 1930s and early 1940s, the SRC did not rely on the earlier Standard Plans, but began to use standardized bridge elements to design and construct rolled and plate girder or reinforced concrete bridges for crossings that did not require a specialized solution. Bridge building is one of the most expensive undertakings for a transportation agency, and standardizing elements helps to control the costs of design and construction, as well as the amount of construction time. Through

the post-war period, SRC continued its earlier design practices using plate and rolled girders and reinforced concrete bridges to streamline and economize whenever possible.

Engineers and contractors also made use of the SRC's standard specifications for highway and bridge construction. These regularly published design guidelines did not specify a certain type of bridge, but provided information about how to construct a structure or road in a safe manner. The SRC was a founding member of the American Association of State Highway Officials (AASHO) in 1914, and remained active in the organization. Information developed by the various committees was promulgated in the AASHO's standards and specifications and could be adopted for practice by the SRC.³

Many of these roads and structures are now fifty years of age and will meet the National Register of Historic Places (NRHP) age requirement by 2015. In order to develop evaluation criteria, it is necessary to examine the events, persons and engineering and architectural achievements to determine if any bridge on the state system built during the 1948-1965 era would be eligible for inclusion in the NRHP.

SHA has examined local, state and national events, persons, and engineering and architectural achievements to identify significant highway construction in Maryland from 1948 through 1965 such as Governor William Preston Lane, Jr. and "The Five Year Plan" (1947), Governor Theodore R. McKeldin and "The Twelve Year Program" (1953) and Governor J. Millard Tawes and the "Go Roads Program," (1959). SHA also investigated pre-World War II information such as the SRC's Primary Bridge Program (1938), the national Defense and Interregional Highways Program (1938), and highway planning during World War II for the Baltimore-Washington Parkway (1944). SHA Cultural Resources Staff also conducted interviews with Mr. Earle S. Freedman, Director, SHA Office of Structures and Mr. Glenn Vaughan; Deputy Director, SHA Office of Structures, investigated primary sources such as highway and bridge plans on file at SHA, as well as secondary published sources such as Maryland State Roads Commission Biennial Reports, journal articles and books about highway construction history at the SHA and Enoch Pratt Free Libraries. Photographs from the SHA Photographic Archive, the Maryland Historical Society and the Library of Congress were also examined.

Of the 557 bridges remaining on SHA's highways from the study period, 485 are classified as stringer/metal beam or girder bridges or what SHA previously classified as rolled or plate metal girder bridges. The next largest bridge type is also a metal girder type, the girder and floorbeam system structures, of which there are seventeen. Thirteen rigid frame, eight slab and eight Tee-beam are the most common reinforced concrete types found in Maryland. The box beam or girder type can be either metal or concrete and there are twelve examples on state highways, including the aluminum girder bridge on Old MD 32 over the CSX, River Road and Patapsco River in Howard County. The preponderance of rolled or plate girder bridges on state highways speaks to the practical ways in which the SRC made use of standardization to complete the highway and bridge construction. A total of 286 bridges are on state primary and second highways and have been evaluated as part of the present study. The remaining bridges are on the Interstate system, and these have not been included in this study. While the SRC constructed many bridges and highways between 1948 and 1965, that is not an exceptional event. During this same period, other state Departments of Transportation such as Delaware, New Jersey, Virginia, Nebraska, Tennessee, Oregon and California were constructing similar bridges and highways in order to

³ The American Association of State Highway Officials (AASHO) is now the American Association of State Highway and Transportation Officials (AASHTO).

keep up with growing traffic on state highways. The steel beam and girder bridges and reinforced concrete bridges constructed during this period by the SRC became a common resource found on every highway in the state and in many other states as well.⁴

Although most of Maryland's Interstate Highway System was constructed during this period, on March 10, 2005, the Federal Highway Administration and the Advisory Council on Historic Preservation exempted these highways and bridges from Section 106 consideration unless the structure or highway section has been identified as not meeting the exemption requirements. On the interstates controlled by SHA, only the Sideling Hill Exhibit Center and approximately one mile of I-68 between MP 73.5 and MP 74.5 in Washington County do not meet the exemption. SHA controls twelve interstate highways throughout the state, and there are presently 210 bridges on the system that have not been evaluated because they are not considered eligible for inclusion in the NRHP. The remaining bridges are under the control of other state agencies and were not evaluated as part of this study.

SHA Architectural Historian Anne E. Bruder conducted field visits in 2009 and 2010 to view highways and bridges included in this study, reviewed photographs, developed written descriptions of structures, and consider the impact of the highway construction between 1948 and 1965 on the state's landscape.

Since 1998, SHA Architectural Historians have been evaluating state highway bridges for inclusion in the National Register of Historic Places (NRHP) as they reached the fifty years of age when these were included in SHA projects. Approximately forty-four bridges have been evaluated and thirty-eight have been determined not eligible, while six have been determined eligible. The Maryland Historical Trust (MHT) has concurred with these eligibility recommendations (see Bridge Types and National Register of Historic Places Eligibility below).

In 2003, SHA requested that the URS Corporation prepare an historic context report and evaluate twenty selected bridges for inclusion in the NRHP. That historic context report, *Phase II, State Historic Bridge Context & Inventory of Modern Bridges, Survey Report and Assessments of Significance*, Vols. I, II and III (URS Corporation, November 2004) should be read in conjunction with the current report and forms to gain a full understanding of the events, persons, and engineering and architecture achievements that occurred between 1948 and 1965 as the SRC built the new highway system. These historic context reports and determinations of eligibility should assist SHA Architectural Historians and consultants, as well as MHT, county and local review staff in determining the eligibility of post-World War II bridges in Maryland through 2015.

⁴ See for example *Delaware's Historic Bridges, Survey and Evaluation of Historic Bridges with Historic Contexts for Highways and Railroads*, Lichtenstein Consulting Engineers (2000), *Slab, Beam and Girder Bridges in Oregon, Historic Context Statement*, George S. Kramer (2004), and *The Third Ohio Historic Bridge Inventory, Evaluation, and Management Plan for Bridges Built 1951-1960 and the Development of Ohio's Interstate Highway System*, The Ohio Department of Transportation (2004) and *A Context for Common Historic Bridge Types, NCHRP Project 25-25, Task 15*, Parsons Brinckerhoff and Engineering and Industrial Heritage (2005). These are just a few examples of post-World War II historic context reports prepared by various state Departments of Transportation.

Epigraph

"*Tomorrow's Roads Today*" is the title of the State Roads Commission (SRC) of Maryland's 1959-1960 Biennial Report. There is no specific explanation in the report about what the title meant, but not all of the SRC's proposed projects included in the "Twelve Year Program" had been completed by 1959. The report notes that Maryland's citizens had become impatient with the SRC's progress, and the SRC sped up road construction in order to bring the completed highway system to a reality by 1965.⁵ The biennial reports through 1964 have similar peppy slogans for titles: *Building for the Future* (1961-1962), *Forging Ahead* (1962) and *Paving the Way* (1963-1964) with an anthropomorphic beaver unrolling a new road over an outline of the state's boundaries. In 1965 however, the report's title was changed to the matter-of-fact *A Highway Report*. Although all of the reports contain financial information to show how funds were used during each fiscal year in the reporting period, the format for the 1959-1964 reports changed to legal size and reports by the division chief of each office are one page long with photographs to show the progress being made.

Introduction

In 1947, as automobile traffic increased on Maryland's highways, the older, narrow road system, originally designed for horse and carriage became functionally obsolete. Although the SRC built several new highways by 1941, the majority of the state highway system consisted of improved Colonial and nineteenth century roads.⁶ After World War II, it became apparent to the SRC as well as to the Maryland Governors and General Assembly that many roads could no longer be improved because of limited right-of-way and the expense of engineering them for automobile traffic. Furthermore, Maryland experienced a population shift during the post-War period as more citizens moved from city to suburb, and roads that were lightly traveled experienced a sudden increase in traffic. As the Cold War started, Maryland's common border with Washington, DC and the presence of civilian and military Federal agencies in the state also stressed the need for military preparedness, including a reliable road system. The SRC believed that construction of a highway system on new right-of-way would be safer and more inexpensive since new designs would incorporate nationally accepted safety standards. By 1965, Maryland had an improved highway system with 3,452 miles of new roads and 557 bridges that the SRC believed were safe and adequate for most daily traffic volumes.

The SRC was also faced with securing funding for the construction of this new highway system. Federal aid through the Bureau of Public Roads was available on a 50-50 match basis, but some projects could be so expensive that one project could cost the SRC's entire annual construction budget. With multiple needs across the state, it was necessary to direct the money to critical projects. As early as 1941 the SRC had formulated a solution, recommending that the receipts from gas tax, car registration, and highway user fees be dedicated solely to highway construction. While Governor Herbert O'Connor and the General Assembly agreed with the proposal, the start of World War II prevented further action. Once the war ended in 1945, traffic increased at an unanticipated rate due to increase in automobile purchases, owners choosing to drive their cars rather than use public transportation, and suburbanization outside Maryland's cities and towns. By 1947, Governor William Preston Lane, Jr. and General Assembly were willing to approve increases to the gas tax, car registration and highway user fees, as well as

⁵ State Roads Commission of Maryland, *Tomorrow's Roads Today*, Twenty-Seventh Biennial Report, Baltimore, MD (1961), p. 3.

⁶ Maryland's first law requiring highway construction was passed by the Colonial Assembly in 1666.

issuing \$100,000,000 in highway construction bonds between 1948 and 1952 in order to finance new road and bridge construction.⁷ The financing scheme, which also included the fifty percent federal match, enabled the SRC to start construction of Maryland's expressway system.⁸ However, the two new highways, MD 295 and US 50, and the new Chesapeake Bay Bridge that were completed by 1952 were not sufficient to keep up with statewide traffic growth, nor was it the complete system envisioned by the SRC.

The SRC's second highway construction program, known as the Twelve-Year Program, was created to construct new and improve existing highways between 1954 and 1965 throughout Maryland. The program required additional increases in the state's gas tax of one-cent, car registration and highway user fees and new bonds for highways on new locations. Additional financial support came from the Federal Government in 1956 following the passage of the National System of Interstate and Defense Highways program, thereby funding ninety percent of highway construction projects.⁹ The SRC continued to design new highways, and in 1959 the construction program became the "Go Roads" program, promising to finish 100 miles of highway construction or reconstruction every year until 1965.

Between 1948 and 1965, the SRC constructed more than a dozen highways on new locations and improved more than fifty others, including building more than 557 bridges, ensuring Maryland's drivers had an adequate and safe road system. In order to complete the projects, the SRC incorporated its standards for design and construction and repeatedly used certain types of bridges to reduce design and construction times. By using these standards and timesaving methods, the SRC produced a highway system that met accepted national standards that was similar to many highway systems in other states. The SRC understood that traffic would increase annually and that the roads would need to be widened. Within ten years of completing construction of some highways, the SRC returned to widen the roads to six lanes due to increased traffic. For example, the typical four-lane highways that were built between 1948 and 1965 have been replaced by six-lane roads with concrete medians and paved shoulders, and noise walls to reduce the sound of traffic in nearby neighborhoods.¹⁰ The bridge decks have also been widened and no longer retain their mid-century concrete parapets with one or two strands of Alcoa aluminum or Bethlehem steel railings.

In addition to incorporating accepted design standards, each new highway had sufficient right-of-way limits to accommodate future traffic volumes, growing suburban developments and the need for military preparedness. The planned expansion of the highway system continued after 1965. Those developments have altered the highways and bridges built during the 1948-1965 period. Although isolated examples exist in many parts of the state, none alone or taken together retains sufficient integrity or cohesiveness to explain the significance of "The Five Year Plan," "The Twelve-Year Program," or "The Go Roads Program."

⁷ Herbert R. O'Connor was Maryland's Governor from 1939 to 1946, while William Preston Lane, Jr. served as Governor from 1947 to 1951.

⁸ The terms "expressway" and "freeway" are used by the SRC engineers to describe the type of highways they were designing and constructing in the post-War period. In Maryland the terms were synonymous and meant that the highways were initially four-lane roads, divided by a median with access by private property owners adjacent to the road and other drivers restricted to above-grade interchanges. The highways had a design speed of 70 m.p.h., although actual speed was restricted to 65 m.p.h.

⁹ In 2010, the federal funding limit is 80% while the state's share is 20%.

¹⁰ The SRC widened both I-495 (Capital Beltway) and I-695 (Baltimore Beltway) within ten years of completing each road because of increased traffic.

Evidence of eighteen years of road building by the SRC can be found in several ways. State highway maps provide a summary view on one sheet (Attachments 1 and 2), while project plans and the SRC's biennial reports from the study period provide information through drawings, photographs and writing.¹¹ The physical signs of the transformation of Maryland's landscape can also be found in the borrow pits and excess fill berms left by builders that remain near the highways. In some instances new highways divided farms, destroyed neighborhoods and forced property owners to relocate. Although the Governors and General Assembly, the SRC, and many citizens regarded the new highway construction as beneficial for residents and Maryland's economy, the public works projects altered Maryland's landscape.

Maryland's Highways 1938-1941

Maryland's interwar highway construction period culminated in 1941 following the construction of US 40 east ([Pulaski Highway] 1936-1939) and west ([Baltimore National Pike] 1934-1940) of Baltimore City, the Governor Harry W. Nice Bridge (US 301 over the Potomac) and the Susquehanna River Bridge (US 40 over the Susquehanna River), both completed in 1940. East of Baltimore, US 40 paralleled the original Philadelphia Road (MD 7) between the Baltimore City line and the Maryland-Delaware State line in Cecil County. It bypassed towns such as Havre de Grace and Elkton, but routed through the center of Aberdeen, near the Aberdeen Proving Grounds' entrance. In Baltimore City, the highway entered on Orleans Street, and as it crossed The Fallsway, it became a 1726-foot long viaduct crossing the North Central Railroad tracks, and Calvert and St. Paul streets before touching down. US 40 then split and westbound traffic was confined to Franklin Street, while eastbound traffic used Mulberry Street. The traffic used both streets until US 40 joined together again on Edmondson Avenue and became a rural arterial highway outside the City limits. Instead of building expressways in the 1930s, Baltimore City chose this method of routing traffic through the city, using one-way streets to create an arterial highway.¹² Although the road was termed an "arterial highway" it conformed to city streets with sidewalks and stoplights to regulate pedestrians and traffic.

West of Baltimore, US 40 or the National Pike, paralleled and sometimes used the original National Pike alignment from the Baltimore City line to the Maryland-Pennsylvania State line west of Keyser's Ridge in Garrett County. Like the eastern leg of the highway, it passed through Ellicott City, but bypassed Frederick. The SRC designed these highways using the current AASHO and SRC standards on file with the Bureau of Public Roads (BPR) at the Department of Commerce.¹³ Both highways, which were on new locations in the nine northern counties, had 20-foot wide lanes divided by large medians. Regardless, the SRC treated both segments of highway and median as one road, so the alignments were always parallel, and did not respond to variations in the landscape. On the eastern alignment, the bridges were designed as concrete encased metal girder or concrete beams with open railing parapets. On the western alignment, the SRC designed two open spandrel arch bridges – US 40 over the

¹¹ Full scale State Roads Commission Maryland State Highway Maps from 1946/1947 and 1965 are included here in Attachments 1 and 2.

¹² Maryland State Roads Commission, *Report of the State Roads Commission of Maryland, Operating Report for the years 1935-1936 and Financial Report for the fiscal year 1936*, Baltimore, MD: March 1937, page 3, see also *Frontispiece* that shows the completed Orleans Viaduct. The SRC appears to have assisted with the construction of the Orleans Viaduct. See also MIHP Form No. B-4542, SHA Bridge No. BC-1202, Orleans Viaduct, on file at Maryland Historical Trust, Crownsville, MD. A portion of the City's interstate system was constructed in the 1970s when a depressed interstate spur road, I-170, was built and cut through a nine-block section of West Baltimore. This is the expressway that was supposed to replace US 40 as part of the East-West Expressway.

¹³ See Footnote 3 above on page 9 for explanation of the AASHO acronym.



Figure 1: US 40 over the Patapsco River, Baltimore County
(Photograph by Melissa Blair, SHA, 2007)



Figure 2: US 40 over Middle Creek, Frederick County
(Photograph by John Hudacek, KCI, 2007)

Patapsco (SHA Bridge No. 0310900 [1936]) (Figure 1) and US 40 Alternate over the Conococheague (SHA Bridge No. 2101200 [1936]). Other closed arch and concrete rigid frame bridges with stone masonry facades and architectural treatments on wingwalls, buttresses and parapets built by the SRC, recalled the original stone arch bridges along the National Pike (Figure 2).

The SRC believed that the new highway locations would help prevent commercial and residential encroachments which made the older highways such as Baltimore-Washington Boulevard (US 1), Philadelphia Road (MD 7) and Old National Pike (MD 144) so dangerous. Many residential and commercial driveways opened directly on the highway thereby causing vehicles to slow or stop midlane. Often cars would cross several lanes of oncoming traffic to enter a property. Rear-end, T-bone and side swipe collisions were common events along highways such as US 1 between Baltimore and Washington.¹⁴

New legislation in 1941 addressed these issues when the General Assembly passed laws that limited access from all properties fronting a state highway and approved a new highway between Baltimore and Washington, DC. The success of the new Pennsylvania Turnpike encouraged the lawmakers to approve issuing bonds for a turnpike highway if the SRC deemed it necessary.¹⁵ Unfortunately, the start of World War II prevented any significant highway

¹⁴ Herbert Brean, "Dead End For The US Highway – The Horrible History Of One Road Explains Why The US Is Closer Than It Realizes To Being Immobilized By A Network That Is Obsolete, Wasteful And Murderous," *Life* Vol. 38 (May 30, 1955) pp. 104-118.

¹⁵ See Chapter 487 and Chapter 858 of the Acts of 1941, which define freeways, limited access and motorways available online from www.msa.md.gov/megafile/msa/speccol.

construction in Maryland. Single family homes and commercial structures continued to be built along US 40, and private property owners encroached upon the highway, especially near the Aberdeen Proving Ground and Edgewood Arsenal in Harford County. As a result, the multiple access points caused accidents similar to those on US 1 and contributed to traffic congestion.

Federal Activities

As an exercise to determine its readiness for war in 1936, the War Department identified roads across the county that would fulfill the national defense requirements of moving men and materials to any area by motor vehicle. During the interwar years, Maryland had both Army and Navy bases in Aberdeen, Frederick and Annapolis, as well as closer to Washington, DC in suburban Montgomery and Prince George's counties.¹⁶ Consequently, the military was particularly interested in improving the roads connecting Washington with Frederick, Baltimore and Annapolis. Although this new road system was politically supported for military readiness, it also greatly benefited the civilian population. The War Department planned to use existing highways, but proposed widening each for appropriate lane and shoulder widths and improving pavement strength in order to support fully loaded trucks. The SRC realized, however, that reusing the current system would perpetuate the sight distance and grade problems on these roads. Instead, the agency proposed creating new roads on parallel locations, which would allow traffic to continue on the old roads, while the new highways were under construction.¹⁷

Once President Franklin Delano Roosevelt completed his first term in office, he was able to turn his attention to defense and interregional highways -- roads that allowed traffic to move easily across the country. In 1938, the Bureau of Public Roads (BPR) prepared the first report, *Toll Roads and Free Roads*, for the President. The report contained information about construction of modern toll roads such as the Pennsylvania Turnpike, and whether such roads would be a successful way to finance a nationwide system of highways. As part of *Toll Roads*, the SRC provided its report, *Preliminary Report of the Maryland State-wide Highway Planning Survey*, which concluded that the state's highway were inadequate for modern traffic demands.

State Struggles

The SRC also provided a second report, *The Maryland Transportation Authority Annual Toll Facilities Report*, to the BPR for inclusion in *Toll Roads*.¹⁸ These reports made clear that the state's transportation agency sought ways to improve its statewide highway system, particularly a new highway connecting Baltimore with Washington, DC. The SRC, as well as the Maryland State Planning Commission, believed that US 1 had been widened and straightened as much as possible. Despite these efforts, the agencies could not keep up with the rapidly increasing traffic on the highway. In 1928, the average vehicles per day was 5,274, but by 1932, the average vehicles per day rose to 10,006 with a peak of over 27,000 automobiles and trucks during holiday travel periods. By 1935, the Maryland State Planning Commission concluded:

¹⁶ Aberdeen Proving Grounds, Aberdeen, Fort Detrick, Frederick, the (now closed) Hull Testing Facility across the Severn River from the Naval Academy in Annapolis, Naval Academy Dairy, Gambrills (also now closed), David Taylor Model Test Basin, Carderock, and the Naval Ordnance Laboratory, White Oak (now closed), both in Montgomery County.

¹⁷ State Roads Commission of Maryland, *Report of the State Roads Commission of Maryland, Operating Report for the Fiscal Years 1939-1940*, Baltimore, MD: March 1941, 5.

¹⁸ Greiner Engineering Company, Baltimore, MD 1941

Had this large increase in traffic that developed immediately upon completion [of the US 1 improvements in 1932] been visualized, it would have been apparent that an entire new road constructed on a modern alignment and grade and right-of-way to prevent encroachment would have been more economical.¹⁹

The traffic on US 1 was a combination of local traffic from Washington and Baltimore suburban communities like College Park and Elkridge, as well as vehicles traveling between the northeastern states and Washington, DC. These long distance motorists also found Baltimore



Figure 3: Greenbelt Commuters, 1939²¹, Photo courtesy of the Library of Congress

to be a choke point because of the need to negotiate the city's streets. In new towns like Greenbelt, workers carpoled to Washington, but such activities did little to reduce the growing local suburban traffic because there was limited public transportation in these areas in the 1930s (Figure 3). As the agencies discussed a new highway to the south, the crossings of three rivers and the Chesapeake Bay also demanded the SRC's attention.²⁰

Primary Bridge Program

In 1938, the SRC commissioned Greiner Engineering to develop recommendations for highway and bridge construction in Maryland. By October of that year, Greiner provided the SRC with a report, which identified the need for four large bridges crossing the Potomac, the Susquehanna and the Patapsco Rivers and the Chesapeake Bay. The state's General Assembly supported the bridge building program and passed legislation that allowed the SRC to issue transportation bonds to finance the bridge construction. At the same time, the agency received a federal Public Works Administration (PWA) grant which helped to pay for one bridge. The combination of the PWA grant and the successful bond issue enabled the SRC to construct the Susquehanna River Bridge and the Governor Harry W. Nice by August and December 1940, respectively. The Susquehanna River Bridge stands between Havre de Grace and Perryville, northeast of Baltimore, while the Governor Harry W. Nice Bridge over the Potomac River between Morgantown, Charles County and Dahlgren, Virginia, carried US 301 across the river north of Richmond. Each bridge was more than a mile long and composed of steel trusses with a suspension span on the Nice Bridge, rather than steel beams and concrete. These designs

¹⁹ Maryland State Planning Commission, *Ten Year Highway Construction Program for Maryland*, Baltimore (March 1935), p. 10

²⁰ Maryland State Roads Commission, *Preliminary Report of the Maryland State-wide Highway Planning Survey*, Baltimore, MD, in cooperation with the United States Department of Agriculture, Bureau of Public Roads, 1938

²¹ Library of Congress, Prints & Photographs Division, FSA/OWI Collection, reproduction number LC-USW3-003675-E

helped to reduce the construction costs and time to complete the projects.²² Both bridges opened as toll facilities and were successful in attracting motorists who paid the tolls, which in turn paid off the bonds and provided revenue for other highway projects. The SRC sought additional ways to increase revenues as a way to ensure money for additional road construction. Despite the fact that a portion of the state's gas tax was dedicated to highway building, the General Assembly frequently used the monies for other purposes to close the state's budget. The two new bridges and the new US 40 highways further highlighted the need to make improvements in other highways.

As the SRC finalized the bridges' construction in September 1940, a new study anticipating the state's highway needs between 1941 and 1960 was completed by the agency. *Maryland Highway Needs, 1941-1960, A Report of the State-wide Highway Planning Survey* concluded that a dedicated source of funding for future road construction was necessary in order to meet the growing traffic demands throughout the state.²³ As traffic numbers showed, the difficult economic conditions in the late 1930s did not reduce the number of cars and trucks on the state's highways each year. On US 1 between 1928 and 1932, traffic had increased more than fifty percent in four years or more than ten percent per year. In other areas of the state, traffic also continued to increase. On the Eastern Shore, Ocean City attracted more visitors each year, which increased traffic on the highway to the resort (now US 50, previously MD 213). Boosters of the Ocean Highway, US 13, publicized the road as a quick route from New York City to Florida because it avoided the traffic in Baltimore and Washington, DC, as well as Richmond, Virginia. Although the Governor and General Assembly supported the dedicated funding and new roads, other issues including the start of World War II prevented the SRC from receiving adequate funding to build a new highway system.

Interregional Highways

The interregional highway system question again came to the forefront in 1941. Roosevelt appointed the National Interregional Highway Commission to further develop the 1938 interregional plan and address nationwide traffic congestion. Roosevelt and other Federal and State officials also expected that once the war ended, unemployment rates would rise. They saw highway construction as a way to create jobs for returning soldiers. The SRC used Baltimore's proximity to Washington, DC to study some of the traffic problems that would be a concern in any new national highway plan. Although the SRC made plans for civilian uses, America's entry into World War II highlighted the defense aspects of the plan. Many Marylanders hoped for a better road than US 1 between Baltimore and Washington. At the time Federal officials were more concerned about war preparations, as the BPR's Administrator Thomas H. MacDonald noted during a March 13, 1941 interview *The Baltimore Evening Sun*, Maryland needed new roads for its defense industry and military access more than a new expressway between Baltimore and Washington.²⁴

²² John E. Greiner, Consulting Engineers, *Maryland's Primary Bridge Program*, Maryland Department, Enoch Pratt Free Library, 1938.

²³ State Roads Commission of Maryland, *Maryland Highway Needs, 1941-1960, A Report of the State-wide Highway Planning Survey*, Baltimore, MD (1940);

²⁴ *The Baltimore Evening Sun*, "Baltimore Itself Is Bottleneck in Highway Plans, Say Experts," March 13, 1941, Maryland Department, Enoch Pratt Free Library

World War II

Ultimately, World War II interfered with the SRC's construction of the new Baltimore-Washington expressway or the new Chesapeake Bay Bridge that Greiner proposed. Further complicating the issue was the disagreement between the state and the City of Baltimore about whether the highway would cross Baltimore's active harbor through a tunnel or over a bridge. The one bridge that crossed the harbor was the 1916 Hanover Street Bridge, a double leaf bascule bridge. Movable bridges stopped vehicular traffic when a ship passed through the bridge, which was not an efficient way to keep traffic moving in Baltimore. During the War the SRC continued discussions and planning for the bay bridge and a new highway that would cross the harbor and connect Baltimore with Washington. Although the highways which the SRC had constructed prior to the war would not have kept up with peacetime traffic, the war caused a reduction in most traffic volumes in Maryland, because of the war rationing. As a result, the highways were sufficient for war related traffic.²⁵

Planning for Maryland's Post-War Highways 1942-1946

As the war continued, federal and state funding for highway construction became unavailable. Likewise, more and more of the engineers and maintenance crews were called into military service. The SRC only constructed highway projects that improved transportation to military bases or war related industries during the war. However, the engineers who remained at the SRC and Greiner Engineers continued to make plans for both the Chesapeake Bay Bridge and the Baltimore-Washington highway for possible post-War construction. There was concern by federal and state agencies that with the end of the war, unemployment would return to Depression-era levels, and highway construction was an employment option for returning veterans.

The traffic impacts to Baltimore continued to influence the planning for the locations of the new Baltimore-Washington Expressway and Chesapeake Bay Bridge. Greiner's 1938 bridge study had recommended two possible locations for the bay bridge, one at the northern end of the bay between Miller's Island and Colchester, Kent County, and the other between Sandy Point, Anne Arundel County and Kent Island, Queen Anne's County. The U.S. War Department and the commander of the Aberdeen Proving Ground opposed the northern alignment because of its proximity to the munitions test areas. Furthermore, the northern crossing paralleled US 40 so it did not alter the traffic impacts to Baltimore since traffic would still enter the City. The Sandy Point-Kent Island alignment became the preferred location because it would carry more traffic, serve more people because of the central location between the Eastern and Western shores, and avoid the traffic problems in Baltimore.²⁶

This central shore location was the site of the Matapeake Ferry which traveled between Sandy Point and Kent Island in southern Queen Anne's County.²⁷ Greiner's study concluded that

²⁵ The only new or improved highways built in Maryland during the war were roads that connected military bases or war-related industries such as the Suitland Parkway between Andrews Air Force Base and Washington, DC, MD 150 between the Martin Air Plane Factory and Baltimore, and improvements to MD 237 near the Patuxent Navel Air Station in St. Mary's County. All of the work was approved by the Army and Navy Departments and funds were released by the War Production Board in order to acquire restricted materials and labor to do the construction. See, *Report of the State Roads Commission of Maryland, Operating Report for the Fiscal Years 1943-1944*, Baltimore, MD: 1945 (page 1).

²⁶ Greiner, Primary Bridge, 1938

²⁷ Crossing the Chesapeake Bay by ferry required two ferry rides: one between Sandy Point and Matapeake on Kent Island and a second between Romancoke on Kent Island and Claiborne in Talbot County near St. Michaels.

while the four Matapeake ferry boats carried 360 vehicles per hour, a new two lane bridge would handle 1,500 cars an hour. By building the bridge in the mid-Bay area, the traffic from southern Maryland and points south could be diverted from around both Washington and Baltimore and travel to the Maryland-Delaware border if they were going north. At the same time, drivers from the Eastern Shore would avoid Baltimore's congestion if they traveled south or west. By 1940, the SRC's planning had proceeded and it received the Rivers and Harbors Act of 1899 Section 10 permits for building the bay crossing from the US Army Corps of Engineers.²⁸ However, the war again delayed the start of construction, and the SRC programmed construction in 1949.

At the same time, the SRC continued design planning for the new expressway between Baltimore and Washington. In 1942, Greiner Engineering began the reconnaissance and soil surveys to direct the final highway location. By 1944, Greiner provided the SRC with a final proposal for constructing a new road between the two cities. The study, *Washington-Baltimore Freeway*, recommended that the SRC construct a road between Jessup's Road fifteen miles south of Baltimore, and Franklin Street, which was a leg of US 1 through the City.²⁹ The highway would be located west of US 1 and require an extensive highway network to connect to the City's streets. Greiner's project also provided a separate crossing of Baltimore's Harbor that would connect with US 40 on the east side of the City. In all, Greiner proposed five different alignments. Each crossed streets at the south end of the City, and also required property from St. Agnes Hospital and the Industrial School. Furthermore, it proved to be more expensive than the State, federal government or City anticipated because of the right-of-way costs. Ultimately, these alignments highlighted the difficulties of bringing a high-speed highway into the city where the street grid was already established.

Although the SRC had completed its studies, Baltimore had not agreed with any of the state's plans. In May 1945, Nathan L. Smith, Baltimore City's Chief Engineer, sent Mayor Theodore R. McKeldin his recommendations for post-war highway needs in and around the City. At that time, Baltimore had decided to relocate its airport to Friendship, which was thirteen miles south of the city line. Smith concluded that if the new highway passed closer to the proposed airport it would shorten the travel time between the City and the airport. Smith's recommendation highlighted a new direction for road construction. Early in the twentieth century, the SRC planned roads to connect one town with another. Since traffic congestion slowed travel, engineers sought ways to make easy connections that would shorten travel time by avoiding town streets. As a result, Smith recommended that the expressway could enter Baltimore via Russell Street. The Mayor postponed his decision until 1947, when it became apparent that the agencies could only afford to build one highway. The decision to use Russell Street as the connection to the Baltimore-Washington Parkway brought the highway into the City without crossing the harbor; however, the connection did not mitigate traffic congestion in Baltimore's Central Business District (CBD).³⁰ Russell Street became a connecting road but still retained its city street attributes of sidewalks and stoplights that characterize the area, much like US 40 on Franklin and Mulberry streets. Before reaching the City's CBD, portions of the Parkway were also placed on overpasses

²⁸ Rivers and Harbors Appropriation Act of 1899 (33 USC §403) requires Congressional approval and a Section 10 permit issued by the U.S. Army Corps of Engineers for any bridge or tunnel crossing navigable waters in the United States.

²⁹ John E. Greiner, Consulting Engineers, *Report Submitted to State Road Commission of Maryland, Washington-Baltimore Freeway from Jessup's Road, Including Highway Approaches to the Patapsco River Bridge and Franklin Street Connection*, March 1944, Maryland Department, Enoch Pratt Free Library.

³⁰ Nathan L. Smith, *Analysis of Traffic Conditions and Present and Post-War Highway Requirements*, Chief Engineer, Department of Public Works, to Theodore R. McKeldin, Mayor of Baltimore (May 21, 1945), Maryland Department, Enoch Pratt Free Library.

since the highway crossed the Pennsylvania Railroad tracks and roads that could not be elevated in an interchange.

Construction of the Baltimore-Washington Parkway also provided an opportunity for the BPR to work with the SRC and Baltimore City. The southern portion of the route of the Baltimore-Washington Parkway passed through federal lands at Greenbelt, the Beltsville Agricultural Research Center, and Fort Meade but the government still required some additional right-of-way. Since these lands were east of US 1, the federal section of the highway would align with the recommended alignment in Baltimore City. However, the BPR assigned the highway to the National Park Service to manage the highway and that dictated the design of the eighteen-mile section of highway as a parkway, rather than an expressway. Ownership of highways would remain in debate by the federal and state governments for the next twelve years. Although the SRC anticipated starting \$45,000,000 in construction projects once the war ended, until the peace treaties were signed, materials and manpower remained dedicated to the war effort through 1945.

William Preston Lane, Jr. and the Five Year Plan, 1947-1952

William Preston Lane, Jr., a lawyer and businessman from Hagerstown, was elected governor in 1946 and began his term in January 1947. During the 1946 campaign, he frequently highlighted the need for improved highways throughout the state.³¹ In his January 1947 inauguration speech, Lane talked about the necessity for new highways and bridges for Maryland's success in the post-War period. On March 6, 1947, the Governor again raised the issue to the General Assembly. His program, which he called "The Five Year Program," proposed that the financing of necessary bridges and highways would be created by the State selling \$100,000,000 in bonds, which in turn would be repaid through tolls on certain highways and bridges. The governor also requested a one-cent increase in the state's sales and gas taxes, and an increase in automobile and truck registration fees. All of these monies were specifically designated for the SRC's use for highway and bridge construction. Lane's Five Year Program called for construction of a "modern" highway system. It would be based on a "master plan for an integrated arterial state highway system." In his speech, the Governor also called for a "toll-free expressway system" for the intra-state traffic.³² The General Assembly agreed with his proposals and Article 89B of the Annotated Code of Maryland, "Express Highways Act," was amended and passed in 1947.³³

³¹ "Highway Fund Diversion Hit," *The Washington Post*, June 5, 1946, p. 8.

³² Governor William Preston Lane, "A Message to the General Assembly by Governor William Preston Lane, Jr. on the State Highway System." March 6, 1947

³³ William Preston Lane, "A Message to the General Assembly by Governor William Preston Lane, Jr. on the State Highway System," March 6, 1947, Maryland Department, Enoch Pratt Free Library. See also, Expressway Act of 1947, Vol. 411, Page 1383 of the On-line Archives at www.msa.md.gov/megafile/msa/speccol.

Chesapeake Bay Bridge and Baltimore-Washington Expressway



Figure 4: Improved US 40 after 1949 (left) and unimproved highway before 1949 (right)³⁴ (Source SHA Photo Archive)

1948 on the highway. Starting at the City line, the state began grading the road to the south. The highway became the first new road in Maryland to be constructed according to the 1941 Interregional Highways report. The road was not two parallel roads with a median and one grade such as the 1930s' US 40. Rather it was two independent roads on similar alignments, but if the terrain changed, each could also follow the changing topography. Most importantly, there were interchanges that allowed traffic to move at speed from one highway to another with extended merge lanes that eased vehicles onto the highway. The interchanges allowed for connections



Figure 5: MD 295 and MD 201 and US 50 Interchange, Prince George's County. One "paperclip ramp" is in the northwest corner of the interchange.³⁶

Post-war traffic volumes picked up as soldiers returned from the war and the economy turned from war production to peace time initiatives (Figure 4). In 1941, 429,937 cars and buses were registered in Maryland. By 1948, the number of vehicles on state roads rose to 569,082.³⁵ The SRC and the Maryland government were aware of the traffic rate's rapid rise because the state's roads were overcrowded and accidents occurred frequently. Passage of the 1947 Expressway Act allowed the SRC to begin the two projects that would complete portions of the Primary Bridge Program: the Chesapeake Bay Bridge and the Baltimore-Washington Expressway. The SRC awarded Greiner Engineers the contract and work began in

between nine cross roads at Bladensburg, Annapolis, Riverdale, Greenbelt, Powder Mill, Laurel-Fort Meade, Savage, Jessup's, Dorsey, Friendship Airport and New Nursery. The design of each interchange matched traffic volumes, and included cloverleaf, diamond and one "paperclip" design (Figure 5).

Also, landowners would not be allowed to have access to the highway except from the interchanges, thereby eliminating dangerous access points that had plagued Maryland's earlier highways. In fact, landowners whose properties bordered the highway were required to realign their entrances to side roads. The SRC completed

the Baltimore-Washington Expressway in 1951 between the Baltimore City line and Jessup's Road (MD 175), and opened the road to traffic in 1952. The SRC designed this section of the

³⁴ Source SHA Photo Archive.

³⁵ Statistics from "State Motor Vehicle Registrations – 1941," *Public Roads*, Vol. 23, No. 5 (July-August-September 1942) p. 101; and "State Motor Vehicle Registrations – 1948," *Highway Statistics 1948*, U.S. Department of Commerce Bureau of Public Roads, Washington, DC: US Government Printing Office, 1950, page 26.

³⁶ Source SHA Photo Archive.

highway as an expressway, with three lanes of traffic between the City line and I-695 southbound, and from I-195 to the City line northbound.

The BPR and National Park Service (NPS) completed the eighteen mile federal portion designed as a parkway in 1954. Unlike the northern expressway segment, the federal portion between MD 175 (Jessup's Road) and I-495 had two lanes northbound and southbound, separated by a large median. The median was landscaped with both natural and planned elements, and the park surrounded the parkway. The NPS designed twenty-eight bridges and overpasses incorporating designs for parkway bridges with stone masonry facing over concrete rigid frame or steel girder and beam structures. Underpasses tended to be built with minimal decoration, while overpasses, which were more visible to motorists, were faced with granite.³⁷

The seventeen bridges that the SRC built between the Baltimore City line and MD 175 during the Five Year Program were either stringer/multi-beam girder or concrete rigid frame structures. The Baltimore-Washington Parkway crossed roads as well as rivers and streams, so the steel beam bridges could be constructed with minimal disruption to the cross roads (Figure 6).



Figure 6: MD 168 over MD 295 Northbound, SHA Bridge No. 0201200 constructed in 1949 (photo by Anne Bruder, SHA, 2009)

These bridges were not new designs for the SRC. The agency began using standardized plans in 1912 for concrete slab and beam bridges.³⁸ In response to increasing traffic over these structures, the SRC periodically refined the bridge designs by strengthening girders and increasing the width of the structures. By the 1930s, the metal girder had become the SRC's regularly chosen standard design, although the agency no longer depended on a published standard plan. The use of metal girder bridges continued in the early 1940s.

By the late 1940s, the SRC needed to build roads efficiently and quickly because of the rapidly increasing traffic. In the three years following the war's end, more than 74,000 cars

were added to those that had been on the highways in 1941. Before the war, the SRC had struggled to keep up with growing traffic on the state's highways. After the war, it was a necessity. In addition to growing car ownership, many people chose to live outside the Washington and Baltimore city limits in new suburban developments. Traffic in new areas outside the cities was an unanticipated problem that increased highway congestion and accident rates. A final issue compounding the SRC's traffic problems was Maryland's common border with Washington, DC. The start of the Cold War with the threat of nuclear war required the SRC to improve the road system for better military readiness and possible civilian evacuations.

³⁷ Melissa F. Blair, DOE AN-0101, SHA Bridge No. 0201900, Ridge Road over MD 295, 11-15-2005. The Baltimore-Washington Parkway controlled by the NPS is listed in the National Register of Historic Places. A number of the bridges on this portion of the highway have been widened, although the original designs were maintained and each was determined to continue to contribute to the Parkway.

³⁸ *Report of the State Roads Commission of Maryland*, Baltimore, MD: 1916, p. 56

When the Baltimore-Washington Parkway opened on October 23, 1954, *The Baltimore Sun* reported that travel times between Baltimore and Washington had been reduced to forty-five minutes compared to the over one-hour commute on US 1.³⁹ The ease and high speed of traveling between two distant places on a wide and stoplight-free highway became the hallmark of Maryland's post-war highway system.

During the Five Year Program, in addition to the construction of the Baltimore-Washington Parkway and the Chesapeake Bay Bridge, the SRC also worked on a number of other state highways, widening them and building new bridges for the wider roads. With the large number of projects to complete, the agency used standardization for every aspect of road construction because it decreased the design and construction periods. One aspect of the standardization was in the SRC's incorporation of the AASHO guidelines and standards for highway and bridge design into the SRC's own published standards. The AASHO and SRC guidance did not specify a particular design, but provided information about how to design safe and adequate roads and bridges and a dependable product.

The Chesapeake Bay Bridge

In 1949, as construction of the Baltimore-Washington Parkway continued, the SRC also began building the Chesapeake Bay Bridge, including the US 50 approach roads outside of Annapolis and on the eastern shore towards Queenstown. In particular, the SRC confronted a poor crossing between Maryland's Eastern and Western shores. In addition to the distance of four miles, the bridge crossed over the main shipping channel leading to the Baltimore ports. Although delayed by World War II, the Section 10 permit that had been issued in 1940 by the U.S. Army Corps of Engineers was still effective and work began in 1949.⁴⁰

The Chesapeake Bay Bridge is a multi-span structure with concrete beam approaches, Wichert and simple deck trusses and two types of cantilever trusses, which form a suspension bridge at the main crossing between the two towers.⁴¹ Originally the bridge had a 24-foot roadway width with two 18 inch emergency footways. One lane of vehicles crossed the bridge in each direction.⁴² When the first bridge was completed in 1952, it was notable as the largest suspension bridge in the world and for permanently connecting Maryland's Eastern and Western shores. More importantly, it was the first toll facility constructed under Governor Lane's Five-Year Program using money generated from the highway bonds. Unlike the Baltimore-Washington Expressway, the Chesapeake Bay Bridge was planned as a revenue generating project. The highway bonds sold slowly but steadily and by 1953, all \$100,000,000 were expended or committed for specific projects.

In addition to the bridge, the SRC also constructed the approach roads on US 50 between Annapolis and Queenstown, along with a new bascule span bridge between Kent Island and the Eastern Shore mainland (Figure 7).

³⁹ *The Baltimore Sun*, "45 Minutes to Washington," October 24, 1954, Maryland Department, Enoch Pratt Free Library Vertical Files.

⁴⁰ Section 10 of the Harbors and Rivers Act of 1899 permits are issued by the US Army Corps of Engineers.

⁴¹ Also known as the William Preston Lane, Jr. Memorial Bridge in honor of the Governor's patronage 1947-1952. The Maryland Toll Authority (now Maryland Transportation Authority or MdTA) added three lanes to the crossing when the parallel span opened in 1972.

⁴² The Chesapeake Bay Bridge was widened by removing safety sidewalks and reducing the width of the shoulders.



Figure 7: US 50 Westbound of US 301 Northbound, Queen Anne's County, MD (Source: SHA Photo Archive)

Governor Lane was defeated in his reelection bid in 1950 because of the voters' dissatisfaction with his increased sales taxes. However, under his Five Year Program, the SRC had constructed or reconstructed 757 miles of highway, and started the planning and construction of the expressway system and the Chesapeake Bay Bridge with its approach roads in Anne Arundel and Queen Anne's counties. The SRC completed the Bay Bridge in 1952, and the Baltimore-Washington Parkway opened to traffic in 1954 between Baltimore and Washington, DC.

Lane lost the 1950 election to Theodore R. McKeldin of Baltimore. Although the defeat meant an end to Lane's Five Year Program, McKeldin understood Maryland's need for highways, and would approve the construction of the Washington and Baltimore Beltways or Circumferential Highways, the Baltimore Harbor Tunnel, and the start of the interstate construction specifically associated with President Dwight Eisenhower's 1956 program.

Theodore R. McKeldin's Twelve-Year Program, 1952-1959

Theodore Roosevelt McKeldin understood the need for better highways due to his tenure as Baltimore's Mayor between 1943 and 1947. As mayor he had received a 1944 proposal from New York City Planning Director and consultant Robert Moses to demolish blighted areas near the Central Business District (CBD) in order to construct a new expressway through the City. The area that Moses proposed for the new expressway was on the north side of the CBD in Baltimore City near the Mount Vernon District. The proposal would displace a number of residents, including business elites. The Mount Vernon residents opposed the plan, and it was dropped from consideration.⁴³



Figure 8: Water Street over MD 295 Interchange (Source: SHA Photo Archive)

As Mayor, McKeldin also made the final decision on the location for the Baltimore-Washington Parkway entrance to the City. The City Public Works Department extended Russell Street south to meet the Baltimore-Washington Parkway at the City-Baltimore County boundary. As with other portions of the highway, at-grade intersections were made into interchanges and while other portions were made into bridges avoid railroads (Figure 8). During this highway

⁴³ Robert Moses to Mayor and City Council of Baltimore, "Study of Arterial Roads in Baltimore," October 9, 1944, on file Maryland Department, Enoch Pratt Free Library, Baltimore, MD

initiative McKeldin ran against Governor William Lane and won the 1951 election for Governor. Subsequently, McKeldin's concern for highways now included the entire state of Maryland.

As McKeldin began his first term in 1951, the SRC completed a new report, *Proposed 12-Year Program for Road Construction and Reconstruction, 1954-1965*, and submitted it to the Governor for his consideration.⁴⁴ The SRC's report stated that the funds from Lane's Five Year Program would be spent or committed by 1953, and that funds to construct and reconstruct additional highways would be necessary. The report noted that while Maryland had 4,736 miles of highway, it was an old system with many rehabilitated roads. The older roads had varying widths because the SRC had not been able to bring all of its highways to a single approved standard before World War II (Figure 9). The Twelve Year Program identified roads which would be built



Figure 9: Old Westover-Crisfield Road, Somerset County, 1950⁴⁵

or improved during three four-year intervals: 1954-1957, 1958-1961 and 1962-1965. The SRC focused first on the Primary Highway system, which included all of the highways that connected county seats with Baltimore. MD 140 is an example of a highway that connected outlying towns such as Westminster in Carroll County to Baltimore that was upgraded by relocating the road to bypass the small towns. The work started in 1949 and continued for several years.

Although there were major highway projects planned by the SRC, the agency understood other roads also required attention, and therefore they required a "program of fixed priorities" in order to know how to best meet their proposed

deadline of twelve years. The SRC also had concerns about road construction; they wanted to be sure that any new road would attract and distribute traffic in an effective manner.⁴⁶ In order to accomplish the Twelve-Year Program's goals the General Assembly would need to approve new sales and gas taxes, increase registration fees, and issue new bonds.

Baltimore County Beltway

The public supported increased costs of highway construction due to the poor condition of the highways statewide. One problem that interested Governor McKeldin was the traffic congestion caused by citizens using Baltimore's inner city roads as a thoroughfare for areas outside of the city limits. While he considered the SRC's Twelve Year Program, two local planning agencies, the Baltimore County Office of Planning and the Maryland-National Capital

⁴⁴ State Roads Commission of Maryland, *Proposed 12-Year Program for Road Construction and Reconstruction, 1954-1965*, October 26, 1952, p. 1

⁴⁵ Source: SHA Photo Archive; (also see Figure 6 above)

⁴⁶ *Ibid.*, p. 12 and p. 24

Park and Planning Commission in Prince George's and Montgomery counties, proposed that the counties construct circumferential highways around Baltimore and Washington, DC. Both agencies believed that traffic congestion could be relieved on all the counties' radial roads by providing a single highway that connected those roads. Some of the roads were former turnpikes that connected Baltimore with Washington, Philadelphia, Harrisburg, and Frederick. Other highways such as Georgia and New Hampshire avenues were extensions of the Washington, DC city streets. The roads had been extended beyond the City's boundary, and commercial and residential development occurred along these roads in the county where land was less expensive.⁴⁷

During the late eighteenth and early nineteenth century, nine private turnpikes were chartered between Baltimore and Frederick, Reisterstown, York, Pennsylvania, Bel Air (and Philadelphia), Havre de Grace, and Washington, DC (Bladensburg and Georgetown). Turnpike towns like Pikeville, Towson, Lutherville, and Parkville ringed the city, but were not connected to one another, or were inefficiently connected. Getting from one town to another required travel through the City and back out on another road. Following the SRC's creation in 1908, the agency gradually took over the roads, converting them to state highways. By the late 1940s, as the first wave of suburban development occurred north of Baltimore, travel between the towns became increasingly difficult.

Baltimore County planners developed the route of the new beltway and Governor McKeldin inaugurated construction by turning the first shovel of dirt in 1954. Initially, Baltimore County planned the road as a connection to the Baltimore-Harrisburg Expressway from Towson and Pikesville. The SRC, however, took over the project and concluded that linking seven

communities together by one highway was a practical solution to the nineteenth century radial road problem, so the road was extended both east and west in the late 1950s.⁴⁸ The road was completed in July 1962 as a four lane, divided highway with interchanges at the radial roads. As with other highways from this period, the Baltimore Beltway construction used many of the standardized elements that the SRC used on other highways – most of the bridges were metal girder or stringer/multi-beam or girder examples.⁴⁹ The SRC engineers quickly learned that their traffic estimates were low. During the late 1940s, the engineers believed that traffic grew at a rate of five percent a year; however, once the Baltimore Beltway was completed, its traffic actually increased at a rate of ten percent a year.⁵⁰



4 Dulaney Valley Rd

Figure 10: I-695 at Dulaney Valley Road looking west circa 1964.⁵¹

⁴⁷ Planners in both cities envisioned a ring of beltways within the city near the Central Business District, a middle ring road and an outer ring road. None of the in-town beltways were built, while both I-495 and I-695 are the middle distance beltways, and the Intercounty Connector will have an alignment that is near to the proposed outer beltway.

⁴⁸ Neal A. Brooks and Eric R. Rockel, *A History of Baltimore County*, Towson, MD: Friends of Towson Library, Inc. (1979) p. 373; State Roads Commission of Maryland, *forging Ahead, an Interim Report 1960-1962*, n.p.

⁴⁹ The connection across the mouth of the Patapsco River, Key Bridge, a large through truss bridge, was completed in 1977.

⁵⁰ SRC, 12-Year Program, p. 4.

⁵¹ Source: SHA Photo Archive

Historic photographs of the Beltway's construction shows established residential development in Baltimore County by the 1960s (Figure 10). Although Brooks and Rockel state that I-695's construction required few relocations, the highway bisected neighborhoods, thereby dividing communities.⁵²

Baltimore Harbor Tunnel Thruway



Figure 11: Baltimore Harbor Tunnel Entrance, 1958

As the SRC constructed the Baltimore Beltway, a new toll road was programmed for design and construction, the Harbor Tunnel Thruway (Figure 11). The seventeen mile long highway and four lane tunnel in two tubes, was proposed in 1954, construction began in 1955, and was completed in November 1957. At the time of its construction, “the tunnel was the longest twin-tube trench-type tunnel in the world. The prefabricated tunnel sections were sunk in an open trench.”⁵³ The highway portion has 55 bridges, which are metal girder or stringer/multi-beam or girder. All

were constructed in one building campaign in 1957, along with one K-Truss Bridge over the B&O Railroad. The Harbor Tunnel Thruway connected to the Baltimore-Washington Parkway and US 1 on the southwest side of the City, and on the east side connected with US 40, providing a bypass of downtown Baltimore for travelers going north or south of the city.

Bypasses

As part of the Twelve-Year Program, the SRC studied various towns in Maryland to determine how best to move traffic through the CBDs of Denton, Hagerstown, Frederick, Annapolis and Salisbury. In general the SRC chose to bypass the downtown areas by building new highways outside the town limits, where land was less expensive and less populated. Depending on the amount of traffic, some of the bypasses, such as Glen Burnie, were designed with limited access, while others have at-grade, signalized intersections, such as Berlin. In the case of the Pocomoke City, the US 13 Bypass eliminated an at-grade railroad crossing of the Pennsylvania Railroad on the east side of town.

In Worcester County, US 113 was a colonial post road that paralleled the western shore of Sinepuxent Bay and passed through Berlin. In 1939, the SRC District 1 Engineer recommended that US 113 from Selbyville, Delaware through Berlin and Snow Hill to the Virginia line should be modernized due to increased traffic. Starting in 1955, the SRC

⁵² Bruce M. Grey, Personal communications with Anne E. Bruder, SHA, Baltimore, MD October 7, 2009. Traffic continued to grow and in 1969, the SRC began widening portions of the Beltway.

⁵³ URS Corporation for Maryland Transportation Authority, “Maryland Interstate Highway Section 106 Exemption Resource Report, Statement of Significance,” 10/1/2009.

constructed a two-lane undivided highway between the Virginia and Delaware borders bypassing Snow Hill, Newark and Berlin to the east.

Although not formally noted as a bypass, US 240 (I-270) did bypass both Rockville and Frederick. That highway's construction helped spur a different kind of development in the mid-1950s when the federal government began to seek locations outside the District of Columbia



Figure 12: Atomic Energy Commission Complex, Germantown, Montgomery County looking southeast at MD 118 (foreground) and US 240 (now I-270) in background⁵⁵

for the scientific and intelligence agencies such as the Atomic Energy Commission and the National Security Agency. In studying some fifty possible locations for the Atomic Energy Commission headquarters, its General Manager noted that a dairy farm in Germantown was located next to a "beautiful new highway." When the AEC headquarters was dedicated in November 1958, President Eisenhower flew between the White House and Germantown but on the return trip, drove back to the White House from Germantown on US 240.⁵⁴ The distance of the AEC headquarters from Washington ensured that it would be a safe haven for the federal government in case of a nuclear attack (Figure 12).

Other federal scientific agencies located along suburban highways included the Goddard Space Flight Center on MD 295 and the National Institute of Standards and Technology on I-270. All of these agencies were placed outside Washington because there were aspects of the work that required greater security. The distance from Washington helped to ensure the security, but agency personnel could easily return to Washington for meetings when necessary.

In Salisbury starting in 1958, the SRC first proposed to construct a parkway and then extend the highway through the city north of the CBD as a thruway. The roads through Salisbury carried traffic north and south between Virginia and Delaware, as well as east and west between Ocean City and Baltimore. A February 26, 1957 *Salisbury Times* article described the new road as both a parkway and a thruway because of the traffic congestion relief that was anticipated by Salisbury's citizens and the SRC. In contrast, the same newspaper article describes the SRC's decision to build a US 13 bypass around Princess Anne that would be a "boulevard." The difference between the two highways was the location of the highway. US 50 Business had four lanes in town, while US 13 Bypass also had four lanes, but outside the town limits.⁵⁶

Both the SRC's plans and the Sanborn Insurance Company maps for Salisbury show the residential and commercial areas that were demolished in order to build the highway. The new

⁵⁴ Anne E. Bruder, Atomic Energy Commission MIHP No. M:19-41, MIHP form on file with Maryland Historical Trust, Crownsville, MD, December 18, 2006.

⁵⁵ Source: US Department of Energy Archives

⁵⁶ *The Salisbury Times*, "Work to Begin on Parkway This Year," February 26, 1957, P. 1. See also articles from the *Salisbury Times*, "Ask Condemnation of Church Property," November 6, 1958, P. 1, and "Speed Assured on Completion of Route 50 Thruway," August 22, 1959, P. 1. Princess Anne is the Somerset County seat south of Salisbury.



Figure 13: US 50 looking west towards Baptist Street, Salisbury (photo by Carol Ebright, SHA, 2007)

highway divided the City and forced the relocation of many African Americans living in the Cuba and Georgetown neighborhoods to the northern edge of Salisbury. In addition, the SRC relocated 889 graves from the City's public cemetery onto the remaining portion of the cemetery south of the new US 50 alignment. Both US 13 and the Pennsylvania Railroad also crossed the US 50 alignment east of the Wicomico River. These important transportation routes could not be relocated, and the SRC lowered US 50 in order to pass under them. The SRC completed the four-lane highway in 1964 (Figure 13).⁵⁷

Federal Highway Act of 1956

The biggest change to Maryland's highway and bridge construction plans occurred in 1956 with the passage of the Federal Highway Act of 1956, which mandated a 41,000 mile nationwide highway system. President Dwight D. Eisenhower succeeded in persuading both the governors of forty eight states and Congress that it was necessary for the country to have an integrated highway system that would allow people to travel by automobile from one place to another without encountering stoplights or stop signs at intersecting roads. While there was dissent about constructing the interstate system, most Americans and their leaders agreed that a modern system would help improve the economy, increase driver and automobile safety, and benefit the nation.⁵⁸

By 1956, the discussions about creating a national highway system had been ongoing for twenty years. One of the Congressional authors of the act was Representative George H. Fallon of Baltimore, who was Chairman of the House Public Works Committee's Subcommittee on Roads. He had been a supporter of the Baltimore-Washington Parkway and his knowledge of the funding plans for both Maryland's Five Year Program and the Twelve Year Program provided him with the framework for the federal funding plan. It also made him willing to work with Representative Hale Boggs (LA) and his highway funding bill. Boggs was a Member of the House Ways and Means Committee and his plan called for increasing the federal gas tax by one cent, as well as using other highway user taxes. Senator Albert Gore Sr. of Tennessee was Fallon's financial counterpart in the United States Senate. The Secretary of the Treasury George Humphrey recommended that a highway trust fund be created to designate the highway monies from increased gas tax and user fees. Together they put together the funding solution for financing the interstate system. The Federal Government agreed to partner with the states, with the federal government paying ninety percent, and each state paying ten percent of the highway construction costs throughout the nation based in part on the interregional road system first considered by President Franklin Roosevelt.⁵⁹

⁵⁷ Murphy, Brooke, "Segregation Lingers in Wicomico County," *Exploring the Chesapeake's Forgotten River: Perspectives on the Wicomico* Downloaded from http://faculty.salisbury.edu/~mllewis/wicomico_river/chapter_four.htm 10/27/2009 ; see also, *The Salisbury Times*, "Work to Begin on Parkway This Year," February 26, 1957, P. 1,

⁵⁸ Among the dissenters were the architectural critic, Lewis Mumford and planner, Jane Jacobs. Mumford's article "The Highway and the City," *The Highway and the City*, New York: Harcourt, Brace and World (1958), pp. 234-246; and Jacobs' book, *The Death and Life of Great American Cities*, New York: Random House (1992) lay out their arguments against interstate highways, especially in cities.

⁵⁹ Richard H. Weingroff, "Federal-Aid Highway Act of 1956: Creating the Interstate System," *Public Roads* (1996) downloaded from www.fhwa.dot.gov/infrastructure October 6, 2009

Maryland was designated to have 354 miles of interstate, and by the 1960-1962 Biennial Report, 120 miles were open to traffic. This included a portion of the Jones Falls Expressway (I-83) which was then under construction in Baltimore City, and expected to open in late 1962.⁶⁰



Figure 14: Jones Falls Expressway looking south near North Avenue (SHA Photo Archive)

The interstate extended from Baltimore County and the Baltimore Beltway (I-695) to Lombard Street in the CBD (Figure 14). The elevated highway was constructed on structure through much of the City over the Jones Falls. Since it appeared that the City's residents would be able to get downtown more easily with the new highway, local business groups applauded the advent of the Expressway, as did Mayor J. Harold Grady:

Even before its completion, this expressway had a favorable economic impact on Baltimore. The possibility of easy and rapid access has opened the eyes of planners and investors to the great potentials of heretofore 'bypassed' areas. It has inspired plans for new industrial, commercial and residential development – particularly in the category of high-rise middle and upper-income apartments.⁶¹

Mayor Grady's comment is a reference to the urban renewal project at Charles Center, 100 North Charles Street in Baltimore, the high rise office building that had been designed by the architect Mies van der Rohe, and his Chicago development partners in 1962. This was Baltimore's premier urban renewal project in the CBD. Grady's comment also references the upper income high-rise apartments located on North Charles Street, north of Johns Hopkins University, but these were located well outside the CBD. The ten apartment buildings that were constructed in the 1950s and 1960s in the area do not include any public housing units and the area was not a blighted area near the CBD. One of the high rise buildings on North Charles Street is the Highfield House which also was designed by Mies. The Charles Center development did not include public housing in the CBD.⁶²

Maryland continued to apply for interstate federal aid to finance those highways which were not planned to be toll roads. The first highway project that used interstate funds was I-81, then US 11 in Washington County, which the SRC considered to be a bypass of Hagerstown's

⁶⁰ State Roads Commission of Maryland, *Forging Ahead, An Interim Report FY 1960-1962*, n.p

⁶¹ George White, "Baltimore's Freeways Bring Many Advantages," *Highway User* (December 1962) p. 36-37 downloaded from <http://archives.ubalt.edu/GBC/3-44.pdf> October 7, 2009

⁶² By the early 1960s, Baltimore City had developed several plans for urban interstate roads, but none received universal approval from the City Mayor and Council, business community or affected residents. Most of the roads that were constructed, including I-70, I-395, the Fort McHenry Tunnel and I-95 all date to the 1970s and 1980s.

CBD in Washington County. The various road projects that the SRC had programmed for construction lagged in part because of labor strikes at steel mills, rapidly rising prices and unexpected construction issues. When Governor McKeldin left office in 1959, the SRC developed a new schedule for the highways that were programmed for construction. Under Governor J. Millard Tawes, the SRC committed to the “Go Roads Program,” which required the agency to build 100 miles of new highway every year for five years. Many of the projects were for the secondary highway system within the state – the farm-to-market and feeder roads that connected to the arterials. Despite this aggressive program, several interstate highways as well as US 50 Business in Salisbury and US 301 in Queen Anne’s and Kent counties still required attention.

J. Millard Tawes and the “Go Roads” Program, 1959-1965

Governor J. Millard Tawes was elected to office in 1958, following McKeldin’s two terms. Through McKeldin’s Twelve-Year Program, the SRC had scheduled highway construction until 1965. Although Tawes was a Democrat, and a politician from a smaller, more rural county, he understood the significance of the highway system. Rather than stopping the program, he reorganized the SRC to make it “more efficient.” The SRC’s new proposal for the “Go Roads” Program, wherein 100 miles of highway would be built every year until 1965, received the Governor’s support. The Twenty-Seventh Biennial Report, *Tomorrow’s Roads Today*, for the 1959-1960, states that during this period, “the SRC had widened and resurfaced 365 miles of highway in every part of the state.” At the same time, because of inadequate roads that required dualizing or relocating, it was necessary to expedite construction in order to focus on the primary road system.⁶³

The primary road system had been in place since 1916 when the SRC first began receiving federal aid for highway construction. The agency identified a system of highways that would connect all of the county seats with Baltimore and with one another within various regions throughout the state. By 1952, the state had approximately fifty five highways in the primary system. The 1959-1960 Report underscored the difference between the state’s primary road system and the secondary highway system which consisted of smaller feeder roads that connected to the primary system. As reported in the Exhibits for the Report, the primary road system highways that were improved during 1959-1960 included MD 51 in Allegany County, US 301 and MD 2 in Anne Arundel County, and MD 404 in Caroline County. Several of these roads were important because they were outside the Baltimore-Washington-Annapolis-Frederick area, and provided citizens in more distant parts of the state with safe, modern highways. The secondary road system also received attention; however, the heart of the SRC’s message was that the agency remained focused on meeting the construction deadline for the interstate since the federal government planned to end the program in 1969.⁶⁴

Among the highways that the SRC planned to complete as interstates were the Washington Beltway (I-495) and the Northeast Expressway (I-95) between White Marsh Road and the Delaware State Line. The 1959-1960 Report also identified the I-95 segment between Washington, DC and Baltimore, I-70 west of Frederick and the East-West Expressway through Baltimore as roads that remained to be constructed.⁶⁵ By the end of Fiscal Year 1960, the SRC

⁶³ State Roads Commission of Maryland, *Twenty-Seventh Biennial Report, Tomorrow’s Roads Today, for the 1959-1960*, Baltimore, MD 1961

⁶⁴ *Ibid.* p. 4, and pp. 94-101

⁶⁵ Because Baltimore is an independent city with an ability to generate its own revenue through taxation, so it also maintains control of the state highways within its borders (I-83, MD 2, MD 139, MD 147, US 1, US 40). However, it does not maintain control of I-95 or I-895.

had constructed 112 miles of interstate that was open for travel, while 35 miles of highway were then under construction. Maryland received eighty two percent of the federal aid allotment, while Baltimore City received forty percent. The interstate highways that had been completed included the Baltimore-Harrisburg Expressway (I-83), which was the relocation of Baltimore-York,



Figure 15: I-83 looking north towards Shawan Road
(Source: SHA Photo Archive)

Pennsylvania Turnpike in northern Baltimore County. Since the 1930s York Road had been identified as one of the dangerous roads with steep grade that made the road dangerous, the SRC expanded the road to a four-lane divided highway with access to York and Harrisburg, Pennsylvania (Figure 15). In addition, portions of the Capital Beltway had also been completed.⁶⁶

Capital Beltway

Like the Baltimore Beltway, the Capital Beltway's (I-495) design originated from the planning done by the Maryland-National Capital Park and Planning Commission (M-NCPPC), which as early as 1952 had drawn an alignment through both

Prince George's and Montgomery counties with crossings over the Potomac River on the west and south sides of Washington, DC. Discussions continued about a possible ring road around the District's boundary that would connect the radial roads extending from downtown Washington, DC such as Georgia Avenue, Wisconsin Avenue, New Hampshire Avenue, and US 1, which all extended into Maryland on the north side of the City. Early forms of suburban development occurred along these radial roads, as well as in the areas in between them. After initial agency discussions, no further planning occurred about the ring road, although there was general agreement between the State and County agencies that such a highway was needed. Following World War II, the Washington metropolitan population continued to grow due to the presence of government jobs; however, the residents chose to live outside of the City in Montgomery and Prince George's counties. Consequently, traffic congestion significantly increased as more residents purchased automobiles for commuting between their jobs and home.⁶⁷

On March 15, 1954, fifty federal, state, and local agencies agreed to construct the bi-state highway which would lie approximately twelve miles beyond the District's boundary in Virginia and Maryland. Maryland's initial portion would be thirty-three miles long in Prince George's and Montgomery counties. In addition to a four lane highway separated by a median and interchanges with the radial roads, the highway would require two bridges, one at the south end of the highway between Oxon Hill, Maryland and Alexandria, Virginia and the second between Cabin John, Maryland and Langley, Virginia. Shortly after the meeting, the SRC hired the engineering firm of Michael Baker, Jr. of Pittsburgh, Pennsylvania to oversee the construction of the Capital Beltway.

⁶⁶ *Op. cit.*

⁶⁷ Frederick Gutheim, *Worthy of the Nation, The History of Planning of the National Capital*, Washington, DC: Smithsonian Institution Press (1977) p. 273. In *Worthy of the Nation*, Gutheim states that the Capital Beltway was the first circumferential expressway constructed in the nation. While discussions about a ring road outside the District's boundary began in the late 1940s, Baltimore City and Baltimore County also began planning for the Baltimore Beltway and construction began in 1953 and the highway was completed in 1962.

Although Baker was not a Maryland engineering firm, it was one of thirty firms that received contracts with the SRC to complete certain projects that were included in the Twelve-Year Plan.⁶⁸

While design planning continued, the SRC first began to improve the radial roads which had become state highways once they passed into Maryland in Montgomery and Prince George's counties. The first road to be improved was MD 97, Georgia Avenue, which was rebuilt as an urban, two-lane highway in 1952. In 1955 and 1956, the SRC Report noted that Columbia Pike (US 29), New Hampshire Avenue (MD 650), MD 5 (Branch Avenue) had all been dualized in anticipation of connecting the circumferential routes, particularly the Capital Beltway.⁶⁹ By 1960, the SRC programmed \$75,000,000 in the two counties to complete extending the radial roads to the Beltway.

In 1955, the SRC began construction of the circumferential highway between the Indian Head Highway (MD 210) and the Palmer Highway (MD 704) in Prince George's County. At the same time, the Capital Beltway's construction in Montgomery County also began in 1955 starting with the Cedar Lane overpass east of Wisconsin Avenue. This segment of the highway was rather controversial because it passed through the Maryland portion of the Rock Creek Park which in the District of Columbia is a federal park, purchased with funding from the Capper-Crampton Act of 1930. In Maryland, the M-NCPPC purchased portions of the park lands using the Capper-Crampton Act funding, although the county agency also received state funds for park land purchases. Local residents living in Chevy Chase near the highway opposed construction of the Beltway through the park because of the damage to the trees, as well as the potential damage to the residential property values. Many of the opponents were among Washington's political and business elite, unlike the residents in Prince George's County near the Indian Head and Palmer highways. Although their objections were considered, the county and federal agencies, the M-NCPPC and the National Capital Planning Commission (NCPC), overruled their objections and agreed to allow the SRC to construct the highway.⁷⁰

The SRC completed construction of the 1.5 mile segment of the highway near Wisconsin Avenue in 1957. By then, other portions of the highway had been constructed between Wisconsin Avenue in Montgomery County and Kenilworth Avenue in Prince George's County, but it was not complete. Governor McKeldin and his wife both cut ribbons to celebrate the completion of the two interchanges. Mrs. McKeldin cut her ribbon near Wisconsin Avenue and the Governor cut his at Kenilworth Avenue, which was fifteen miles to the east.⁷¹ The SRC designed metal girder bridges in both interchanges.

The SRC called the highway the Capital Beltway, and it was opened in August 1964 and was immediately widened from two lanes to three lanes. Although the SRC had constructed some of the Beltway's multi-beam bridges before there was a highway to connect to, one large bridge across the Potomac River required nonstandard design. The Woodrow Wilson Bridge between Oxon Hill, Maryland and Alexandria, Virginia was designed as a memorial to the former

⁶⁸ Jeremy Louis Korr, *Washington Main Street: Consensus and Conflict on the Capital Beltway, 1952-2001*, University of Maryland, College Park, MD (2002), p. 111, State Roads Commission of Maryland; *Report of the State Roads Commission of Maryland, 1955-1956*, Baltimore, MD: 1956, p. 11

⁶⁹ State Roads Commission of Maryland, *Report of the State Roads Commission of Maryland, 1951-1952*, Baltimore, MD: 1952, p. 137; and State Roads Commission of Maryland, *Report of the State Roads Commission of Maryland, 1955-1956*, Baltimore, MD: 1952, p. 147.

⁷⁰ *Op. cit.*, pp. 126, 152 and 180-182

⁷¹ *Op. cit.*, pp. 126-127



Figure 16: Woodrow Wilson Memorial Bridge, I-495 over the Potomac, looking east toward Maryland (SHA Photo Archive)

President. It was a steel girder and double bascule span bridge with the tender's house at the draw span near the Virginia shoreline (Figure 16).⁷²

The highway was an important component of Maryland's interstate system because its completion provided connections between Washington's suburbs and Frederick and Baltimore, and from Baltimore to Philadelphia and New York. The new highway also helped to remove through traffic from downtown Washington DC. Several more highways needed to be completed by 1965 in order for the SRC's interstate program to be finished: the Northeast Expressway (I-95) between Baltimore and the Delaware State Line, and I-70 between Baltimore and Frederick, as well as the I-70 portion from Frederick to Hancock, where the road enters Pennsylvania.

Northeast Expressway/I-95/Kennedy Memorial Highway

The Northeast Expressway (I-95) between Baltimore and either the Pennsylvania or Delaware State Lines was a highway that the SRC had long planned to complete. MD 7, the Philadelphia Road, started in the eighteenth century as the post road between Baltimore and Philadelphia. The SRC took it over in 1908 and upgraded it through the mid-1930s when it became clear that the development ringing the road would prevent the agency from making it wider and safer. Between 1936 and 1939, the SRC relocated the road and built a four-lane highway, divided by medians, with a full width of 80 feet to support the two roads between Baltimore and the Delaware state lines and called it US 40. During World War II, local and out of state drivers as well as residential and commercial developments in Aberdeen created congested traffic conditions along this new highway. The SRC planned to construct a third northeast highway that would have limited access and possibly two legs, one going towards Delaware and the second going directly to Philadelphia. Although the SRC discussed the road during the early portions of the Twelve-Year Program, other projects had a higher priority and so it was programmed for funding at a later time. In order to meet Governor Tawes' schedule and to get the highway scheduled for construction, in 1959 the SRC chose to use bond money to fund the work.

When the Federal Highway Act of 1956 passed, a northeast highway between Baltimore and the Delaware State Line was shown on the map as part of the 41,000 mile system. However, as the SRC struggled to complete Maryland's interstate portion in a timely fashion, it was apparent there would not be sufficient funding to complete every planned project on schedule.

An issue in 1962 was whether or not a toll road could be incorporated into the interstate system. The federal requirements prohibited toll roads if they were not on the selected alignment for that portion of the interstate. In Maryland, the Northeast Expressway took the same course that was recommended in the Interstate Report for the interstate highway between Baltimore and Philadelphia, so that the toll road met the federal requirement and could be constructed. The highway extended from northeast Baltimore for forty-two miles. The SRC built the highway for six lanes of traffic, but it began with four traffic lanes, while the deck truss bridge over the

⁷² The bridge was replaced by the new Woodrow Wilson Bridges between 2006 and 2008.



Figure 17: Governor Elbert N. Carvel of Delaware, President John Kennedy and Governor Millard Tawes of Maryland – I-95 Ribbon Cutting (SHA Photo Archive)

Susquehanna was opened with six traffic lanes. The highway required \$102,000,000 in bonds, and construction began in February 1962, and was completed by November 1963. President John F. Kennedy came to opening of the highway and spoke about the importance of the interstate system to the county's economy on November 14, 1963 (Figure 17). I-95 and its Maryland House in Cecil County was opened to all drivers, including African-Americans, which spurred other calls for more public accommodations in Maryland and elsewhere affected by segregation.⁷³

Meeting the Twelve Year Program Goal

In February 1963, the SRC issued a new report, *Maryland Highway Needs Study, A Progress Report*, which stated that by 1965, the agency expected to build US 50 as a divided four-lane highway between Cambridge and Ocean City; construct US 301 as a four lane divided highway from US 50 at Queenstown to the Delaware State Line, make improvements to US 40 and US 219 near Keyser's Ridge in Garrett County, construct a new interstate highway, I-81 in Washington County, and widen MD 4 in Prince George's and Calvert Counties, as well as dualizing US 340 and US 15 in Frederick County. These roads were outside the Baltimore-Washington corridor, and provided safe new highways for residents who lived outside the center of the state. Many of these roads, connecting major cities and states, were shown on the state highway map in 1952 as part of the SRC's Primary Road Program and were the final projects that the SRC believed needed to be constructed in order to provide the new state highway system. Like earlier highways constructed as part of the Twelve Year Program, the SRC also constructed metal girder and reinforced concrete bridges on these highways.

Conclusion

With the achievement of modernizing each of the highways, the SRC had completed its Twelve-Year Program goal of constructing or reconstructing 3,452 miles of highway and 557 bridges throughout the state between 1948 and 1965. Maryland had a road system of primary and secondary highways that had been brought up to the safety and design standards set by the SRC in 1953. The majority of the planned interstate system had also been constructed. Aside from the interstate highways in Baltimore City, the SRC would be responsible for constructing I-95 between the Washington Beltway and Baltimore in the late 1960s and early 1970s, and I-68, the National Freeway, from Hancock to the West Virginia border in the 1980s and 1990s. The Baltimore sections of the interstate would require repeated studies, meetings, court battles and intermittent construction until the 1980s when the Fort McHenry Tunnel was completed to connect the south leg of I-95 with the northeast leg.

⁷³ *The Baltimore Evening Sun*, "President Kennedy is Dedicating New Maryland-Delaware Turnpike Link," November 14, 1963, page A2, Enoch Pratt Free Library Maryland Department; "Northeast Expressway," *Baltimore Magazine*, February 1962, Enoch Pratt Free Library Maryland Department. This was the only time that a President had opened a highway, and this segment of I-95 memorializes Kennedy who was killed a week later. Maryland State Roads Commission, *Moving Maryland Forward, A Century of Modern Road Building*, Baltimore, MD: Maryland Department of Transportation, State Highway Administration, 2008, p. 72.

The SRC completed its eighteen-year construction program in a timely manner, and had provided an improved highway system for the State. These public works projects altered Maryland's landscape and changed the way its residents and other drivers were able to drive through the state with ease and speed that had not been imagined before the "Five Year," "Twelve Year" and "Go Roads" Programs were started. The 1965 highway map shows lines on paper in two dimensions that can not adequately explain the miles of earth that were graded and the amounts of concrete that were poured for new highways, or the pounds of steel that became highway bridges. In order to comprehend the change, it is necessary to drive the highways, as many of Maryland's citizens did after 1965. Traffic continued to grow after 1965, as did the state's population, but the SRC planned for alterations as part of the continued development of Maryland's highways.

Prior to 1948, Maryland's highways were narrow and dangerous, which was caused by poor engineering, lack of right-of-way and large amounts of unplanned traffic. In order to build a new system, the SRC took into account the need for future expansion of every highway. Large swaths of right-of-way were purchased to ensure that any future highway development would be completed without impediments from nearby commercial and residential lane use, as had been the case on US 1 and US 40 after World War II. Alterations to some highways occurred almost as soon as the original construction was completed. As noted above on I-495, the Capital Beltway, the SRC started construction in 1955 with the Cedar Lane overpass, but by 1964, needed to widen and realign the highway through Rock Creek Park in Montgomery County. Rapidly increasing traffic on the road required the SRC to widen it to three lanes in each direction, including widening each of the I-495 bridges. As the noise levels of the traffic increased, the SRC installed noise walls to protect nearby residents and businesses from the incessant sound of trucks and cars. Likewise on I-695, the Baltimore Beltway, during the early 1960s, the SRC installed safety fencing in order to prevent nearby pedestrians from crossing four lanes of high speed traffic. Noise barriers were built as the highway was widened to six lanes, and moved closer to nearby residential and commercial areas. By the late 1980s in Prince George's County, the NPS and SHA began to replace bridges over the Baltimore-Washington Parkway and to widen MD 295 from two to three lanes near I-495 because of the large daily traffic amounts on both the parkway and its cross roads. Increasing residential and commercial development in the 1990s in Anne Arundel County caused the widening of US 50 from the Patuxent River to the Chesapeake Bay Bridge from four to six lanes. Traffic on the first bay bridge had become so heavy that in 1972, a second three-lane bridge was opened parallel to the first. Most of these alterations occurred without requiring SHA to purchase large amounts of new right-of-way because of the planning that occurred before the highways were first built. These types of alterations however, have caused changes to the original design of the highways and the bridges associated with them, lessening their integrity.

The Maryland State Highway Administration has previously identified and evaluated forty-four bridges from the 1948-1965 period; thirty-eight metal girder or stringer/multi-beam or girder or concrete box beam bridges have been determined not eligible for the National Register of Historic Places (NRHP) because they are common resources found on every Maryland highway. The six SHA bridges that have been determined eligible for the NRHP are: the Blue Bridge (MD 942 over the Potomac, SHA Bridge No. 0106600) in Cumberland, Allegany County; the Aluminum Bridge (Old MD 32 over River Road, CSX and the Patapsco River, SHA Bridge No. 1304600) near Sykesville, Carroll County; MD 151 over Patapsco and Back River Railroad and MD 151B (SHA Bridge No. 0309900), Baltimore County; MD 231 over Patuxent River (SHA Bridge No. 0400800) near Benedict, Charles County; MD 32 over Liberty Reservoir

(SHA Bridge No. 0604900), Carroll County; and US 113 Business over Purnell Branch (SHA Bridge No. 2300800), Worcester County. The Blue Bridge is an example of a steel through arch bridge, one of five in Maryland, while the Aluminum Bridge is a box girder type bridge and one of six aluminum bridges in the United States, MD 32 is an example of a deck truss that was constructed in conjunction with the Liberty Reservoir construction in 1952, while MD 231 is the only movable swing type bridge built during this period in the state. As a result of the two new historic context studies, SHA will also recommend as eligible a bascule span movable bridge, MD 18B over Kent Narrows (SHA Bridge No. 1700500), Queen Anne's County; and a second deck truss, MD 144 over the Monocacy River (SHA Bridge No. 1003803), Frederick County. Each of these bridges provides unique solutions for their locations. Two bridges, MD 151, a metal girder example that was constructed by Bethlehem Steel Bridge Company at the entrance to the Bethlehem Steel Mill at Sparrows Point, and US 113, which is a concrete slab bridge from 1952, are representative examples of the highway bridges that the SRC typically built during the study period. Since it a box girder example, the Old MD 32 bridge is also an example of the more usual types of bridges that the SRC constructed but its materials make it unique.

Of the 557 bridges built on the state highway system between 1948 and 1965, 485 are classified as stringer/metal beam or girder bridges or what SHA previously classified as rolled or plate metal girder bridges. The next largest bridge type is also a metal girder type, the girder and floorbeam system structures, of which there are seventeen. Thirteen rigid frame, eight slab and eight Tee-beam are the most common reinforced concrete types found in Maryland from the study period. The box beam or girder type can be either metal or concrete and there are twelve examples on state highways. The preponderance of rolled or plate girder bridges on the state highways speaks of the practical ways in which the SRC made use of standardization to complete their highway construction efforts.

The question arises how to demonstrate the NRHP significance and eligibility of the 286 bridges included in this study. Readily-identifiable changes from the 1930s rolled or plate metal girder bridges are limited to solid wall parapets rather than open baluster railings and less use of concrete since the girders were not encased but were painted after 1948. These are minor changes in bridge design, and helped to reduce overall construction and maintenance costs. The size of the girders also increased after 1948 in response to heavier traffic amounts, but the method of design and construction of both the individual girders and the bridges did not change. The bridges became larger and there were more of them, but in the 1948-1965 period, bridge designs did not change from the 1930s. SHA has not identified any technological innovation in the post-war bridges that make them different from the earlier structures. The overriding design principal for all the highways and bridges was driver safety, and the SRC most frequently relied on the post-and-beam construction that metal girder bridges exemplify because these were simple to design and construct and required minimal upkeep once built, unlike other types of bridges. Even movable bridges such as MD 18B over Kent Narrows and MD 231 over Patuxent River have metal girder (steel beam) approach spans because construction of these bridges could be quickly accomplished. In some instances, the SRC used reinforced concrete bridges that reduced design and construction times. Some of these bridges are pretensioned concrete, which was used nationwide by many of the state Departments of Transportation because it allowed the bridge elements to be precast off site. None of these rigid frame, slab or Tee-beam bridges however, introduced new innovations in designs that were different from earlier pre-war examples. These bridges also grew in size and appeared more frequently because of the number of highways crossing streams, other roads and railroads. In short, these bridges were constructed as part of a larger highway system that was designed to ensure driver and vehicle safety.

The mid-century bridges were not constructed as the single most important element of the highway system, nor were they unusual designs. Rather, the bridges were constructed as an integral part of the associated highway, and there were many bridges on each highway that crossed other roads, railroads, and bodies of water along the route. Although the SRC constructed many bridges and highways during the 1948-1965 period, that is not an exceptional event. During this same period, other state Departments of Transportation such as Delaware, New Jersey, Virginia, Nebraska, Tennessee, Oregon and California were constructing similar bridges and highways in order to keep up with growing traffic on state highways. The steel beam and girder bridges and reinforced concrete bridges constructed during this period by the SRC became a common resource found on every highway in the state and in many other states as well. As a result, SHA does not recommend any of the remaining 286 bridges as eligible for inclusion in the National Register of Historic Places Criteria A (events) or C (engineering) because it is our determination that all of these bridges are common, ubiquitous structures.

Bibliography

American Association of State Highway Officials, *A Story of the Beginning, Purposes, Growth, Activities and Achievements of AASHO*, Published on the Occasion of the Golden Anniversary of American Association of State Highway Officials, ed. A. E. Johnson, Washington, DC: American Association of State Highway Officials (1965)

_____. *Standard Specifications for Highway Bridges, 6th Edition*, Washington, DC: Association General Offices (1953)

Arnold, Joseph L., "Baltimore Southern Culture and A Northern Economy," *Snowbelt Cities, Metropolitan Politics in the Northeast and Midwest since World War II*, ed. Richard M. Bernard, Bloomington, IN: Indiana University Press (1990), pp. 23-39

Michael Baker Corporation, *Comprehensive Company History*," downloaded from www.mbakercorp.com 10/15/2009

The Baltimore Evening Sun, "President Kennedy is Dedicating New Maryland-Delaware Turnpike Link," November 14, 1963

_____, "Baltimore Itself Is Bottleneck in Highway Plans, Say Experts," March 13, 1941

The Baltimore Sun, "45 Minutes to Washington," October 24, 1954

Blair, Melissa F., DOE AN-0101, SHA Bridge No. 0201900, Ridge Road over MD 295, 11-15-2005, on file at the Maryland Historical Trust, Crownsville, MD

Brean, Herbert, "Dead End For The US Highway – The Horrible History Of One Road Explains Why The US Is Closer Than It Realizes To Being Immobilized By A Network That Is Obsolete, Wasteful And Murderous," *Life* Vol. 38 (May 30, 1955)

Brooks, Neal A. and Eric R. Rockel, *A History of Baltimore County*, Towson, MD: Friends of Towson Library, Inc. (1979)

Brown, Jeffrey, *A Tale of Two Visions: Harland Bartholomew, Robert Moses, and the Development of the American Freeway*, downloaded from www.uctc.net/papers/659.pdf, April 7, 2010 (paper given at TRB 2003 Annual Meeting, Washington, DC)

Bruder, Anne E., "The Baltimore-Washington Parkway: The Modern Highway in the Suburban Context," paper delivered April 2000 to Historic Roads Conference, Morristown, NJ

_____, "No Bridge too Far, Maryland's Historic Bridges," paper delivered October 2000, at St. John's College, Annapolis, MD

_____, MIHP form for the Atomic Energy Commission MIHP No. M:19-41, on file with Maryland Historical Trust, Crownsville, MD

City of Baltimore, Department of Public Works, "The Interstate System in Baltimore," 1964

- Freedman, Earle S., Director, Office of Structures, Personal Communication with Anne E. Bruder, SHA, Baltimore, MD March 18, 2010
- Gillette, Howard, Jr., "A National Workshop for Urban Policy: The Metropolitanization of Washington, 1946-1968," *The Public Historian* (Winter 1985),
- Greiner Engineering Company, *The Maryland Transportation Authority Annual Toll Facilities Report*, Baltimore, MD (1941)
- _____, *Maryland's Primary Bridge Program*, Baltimore, MD (1938)
- _____, *Report Submitted to State Road Commission of Maryland, Washington-Baltimore Freeway from Jessup's Road, Including Highway Approaches to the Patapsco River Bridge and Franklin Street Connection* (1944)
- Grey, Bruce M., Deputy Director, Office of Planning and Preliminary Engineering, Personal Communication with Anne E. Bruder, SHA, Baltimore, MD, October 7, 2009
- Korr, Jeremy, "Political Parameters, Finding a Route for the Capital Beltway, 1950-1964," *Washington History*, 2007-2008, pp. 4-29
- _____, *Washington's Main Street: Consensus and Conflict on the Capital Beltway, 1952-2001* (Ph.D. diss., University of Maryland College Park, 2002)
- Kramer, George, *The Interstate Highway System in Oregon, A Historic Overview*, Salem, OR: Oregon Department of Transportation (May 2004)
- Lane, William Preston, "A Message to the General Assembly by Governor William Preston Lane, Jr. on the State Highway System," March 6, 1947, Maryland Department, Enoch Pratt Free Library, Baltimore, MD
- Lewis, Tom, *Divided Highways, Building the Interstate Highways, Transforming American Life*, New York, NY: Viking, Penguin Group (1997)
- Mackintosh, Barry, "Shootout on the Old C. & O. Canal: The Great Parkway Controversy, 1950-1960," *Maryland Historical Magazine*, Vol. 90, No. 2 (Summer 1995) pp. 141-163
- "Major Transportation Milestones in the Baltimore Region Since 1940," downloaded from www.baltometro.org/reports/MajorTransMilestones.pdf
- Maryland Historical Trust, MIHP Form No. B-4542, SHA Bridge No. BC-1202, Orleans Viaduct, on file at Maryland Historical Trust, Crownsville, MD (1995)
- Maryland-National Capital Park and Planning Commission, *Suggested Program for Highway Development in the Maryland-Washington Regional District in Montgomery and Prince George's Counties, 1952-1962* (1951)
- Maryland State Archives, Chapter 487 and Chapter 858 of the Acts of 1941, www.msa.md.gov/megafile/msa/speccol

_____, Expressway Act of 1947, Vol. 411, Page 1383 of the On-line Archives at www.msa.md.gov/megafile/msa/speccol.

Maryland State Planning Commission, *Ten Year Highway Construction Program for Maryland*, Baltimore, MD (1935)

_____, "Baltimore Regional Planning Council Technical Report No. 3, Freeway Plan," May 1959

McCain, Russell H., "Financing the Highway Program in the State of Maryland," *American Highways*, Vol. XXXIV, No. 2, April 1995, p. 13

McCarthy, Michael P., "Baltimore's Highway Wars Revisited," *Maryland Historical Magazine*, Vol. 93, No. 2 (Summer 1998), pp. 136-157

Mohl, Raymond A., "Planned Destruction, The Interstates and Central City Housing," *From Tenements to the Taylor Homes, In Search of an Urban Housing Policy in Twentieth-Century America*, Ed. John F. Bauman, Roger Biles and Kristin M. Szylvian, University Park, PA: the Pennsylvania State University Press (2000), pp. 226-245

_____, "Stop the Road: Freeway Revolts in American Cities," *Journal of Urban History*, 2004, pp 674-706

_____, "the Interstates and the Cities: The U.S. Department of Transportation and the Freeway Revolt, 1966-1973," *The Journal of Policy History*, Vol. 20, No. 2 (2008), pp. 193-224

Mumford, Lewis, *The Highway and the City*, New York, NY: Harcourt, Brace & World, Inc. (1963)

Murphy, Brooke, "Segregation Lingers in Wicomico County," *Exploring the Chesapeake's Forgotten River: Perspectives on the Wicomico* Downloaded from http://faculty.salisbury.edu/~mllewis/wicomico_river/chapter_four.htm 10/27/2009

"Northeast Expressway," *Baltimore Magazine*, February 1962

The Ohio Department of Transportation, *The Third Ohio Historic Bridge Inventory, Evaluation, and Management Plan for Bridges Built 1951-1960 and the Development of Ohio's Interstate Highway System*, downloaded from [http://www.dot.state.oh.us/Divisions/TranSysDev/Environment/Cultural_Resources/Historic Bridges](http://www.dot.state.oh.us/Divisions/TranSysDev/Environment/Cultural_Resources/HistoricBridges) (2004)

"Ohio's Super-Highway," *Time* Vol. 59, i24 (June 16, 1952) p. 87

Orser, W. Edward, *Blockbusting in Baltimore, The Edmondson Village Story*, Lexington, KY: The University Press of Kentucky (1994)

Public Administration Service, *Maryland's Highways, A Report on an Administrative Survey*, Washington, DC (1952)

- Public Roads*, "State Motor-Vehicle Registrations – 1941," Federal Works Agency, Public Roads Administration, Vol. 23, No. 5 (July-August-September 1942)
- Roadside America, the Automobile in Design and Culture*, Ed. Jan Jennings, Ames, Iowa: Iowa State University Press (1990)
- Rose, Mark H. and Bruce E. Seely, "Getting the Interstate Built: Road Engineers and the Implementation of Public Policy, 1955-1985," *Journal of Policy History*, Vol. 2, No. 1, 1990
- Shore to be Fun, *Delmarva Highways*, downloaded from delmarvausa.com/delmarvahighways, September 24, 2009
- Smith, Nathan L., *Analysis of Traffic Conditions and Present and Post-War Highway Requirements*, Chief Engineer, Department of Public Works, [Baltimore City, MD] to Theodore R. McKeldin, Mayor of Baltimore (May 21, 1945)
- "State Motor Vehicle Registrations – 1941," *Public Roads*, Vol. 23, No. 5 (July-August-September 1942) p. 101; and "State Motor Vehicle Registrations – 1948," *Highway Statistics 1948*, U.S. Department of Commerce Bureau of Public Roads, Washington, DC: US Government Printing Office, 1950
- State Roads Commission of Maryland, *Maryland Highway Needs, 1941-1960, A Report of the State-wide Highway Planning Survey*, Baltimore, MD (1940)
- _____, *Report of the State Roads Commission of Maryland, Operating Report for the years 1935-1936 and Financial Report for the fiscal year 1936*, Baltimore, MD (1937)
- _____, *Report of the State Roads Commission of Maryland, Operating Report for the Fiscal Years 1939-1940*, Baltimore, MD (1941)
- _____, *Report of the State Roads Commission of Maryland, Operating Report for the Fiscal Years 1943-1944*, Baltimore, MD (1945)
- _____, *Report of the State Roads Commission of Maryland for Fiscal Years 1949-1950*, Baltimore, MD (1950)
- _____, *Report of the State Roads Commission of Maryland for Fiscal Years 1951-1952*, Baltimore, MD (1952)
- _____, *Report of the State Roads Commission of Maryland for Fiscal Years 1953-1954*, Baltimore, MD (1954)
- _____, *Report of the State Roads Commission of Maryland*, Baltimore, MD (1916)
- _____, *Report of the State Roads Commission of Maryland, 1951-1952*, Baltimore, MD (1952)
- _____, *Report of the State Roads Commission of Maryland, 1955-1956*, Baltimore, MD (1956)

_____, *Proposed 12-Year Program for Road Construction and Reconstruction, 1954-1965*, Baltimore, MD (October 27, 1952)

_____, *Status of 12-Year Road Construction and Reconstruction as of December 31, 1955*, Baltimore, MD (1956)

_____, *Tomorrow's Roads Today, 27th Biennial Report for FY 1959-1960*, Baltimore, MD (1960)

_____, *Three Economic Impact Studies on a Portion of the Baltimore Beltway*, Baltimore, MD (July 1960)

_____, *Forging Ahead, an Interim Report for FY 1960-1962*, Baltimore, MD (1962)

_____, *Building for the Future, 28th Biennial Report, FY 1961-1962*, Baltimore, MD (1962)

_____, *Maryland Highway Needs Study, A Program Report for State Highways, County Roads and Municipal Streets*, Baltimore, MD (February 1963)

_____, *Paving the Way, 29th Biennial Report, FY 1963-1964*, Baltimore, MD (1964)

_____, *A Highway Report, FY July 1964-June 1965*, Baltimore, MD (1965)

_____, *A Highway Report, FY July 1965-June 1966*, Baltimore, MD (1966)

_____, *Preliminary Report of the Maryland State-wide Highway Planning Survey*, Baltimore, MD, in cooperation with the United States Department of Agriculture, Bureau of Public Roads (1938)

The Salisbury Times, "Work to Begin on Parkway This Year," February 26, 1957, P. 1

_____, "Ask Condemnation of Church Property, November 6, 1958, P. 1

_____, "Speed Assured on Completion of Route 50 Thruway," August 22, 1959, P. 1

U.S. Army Corps of Engineers, *Rivers and Harbors Appropriation Act of 1899* (33 USC §403)

U.S. Department of Commerce, *Statistical Abstract of the United States 1950, Motor-Vehicle Registration*, Washington, DC: US Government Printing Office (1950)

_____, *Highway Statistics 1948 State Motor-Vehicle Registrations - 1948*, Washington, DC: US Government Print Office (1950)

_____, *Highway Statistics 1952 State Motor-Vehicle Registrations - 1952*, Washington, DC: US Government Print Office (1952)

_____, *Highway Statistics 1960 State Motor-Vehicle Registrations - 1960*, Washington, DC: US Government Print Office (1962)

U.S. Department of Transportation, Federal Highway Administration, *America's Highways 1776-1976*, Washington, DC: U.S. Government Printing Office (1976)

URS Corporation, "Maryland Interstate Highway Section 106 Exemption Resource Report, Statements of Significance," Maryland Transportation Authority, Baltimore, MD, 2006

Vaughan, Glenn, Deputy Director, Office of Structures, Personal communication with Anne E. Bruder, SHA, Baltimore, MD March 23, 2010

Weingroff, Richard F., "Federal-Aid Highway Act of 1956: Creating the Interstate System," *Public Roads* (1996), downloaded from www.fhwa.dot.gov/infrastructure/ October 5, 2009

_____, "The Man Who Changed America," Part 1, *Public Roads*, Vol. 66, No. 5 (March/April 2003) pp 20-35

White, George, "Baltimore's Freeways Bring Many Advantages," *The Highway User* (December 1962) pp 36-37 downloaded from <http://archives.ubalt.edu/gbc/3-44.pdf> 10/7/2009

Wixom, Charles W., *ARBA Pictorial History of Roadbuilding*, Washington, DC: American Road Builders' Association (1975)

Appendix A: Results of Field Investigations

SHA examined the bridges on the following highways through field visits and photographs from November 2009 through April 2010:

MD 2 MD 3 MD 4 MD 5 MD 6 MD 7 MD 12 MD 16 MD 17 MD 18B MD 20 MD 22 MD 23 MD 25
MD 26 MD 27 MD 28 MD 31 MD 32 MD 33 MD 34 MD 36 MD 38 MD 41 MD 43 MD 51 MD 53
MD 55 MD 56 MD 58 MD 63 MD 64 MD 67 MD 68 MD 70 MD 75 MD 84 MD 91 MD 97

MD 100 MD 103 MD 109 MD 117 MD 118 MD 122 MD 129 MD 135 MD 136 MD 137 MD 139 MD
140 MD 144 MD 147 MD 151 MD 151B MD 157 MD 165 MD 168 MD 175 MD 176 MD 180 MD
185 MD 190 MD 191 MD 193 MD 194 MD 201 MD 202 MD 208 MD 210 MD 212 MD 213 MD
214 MD 216 MD 224 MD 225 MD 227 MD 228 MD 231 MD 234 MD 242 MD 245 MD 249 MD
254 MD 258 MD 260 MD 272 MD 273 MD 279 MD 281 MD 289 MD 290 MD 291 MD 295 MD
302 MD 306 MD 309 MD 311 MD 313 MD 315 MD 331 MD 333 MD 353 MD 355 MD 376 MD 381
MD 383 MD 390 MD 404 MD 410 MD 413 MD 418 MD 459 MD 491 MD 560 MD 565A MD 586
MD 611 MD 637 MD 650 MD 695 MD 704 MD 726 MD 806A MD 942 MD 946 MD 952

US 1 US 1 ALT US 11 US 13 US 15 US 29 US 40 ALT US 40 US 50 US 50/301 US 113 US 219
US 220 US 301 US 340 US 522

Ardwick-Ardmore Road Auth Road Beaver Creek Road Big Spring Road Boyd Road Catholic
Church Road Cedar Avenue Cherry Hill Road Clara Barton Parkway Cold Bottom Road Comus
Road Crosby Road D'arcy Road Downes Road Ernstsville Road Fernwood Road Forest & Parks
Road Forest Glen Road Forestville Road Freeland Road Glenarden Parkway Greentree Road
Grosvenor Lane Hammonds Ferry Road Hollins Ferry Road Hopewell Road Horine Road Joppa
Road Lanender Road Lillian Holt Drive Mcdade Road Middletown Road Motter Avenue Old
Harford Road Park Mills Road Persimmon Tree Road Putty Hill Road Richie Marlboro Road Ridge
Road Ruxton Road Sandy Mile Road Security Boulevard Seminary Road Solomons Island Road
St Marks Road Stevenson Road Taylor Avenue Temple Hill Road Tridelphia Road Vale Road
Victory Post Drive Walnut Point Road West Nursery Road Windsor Mill Road Windy Ridge Drive

Each of the highways listed above had work done on it during the 1948-1965 period. SHA did not build new bridges on every highway in the state, and there are also small structures and pipes on the highway. These appurtenances were not included in SHA's study because they do not meet the Federal Highway Administration's definition of a bridge. As explained above, bridges on Maryland's interstate system are not included in this study because all are exempted by the ACHP/FHWA Interstate Exemption: IS 68 IS 70 IS 81 IS 83 IS 95 IS 97 IS 270 IS 295 IS 495 IS 595 IS 695 IS 895B

Appendix B: Bridge Types and National Register of Historic Places Eligibility Justification for 1948-1965 Bridges

Twelve different types of bridges were constructed on the state's highways from 1948 to 1965: arch through, arch deck (filled), box beams or girders multiple, concrete slab, concrete encased steel beam, girder and floorbeam system, movable – bascule, movable – swing, rigid frame, stringer metal beam or girder, Tee beam, deck truss. The terms are defined below and in the following Highway and Bridge Terms and Definitions below.

Bridge Types found on Maryland's Highways

Steel Through Arch – The steel through arch generally consists of two fabricated steel ribs constructed with the crown of the arch above the roadway and the arch foundations below the roadway. The deck is suspended from the two steel arches by wire rope cables or other tension members. Traffic loads are transmitted as follows: deck, steel flooring system, cables, arch ribs, and arch foundations. Drivers pass through the two arches.



Steel Through Arch (SHA Bridge No. 0106600 -- Blue Bridge, Cumberland, MD)

Steel Through Truss - similar to Steel Through Arch except traffic loads are transmitted from trusses directly to abutments/piers via bearings, in lieu of arch foundations. The Chesapeake Bay Bridge, Bridge No. 0204000, has several spans of steel through trusses.

Concrete or Steel Deck Arch - The deck arch carries traffic on its deck. There are several types of arches. The oldest type is a filled concrete arch similar to stone masonry arches built over the centuries. This type consists of a solid concrete arch barrel with solid concrete sidewalls (spandrel walls) that contain fill which supports the roadway. Alternately, there are the

open concrete or steel arches that generally consist of two or three concrete/steel ribs that transfer the loads to the arch foundations. Traffic loads are transmitted as follows: concrete deck, concrete/steel flooring members, concrete/steel columns, arch ribs, arch foundations. The sides of the arches are “open” so no fill or embankment is contained. Drivers pass above the arches.



Steel Deck Truss (SHA Bridge No. 0604900, MD 26 over Liberty Reservoir, Carroll County, MD)

Steel Deck Truss - similar to Steel Deck Arch except traffic loads are transmitted from trusses directly to abutments/piers via bearings, in lieu of arch foundations

Multiple Rolled Beams or Multiple Fabricated Girders (also Stringer Multi-Beam/Girder, formerly called Metal Girder Bridge) – rolled beams or fabricated girders that support the deck of the bridge, all supported by the abutments and piers. A rolled I or T Beam is formed as one piece that is extruded from its form, while a fabricated girder consists of flat metal sheets that are welded or riveted together to form a longer/wider/deeper beam.



Multiple Fabricated Girders/Stringer Multi- Beam/Girder (SHA Bridge No. 0210100, MD 2 over US 50, Annapolis, MD). This is an example of multiple girders welded together.

Metal or Concrete Box Beams -- trapezoidal or rectangular sections that support the deck of the bridge and provide greater stability. The concrete box beam bridges could be constructed in areas where there was no traffic passing through the construction site, generally over water where flooding could be an issue. Metal box beam bridges are generally reserved for highway flyover ramps.

Concrete Slab – a reinforced concrete bridge has a deck that is constructed as a single unit spanning the space between the supporting abutments/piers.

Concrete Encased Steel Beam – steel beams that are used as the support for the deck are encased in concrete. Steel beams are erected, then encased on-site, and supported on abutments/piers.

Floorbeam/Girder System -- The concrete deck is supported by a steel flooring system consisting of longitudinal stringers (rolled beams), transverse floorbeams (rolled beams or fabricated girders) and two main fabricated girders supported on abutments/piers.



Concrete Box Beam Bridge (SHA Bridge No. 0802200, MD 225 over Mattawoman Creek, Charles County, MD)

Movable – Bascule – a type of movable bridge where one or two leaves of the bridge deck are raised to allow passage of a boat through the bridge -- generally used on rivers where there is an active water passage. SHA Bridge No. 0336500 (MD 157 over Bear Creek, Baltimore County), No. 1700600 (MD 18B over Kent Island Narrows, Queen Anne’s County) and No. 2202800 (US 50 Business over North Branch of Wicomico River, Salisbury, Wicomico County) are all examples of bascule span bridges built between 1948 and 1965.

Movable – Swing – a type of movable bridge where the span that crosses the water channel will swing around to allow passage of a boat through the bridge. SHA Bridge No. 0400800, MD 231 over the Patuxent River, St. Benedict, Charles and Calvert Counties is an example of a swing span bridge built in 1950/1951.

Concrete Rigid Frame – a monolithic bridge in which the superstructure and the substructure are of one continuous fabric, generally built of reinforced concrete or fabricated structural steel.



Aluminum Box Beam Bridge (SHA Bridge No. 1304600, Old MD 32 over River Road, CSX, and south Branch of Patapsco River, near Sykesville, Carroll County, MD)

Concrete Tee Beam - monolithic concrete deck and concrete girders acting compositely and supported on abutments/piers.



Concrete slab bridge (SHA Bridge No. 1611200, MD 381 over Norfolk Southern Railroad, Prince George's County, MD) -- the sections at the piers are haunched or deeper in order to accommodate the stress of the traffic on the deck above.



Concrete Encased Steel Beam, SHA Bridge No. 0205000, MD 176 over Piney Run, Anne Arundel County, MD



Concrete Rigid Frame (SHA Bridge No. 1010800, US 15 over Midland Railroad, Frederick County, MD)

Eligibility Explanation

Between 1948 and 1965, the Maryland State Roads Commission (SRC) built new highways and bridges under three construction programs: "The Five Year," "The Twelve Year," and "The Go Roads" Programs. The SRC's efforts to construct 3,452 miles of the state's primary, secondary and interstate road systems resulted in 557 new bridges on the highways. This large number of structures required the agency to streamline and economize by using standardized bridge elements, as well as other standardized highway components. In order for the SRC engineers and contractors to complete their tasks on schedule, the agency chose to design several different types of girder and beam bridges or reinforced concrete bridges because of their common appearance and function. Each of these bridge types had elements that could be prefabricated off-site, delivered to the construction site, and once the bridge piers were built, the metal bridge superstructure could be completed rapidly. The reinforced concrete bridges could be constructed in areas where there was no traffic passing through the construction site, but parts could also be prefabricated off-site and shipped to the site. For example, elements could be pretensioned prior to arriving on the construction site.

There were few aesthetic treatments for the 1948-1965 bridges, and the common design elements included the two-strand Alcoa aluminum railing or Bethlehem Steel railing attached to a concrete parapet, exposed, painted steel I- or H-beams and plate girders, piers with a square cap supported by round columns standing on a base. Another type of pier that was frequently used was the Monotube Bent Pile that are concrete filled fluted metal columns attached to the pier caps to support the bridge's superstructure. The smaller metal and concrete elements were generally prefabricated and delivered to the job site. The bridge design plans contain drawings that show the standard designs for the parapets and railings, and specify that either the Alcoa or Bethlehem Steel types would be acceptable. The metal beams and girders also could be ordered by length and weight depending on the bridge design requirements (length and width of bridge, traffic volumes, crossing type). Unlike the bridges from the 1930s, the new bridge parapets were higher and



Tee Beam (SHA Bridge No. 1000600, MD 806A over High Run, Frederick County, MD)



Two-strand aluminum railing and concrete parapet

closed so that drivers would be less distracted by looking through the parapets at the scenery beyond the bridge.

However, since 1965, many of these bridges have also been altered by widening or redecking with new parapets. In the 1980s, many bridges had the parapet endposts replaced with trapezoidal shapes to increase driver safety at the approaches to the bridges. Another change was to add safety fencing across the bridges. The SRC made all of these changes in response to growing traffic and concern for driver safety on the associated highways. These types of alterations preclude these bridges from being able to convey their significance as mid-twentieth century bridges.

By the 1950s, standardization was not a new innovation and did not result in a markedly different bridge design from those bridges built in the 1930s. The SRC began to use Standard Plans for its bridge designs in 1912 with plans for concrete slab and metal girder bridges. By the 1930s and early 1940s, the SRC did not rely on the earlier Standard Plans, but began using standardized bridge elements to design and construct rolled and plate girder bridges for crossings that did not require a specialized solution. One change from the 1930s was that the bridges were no longer encased in concrete. Instead, the metal

beams would be exposed but painted. Not using additional concrete enabled the SRC to further reduced the cost of bridge construction. In the case of concrete bridges, the SRC continued using reinforced concrete to design and construct slab, beams, girders and rigid frame bridges for crossings that did not require a specialized solution. These bridges were less expensive to construct because they were not the decorative arched bridges that were frequently built during the early part of the twentieth century. Prestressed concrete bridges were first built during the 1948-1965 period, but not universally incorporated into all concrete bridges on the state system.

Bridge building was one of the most expensive undertakings for the transportation agency, and standardizing as much of the process helped to control the costs and construction time. Through the post-war period, SRC continued its earlier practices from the 1930s and 1940, building plate and rolled girders and reinforced concrete bridges that enabled the agency to produce similar designs for many new crossings. The large number of similar bridges demonstrates how the SRC made practical use of standardization to build the new highway system.

The mid-century bridges were not constructed as the single most important element of the highway system, nor were they unusual designs. Rather, the bridges were constructed as an integral part of the associated highway, and there were many bridges on each highway that crossed other roads, railroads, and bodies of water along the route. Although the SRC constructed many bridges and highways during this period, that is not an exceptional event.

During this same period, other state Departments of Transportation such as Delaware, New Jersey, Virginia, Nebraska, Tennessee, Oregon and California were constructing similar bridges and highways in order to keep up with growing traffic on state highways. The steel beam and girder bridges and reinforced concrete bridges constructed during this period by the SRC became a common resource found on every highway in the state and in many other states as well.

Based on the foregoing information, SHA has determined that the bridges constructed between 1948 and 1965 are not eligible for inclusion in the National Register of Historic Places under Criteria A (events), B (people), or C (engineering). This determination is made because the highways and bridges constructed between 1948 and 1965 have frequently been widened or altered, and those bridges and highways which have not been altered do not retain the ability to convey significance of the road building events that occurred during this time.

Eligible Bridges

The following bridges have been determined eligible by SHA and MHT has concurred with the eligibility determinations. Information about bridges that the agencies have agreed are not eligible is included in Appendix A.

MD 942 over the Potomac River, SHA Bridge No. 0106600 – Double thru arch bridge constructed in 1954, in Cumberland, Allegany County. Determined eligible in 2001 and a Preservation Priority Bridge.

MD 151 over Patapsco and Back River Railroad and MD 151B, SHA Bridge No. 0309900 – Steel stringer/multi-beam or girder bridge – described as a metal girder bridge in the DOE form SHA prepared in 2002. The bridge was designed and constructed by the Bethlehem Steel Bridge Company and given to the SRC once MD 151 was constructed. The bridge stands at the entrance of the Bethlehem Steel Plant in Sparrows Point, Baltimore County.

MD 231 over Patuxent River, SHA Bridge No. 0400800 –a movable swing bridge that was constructed in 1950/51 between Charles and Calvert Counties. Determined eligible in 1999.

Old MD 32 over River Road, South Branch of Patapsco River, B&ORR (now CSX), SHA Bridge No. 1304600 – A three-span semi-monocoque composite aluminum box beam bridge near Sykesville that was closed to traffic in 2004. Determined eligible in 2000 and a Preservation Priority Bridge, because it is one of six aluminum bridges in the United States.

MD 32 over Liberty Reservoir, SHA Bridge No. 0604900 – a steel deck truss constructed as part of the Liberty Reservoir construction in 1952. Determined eligible in 2008 for its association with the Liberty Reservoir construction.

US 113 Business over Purnell Branch, SHA Bridge No. 2300800, a three-span concrete slab bridge with decorative metal railings, constructed in 1952 and determined eligible in 2004.

Also recommended as eligible from the 1948-1965 period are several bridges investigated by URS and Hard Lines Design in 2003 and 2004:

MD 144 over the Monocacy River, SHA Bridge No. 1003803, MIHP No. F-3-205, a three span steel deck Warren truss bridge built in 1955 and altered in 1987 by the replacement of its deck and parapets as well as repairs to several stringers in the deck truss.

MD 18B over Kent Narrows, SHA Bridge No. 1700600, MIHP No. QA-542, a twelve-span steel beam and bascule bridge, built in 1952 as part of the new Chesapeake Bay Bridge and US 50 improvements in Queen Anne's County.

Appendix C: Highway and Bridge Terms and Definitions

Annual Average Daily Traffic (AADT) - The total volume passing a point or segment of a highway facility in both directions for one year, divided by the number of days in the year.



Abutment - A retaining wall supporting the ends of a bridge or viaduct.

American Association of State Highway and Transportation Officials (AASHTO) -

AASHTO is a nonprofit, nonpartisan association representing highway and transportation departments. Its guides and specifications are used to describe loading requirements for highway (vehicular) bridges. Formerly known as American Association of State Highway Officials (AASHO)

Anchor Span - Located at the outermost end, it counterbalances the arm of a span extending in the opposite direction from a major point of support. Often attached to an abutment.

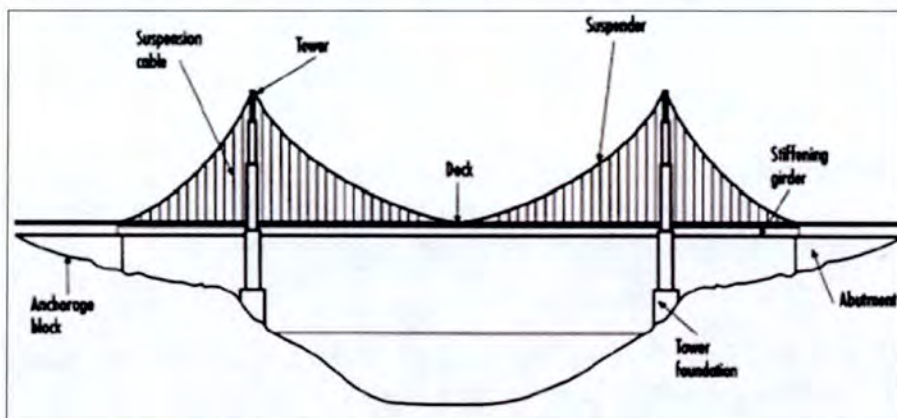

Anchorage Block -

Located at the outermost ends, the part of a suspension bridge to which the cables are attached. Similar in location to an abutment of a beam bridge.

Approach - The part of the bridge that carries traffic from the land to the main parts of the bridge.

Approach Span - The span or spans connecting the abutment with the main span or spans.

Aqueduct - A pipe or channel, open or enclosed, that carries water. May also be used as part of a canal to carry boats. Sometimes carried by a bridge.

Arch - A typically curved structural member spanning an opening and serving as a support.



Arch Bridge - A bridge whose main support structure is an arch. Additionally, the bridge may be termed a through arch, which is simply one where the roadway appears to go through the arch.

Arch Barrel - The inner surface of an arch extending the full width of the structure.

Awards - Projects authorized to proceed with construction after bids have been received and accepted by the authorizing transportation agency.



Bascule Bridge - From the French word for “see-saw,” a bascule bridge features a movable span (leaf) that rotates on a horizontal hinged axis (trunnion) to raise one end vertically. A large counterweight is used to offset the weight of the raised leaf. May have a single raising leaf or two that meet in the center when closed.

Beam - A horizontal structure member supporting vertical loads by resisting bending. A girder is a larger beam, especially when made of multiple plates. Deeper, longer members are created by using trusses.

Beam Bridge - A bridge built of beams, either classified as a short-span or long-span beam bridge, which is supported on beams whose ends rest on piers or abutments.

Bearing - A device at the ends of beams that is placed on top of a pier or abutment. The ends of the beam rest on the bearing.

Bedrock - The solid rock layer beneath sand or silt.

Bed Timbers - Timber components typically located between the top of an abutment or pier and the underside of the truss bottom chord. Intended to serve as sacrificial components they are easily replaced when deteriorated from rot, thus protecting truss components from similar deterioration.

Bent - Part of a bridge substructure. A rigid frame commonly made of reinforced concrete or steel that supports a vertical load and is placed transverse to the length of a structure. Bents are commonly used to support beams and girders. An end bent is the supporting frame forming part of an abutment.

Each vertical member of a bent may be called a column, pier or pile. The horizontal member resting on top of the columns is a bent cap. The columns stand on top of some type of foundation or footer that is usually hidden below grade.

A bent commonly has at least two or more vertical supports. Another term used to describe a bent is capped pile pier. A support having a single column with bent cap is sometimes called a “hammerhead” pier.

Bid Opening - The opening of construction project bids from contractors conducted by the transportation agency.

Bowstring Truss - A truss having a curved top chord and straight bottom chord meeting at each end.



Box Girder Bridge - A box girder bridge is a bridge where the main beams comprise girders in the shape of a hollow box. The box girder normally comprises either prestressed concrete, structural steel, or a composite of steel and reinforced concrete. The box is typically rectangular or trapezoidal in cross-section. Box girder bridges are commonly used for highway flyovers and for modern elevated structures of light rail transport. Although normally the box girder bridge is a form of beam bridge, box girders may also be used on cable-stayed bridges and other forms.



Brace - A structural support or to strengthen and stiffen a structure to resist loads.

Brace-Ribbed Arch (Trussed Arch) - An arch with parallel chords connected by open webbing.

Bridge Condition Ratings - Through periodic safety inspections, data is collected on the condition of the primary components of a structure. Condition ratings, based on a scale of 0-9, are collected for the following components

of a bridge. A condition rating of 4 or less on one of the following item classifies a bridge as structurally deficient.

The bridge deck, including the wearing surface:

The superstructure, including all primary load-carrying members and connections

The substructure, considering the abutments and all piers

To be eligible for federal aid the following is necessary (a local match is required):

Replacement: bridge must have a sufficiency rating of less than 50 and be either functionally obsolete or structurally deficient.

Repair: bridge must have a sufficiency rating of less than 80 and the jurisdiction is prevented from using any additional federal aid for 10 years.

Cable - Part of a suspension bridge extending from an anchorage over the tops of the towers and down to the opposite anchorage. Suspenders or hangers are attached along its length to support the deck.

Cable-Stayed Bridge - A variation of suspension bridge in which the tension members extend from one or more towers at varying angles to carry the deck. Allowing much more freedom in design form, this type does not use cables draped over towers, nor the anchorages at each end, as in a traditional suspension bridge.

Caisson - "Caisson" is the French word for "box." A caisson is a huge box made of steel-reinforced and waterproof concrete with an open central core. At the base of the caisson is its "cutting edge" of plate steel. In a suspension bridge the caisson becomes the foundation, the pier, supporting for the bridge's towers.

Camber - A positive, upward curve built into a beam that compensates for some of the vertical load and anticipated deflection.

Camelback Truss - A truss having a curved top chord and straight bottom chord meeting at each end, especially when there are more than one used end to end.



Cantilever - A structural member that projects beyond a supporting column or wall and is counterbalanced and/or supported at only one end.

Cast-in-Place - Concrete poured within formwork on site to create a structural element in its final position.

Castellated Girder - A steel beam fabricated by making a zig zag cut along its web, then welding the two sides together at their peaks. This creates a beam that has increased depth and, therefore, greater strength, but is not increased in weight.



Catenary - Curve formed by a rope or chain hanging freely between two supports. The curved cables or chains used to support suspension bridges may be referred to as catenaries.

Catwalks - Temporary foot bridges, used by bridge workers to spin the main cables (several feet above each catwalk), and to attach the suspender cables that connect the main cables to the deck.

Centering - Temporary structure or falsework supporting an arch during construction.

Chord - Either of the two principal members of a truss extending from end to end, connected by web members.



Closed Spandrel Deck Arch - One of the oldest and strongest types of bridges, the arch has been used in bridge building since the Roman era. An arch supports weight by compression on an axis or keystone. The axis or keystone transfers the stress of gravity (the traffic load) outward toward the base of the arch. Supports called abutments absorb the pressure and stop the ends of the bridge from spreading apart. Most arch bridges have vertical supports called spandrels that distribute the weight on the deck to the arch below.

The first arch bridges were built of stone but now are constructed of concrete or steel for greater strength and durability. Arch bridges are strong because the entire structure is under compression. Therefore, they must be built of materials that are strong under compression. Putting more weight on the arch actually compresses the material and makes the structure more rigid. Most arch bridges span between 200-800 feet.

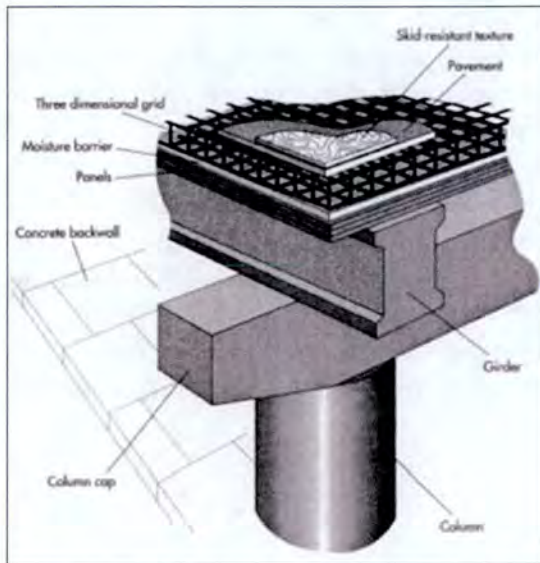

Column - A vertical, structural element, strong in compression.

Column Cross Brace - Transverse brace between two main longitudinal members.

Compression Member - An engineering term that describes a timber or other truss member that is subjected to squeezing or pushing. Also see tension member.

Condition Ratings - According to the National Bridge Inspection Standards (NBIS), condition ratings are used to describe an existing bridge or culvert compared with its condition if it were new. The ratings are based on the materials, physical condition of the

deck (riding surface), the superstructure (supports immediately beneath the driving surface), and the substructures (foundation and supporting posts and piers). General condition ratings range from 0 (failed condition) to 9 (excellent).

Continuous Span Beam Bridge - A simple bridge made by linking one beam bridge to another; some of the longest bridges in the world are continuous span beam bridges.

Crown - On road surfaces, where the center is the highest point and the surface slopes downward in opposite directions, assisting in drainage. Also a point at the top of an arch.



Culvert - A drain, pipe or channel that allows water to pass under a road, railroad or embankment.

Damping - The action of reducing the vibration of an object. This tends to return the vibrating object to its original position.

Dead Load - The static load imposed by the weight of materials that make up the bridge structure itself.

Debarment - Legally preventing a company or person from participation in bid lettings or construction proceedings.



Deck - The roadway portion of a bridge, including shoulders. Most bridge decks are constructed as reinforced concrete slabs, but timber decks are still seen in rural areas and open-grid steel decks are used in some movable bridge designs.

Deck Bridge - A bridge in which the supporting members are all beneath the roadway.



[Deck Plate Girder](#) - A plate girder bridge is a bridge supported by two or more plate girders. The plate girders are typically I-beams made up from separate structural steel plates (rather than rolled as a single cross-section), which are welded (or occasionally bolted or riveted) together to form the vertical web and horizontal flanges of the beam. In some cases, the plate girders may be formed in a Z-shape rather than I-shape.

Plate girder bridges are suitable for short to medium spans and may support railroads, highways or other traffic.

In the deck-type bridge, a steel or reinforced concrete bridge deck is supported on top of two or more plate girders, and may act compositely with them. Additional beams may span across between the main girders, for example in the form of bridge known as ladder-deck construction. Also, further elements may be attached to provide cross-bracing and prevent the girders from buckling.

[Deck Truss](#) - bridge whose roadway is supported from beneath by a truss.



[Deck Truss Cantilever Bridge](#) - A cantilever bridge is a bridge built using cantilevers: structures that project horizontally into space, supported on only one end. For small footbridges, the cantilevers may be simple beams; however, large cantilever bridges designed to handle road or rail traffic use trusses built from structural steel, or box girders built from prestressed concrete. A simple cantilever span is formed by two cantilever arms extending from opposite sides of the obstacle to be crossed, meeting at the center. In a common variant, the suspended span, the cantilever arms do not meet in the center; instead, they support a central truss bridge which rests on the ends of the cantilever arms.

[Deflection](#) - The displacement of a structural member or system under load.

[Diaphragm](#) - Bracing that spans between the main beams or girders of a bridge or viaduct and assists in the distribution of loads.

[Diagonal](#) - A sloping structural member of a truss or bracing system.

[Diversion Channel](#) - A bypass created to divert water around a structure so that construction can take place.

[Downstream Face](#) - The side of the bridge that is not against the water.

[Embankment](#) - Angled grading of the ground.

[End Post](#) - The outward most vertical or angled compression member of a truss.

[Environmental Impact Statement \(EIS\)](#) - A comprehensive study of potential social, economic and environmental impacts related to a federally-assisted project. Projects for which an EIS is required are defined in the National Environmental Policy Act of 1969, as amended.



[Expansion Joint](#) - A meeting point between two parts of a structure that is designed to allow for movement of the parts due to thermal or moisture factors while protecting the parts from damage. Commonly visible on a bridge deck as a hinged or movable connection.

[Extrados](#) - The outer exposed curve of an arch; defines the lower arc of a spandrel.

[Eye Bar](#) - A structural member having a long body and an enlarged head at each end. Each head has a hole through which a pin is inserted to connect to other members.

[Fatigue](#) - Cause of structural deficiencies, usually due to repetitive loading over time.

[Federal Fiscal Year](#) - October 1 through September 30 of the following year.

[Federal Highway Administration \(FHWA\)](#) - The mission of FHWA is to administer the Federal-Aid Highway Program to create the best transportation system in the world for the American people through proactive leadership, innovation, and excellence in service. The FHWA is a part of the United States Department of Transportation and is headquartered in Washington, D.C., with field offices located across the United States.

[Fill](#) - Earth, stone or other material used to raise the ground level, form an embankment or fill the inside of an abutment, pier or closed spandrel.

[Fixed Arch](#) - A structure anchored in its position. Compare to hinged arch.

[Fixed-span Bridge](#) - A bridge without a movable, or draw, span.

[Floorbeam](#) - Horizontal members that are placed transversely to the major beams, girders or trusses; used to support the deck.

[Flutter](#) - Self-induced harmonic motion. A self-excited aerodynamic instability that can grow to very large amplitudes of vibrations.

[Flyover](#) - A bridge formed when one roadway crosses over another at a higher level; an overpass.

[Footing](#) - The enlarged lower portion of the substructure or foundation that rests directly on the soil, bedrock or piles; usually below grade and not visible.

[Force](#) - Any action that tends to maintain or alter the position of a structure.

Forms - Temporary structures or molds made of wood, metal, or plastic used when placing concrete to ensure that it is shaped to its desired final form.

Formwork - A total system of support for freshly placed concrete, including the mold and all supporting members, hardware, and necessary bracing. Formwork must be strong enough to support the considerable weight and pressure of wet concrete without bending or breaking.

Fracture-Critical - A fracture-critical bridge is one that does not contain redundant supporting elements. This means that if those key supports fail, the bridge would be in danger of collapse. This does not mean the bridge is inherently unsafe, only that there is a lack of redundancy in its design.

Full-Depth Replacement of Concrete Deck - A technique used to restore the structural integrity and rideability of distressed concrete pavement. It involves removing the deteriorated concrete down to the base, repairing the base, and refilling the excavated area with new concrete. Full-depth replacement is a particularly effective technique for pavement repairs near joints and cracks. By removing and replacing isolated areas of deterioration, pavement can be restored close to its original condition.

Functionally Obsolete - A functionally obsolete bridge is one that was built to standards that are not used today. These bridges are not automatically rated as structurally deficient, nor are they inherently unsafe. Functionally obsolete bridges are those that do not have adequate lane widths, shoulder widths, or vertical clearances to serve current traffic demand, or those that may be occasionally flooded.

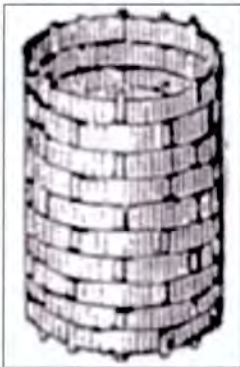

A functionally obsolete bridge is similar to an older house. A house built in 1950 might be perfectly acceptable to live in, but it does not meet all of today's building codes. Yet, when it comes time to consider upgrading that house or making improvements, the owner must look at ways to bring the structure up to current standards.

Gabion - A galvanized wire box filled with stones used to form an abutment or retaining wall.

Girder - A horizontal structure member supporting vertical loads by resisting bending. A girder is a larger beam, especially when made of multiple metal plates. The plates are usually riveted or welded together.



Girder Bridge - A girder bridge is perhaps the most common and most basic bridge. The cross section of the girder takes the shape of the capital letter "I". The vertical plate in the middle is known as the web, and the top and bottom plates are referred to as flanges. A box girder is much the same as an I-beam girder except it takes the shape of a box. The typical box girder has two webs and two flanges. However, in some cases there are more than two webs, creating a multiple chamber box girder. Other examples of simple girders include pi girders, named for their likeness to the mathematical symbol for pi, and T shaped girders.



Glu-lam Freespan - Glu-lam bridges can freespan over 100 feet. This makes a Glu-lam freespan the ideal choice for road overpasses, bridging steep ravines and creating a crossing where pile foundations would be prohibited.

Gross Vehicle Weight (GVW) - Refers to the total curb weight of the vehicle and payload. Expresses the maximum continuous load for vehicles traversing a bridge.

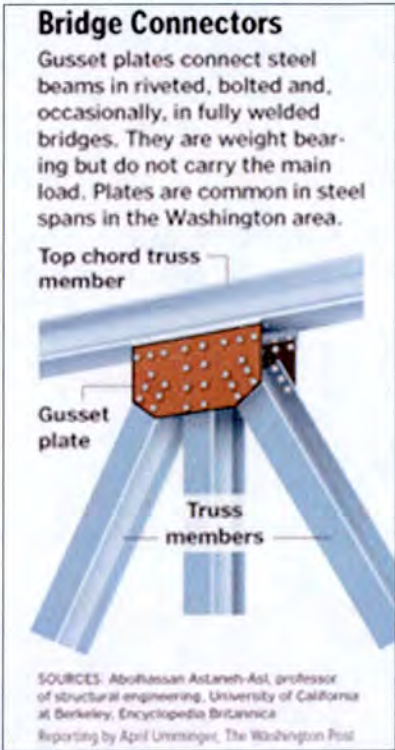

Gusset Plate - A metal plate used to unite multiple structural members of a truss.

Hanger - A tension member serving to suspend an attached member.

Haunch - The enlarged part of a beam near its supported ends that results in increased strength; visible as the curved or angled bottom edge of a beam.



Haunched Girder - Typical slab-on-beam bridges have space between the bottom of the slab and the top of the top flanges of beams. This space, referred to as the fillet or haunch, typically consists of unreinforced concrete that increases the dead load of the section but is not normally considered to add strength.



Headwall - The device placed at the end of a bridge that comprises a large portion of the abutment. Headwalls are used to retain the road formation soil around and above the abutments and prevent erosion at the abutment.

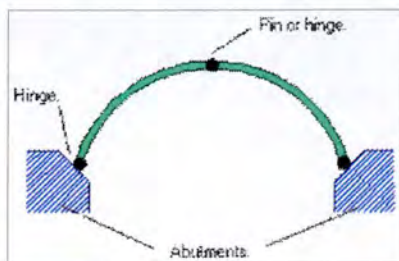

Hinged Arch - A two-hinged arch is supported by a pinned connection at each end. A three-hinged arch also includes a third pinned connection at the crown of the arch near the middle of a span. Compare to fixed arch.

Humpback - A description of the sideview of a bridge having relatively steep approach embankments leading to the bridge deck.

Impost - The surface that receives the vertical weight at the bottom of an arch.



Intrados - The interior arc of an arch.

Jersey Barrier - A low, reinforced concrete wall wider at the base, tapering vertically to near mid-height, then continuing straight up to its top. The shape is designed to direct automotive traffic back toward its own lane of travel and prevent crossing of a median or leaving the roadway. Commonly used on new and reconstructed bridges in place of decorative balustrades, railings or parapets.



Joint - A device connecting two or more adjacent parts of a structure. A roller joint allows adjacent parts to move controllably past one another. A rigid joint prevents adjacent parts from moving or rotating past one another.

Keystone - The uppermost wedge-shaped voussoir at the crown of an arch that locks the other voussoirs into place.

Knee Brace - Additional support connecting the deck with the main beam that keeps the beam from buckling outward. Commonly made from plates and angles.

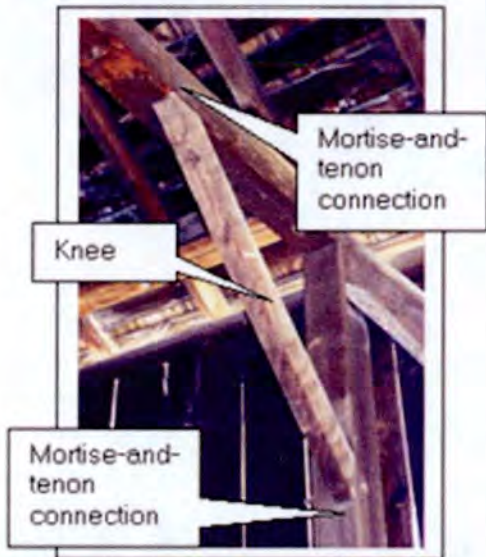

Lag - Crosspieces used to connect the ribs in centering.

Lateral Bracing - Members used to stabilize a structure by introducing diagonal connections.

Lattice - An assembly of smaller pieces arranged in a gridlike pattern; sometimes used a decorative element or to form a truss of primarily diagonal members.

Letting Date - The date bids are scheduled to be opened by the transportation agency.

Lift Span - The part of a movable-span (or drawbridge) that opens to allow river traffic. Also called the draw-span.

Live Load - Vehicular traffic, wind, water, and/or earthquakes.

Load - Weight distribution throughout a structure; loads caused by wind, earthquakes and gravity affect how weight is distributed throughout a structure.

Load Posted - Any bridge or structure restricted to carrying loads less than the legal load limit. Load posting a bridge is required by National Bridge Inspection Standards when a bridge is not capable of safely carrying a legal load.



Lower Chord - The bottom horizontal member of a truss.

Main Beam - A beam supporting the spans and bearing directly onto a column or wall.

Main Span - The longest span in a multi-span bridge and located between the bridge's main piers or towers (supports). Bridges typically compared using main-span lengths, which do not account for the length of the entire bridge or its approaches.

Member - An individual angle, beam plate or built piece intended to become an integral part of an assembled frame or structure.

Movable Bridge - A bridge in which the deck moves to clear a navigation channel; a swing bridge has a deck that rotates around a center point; a drawbridge has a deck that can be raised and lowered; a bascule bridge deck is raised with counterweights like a drawbridge; and the deck of a lift bridge is raised vertically like a massive elevator.

National Environmental Policy Act of 1969 (NEPA) - Legislation requiring that any project using federal funding or requiring federal approval (including transportation projects) examine the effects of alternative choices on the environment before a decision is made.

Obligation Authority - The maximum amount of federal formula funds that can be obligated or authorized in a federal fiscal year. The use of obligation authority does not affect the apportionment or allocation of federal funds a state receives. It only controls the rate of expenditure.



Open Spandrel Deck Arch - An arch bridge is based on the ancient concept of spanning an opening with a curved structural member. The arch transmits the load from the bridge deck to the abutments on both sides of the span and thus to the ground below. Early arch bridges were built of stone blocks wedged together to form the arch. Short modern arch bridges may use wood or concrete, while longer arch spans are built of steel. Since the arch requires no central support, it can be used to bridge long open spans. The arch can be either above or below the bridge deck. The arch pushes downward and outward against its abutments, which must be heavy to resist the thrust. Since the abutments transfer both horizontal and vertical forces from the bridge deck, arch bridges can only be used where the ground or foundation is solid and stable. The curved arch structure offers a high resistance to bending forces.

Arch bridges can be constructed with the deck above the arch (a deck arch bridge), or the deck can be hung from a segment of the arch which rises above the deck (a through arch or tied arch bridge). In a deck arch bridge, the space between the bottom of the arch and the deck can be solid (a closed spandrel deck arch) or open with supporting vertical members (an open spandrel deck arch).

Oscillation - A periodic movement back and forth between two extreme limits. An example is the string of a guitar that has been plucked. Its vibration back and forth is one oscillation. A vibration is described by its size (amplitude), its oscillation rate (frequency), and its timing (phase). In a suspension bridge, oscillation results from energy collected and stored by the bridge. If a part of the bridge has to store more energy than it is capable of storing, that part could fail.



Parabola - A form of arch defined by a moving point that remains equidistant from a fixed point inside the arch and a moving point along a line. This shape when inverted into an arch structure results in a form that allows equal vertical loading along its length.

Parapet - A low wall along the outside edge of a bridge deck used to protect vehicles and pedestrians.



Pier - A vertical structure that supports the ends of a multi-span superstructure at a location between abutments. Also see column and pile.

Pile - A long column driven deep into the ground to form part of a foundation or substructure. Also see column and pier.



Pile Bent - A row of driven or placed piles with a pile cap to hold them in their correct positions.

Pile Driver - A machine that repeatedly drops a heavy weight on top of a pile until the pile reaches solid soil or rock or cannot be pushed down any farther.



Pile-Supported Bridge - Pile-supported structures are supported by timber piling at regular intervals (typically 10 to 15 feet on center). A pile-supported structure can be built to any length and virtually any height.

Pin - A cylindrical bar that is used to connect various members of a truss; such as those inserted through the holes of a meeting pair of eyebars.

Pony Truss - A truss that carries its traffic near its top chord, but not low enough to allow crossbracing between the parallel top chords. Compare to deck truss and through truss.

Portal - The opening at the ends of a through truss with forms the entrance. Also the open entrance of a tunnel.

Post - One of the vertical compression members of a truss that is perpendicular to the bottom chord.

Pre-Cast Girder - Girder is fabricated off-site Portland cement using reinforcing steel and post-tensioning cables. These girders are shipped to the construction site by truck and hoisted into place by cranes.

Project Number - A specific number assigned to all federal, state and local projects. The funding source (prefix), functional classification, a sequential number and possible suffix compose the elements of a project number.

Public Hearing - Meeting held with purpose of receiving public comments on proposed projects.

Pylon - A monumental vertical structure marking the entrance to a bridge or forming part of a gateway.

Railing - A fence-like construction built at the outermost edge of the roadway or the sidewalk portion of a bridge to protect pedestrians and vehicles.

Range of Stress - The algebraic difference between the minimum and maximum stresses in a member.

Reaction - The resistance of a support against the pressure of a loaded member.

Redundancy - A structural condition where there are more elements of support than are necessary for stability.

Redundant Member - A member in a bridge that renders it a statically indeterminate structure; the structure would be stable without the redundant member whose primary purpose is to reduce the stresses carried by the determinate structure.

Reinforced Concrete - Concrete with steel bars or mesh embedded in it for increased strength in tension.

Reinforcement - Adding strength or bearing capacity to a structural member. Examples include the placing of metal rebar into forms before pouring concrete or attaching gusset plates at the intersection of multiple members of a truss.

Resonance - The regular vibration of an object as it responds in step (at the same frequency) with an external force.

Retractile Draw Bridge - A bridge with a superstructure designed to move horizontally either longitudinally or diagonally from "closed" to "open" position, the portion acting in cantilever being counterweighted by that supported on rollers; also known as traverse draw bridge.

Revet - The process of covering an embankment with stones.

Revetment - A facing of masonry or stones to protect an embankment from erosion.

Rib - Any one of the arched series of members that is parallel to the length of a bridge, especially those on a metal arch bridge.

Rigger - An individual who erects and maintains scaffolding or other inspection access equipment.

Rigid - Ability to resist deformation when subjected to a load.

Rigidity - The measure of a structure's ability not to change shape when subjected to a load.

Rigid Frame - A structural frame in which the members are connected together without hinges.

Rigid Frame Bridge - A type of girder bridge in which the piers and deck girder are fastened to form a single unit. Unlike typical girder bridges that are constructed so that the deck rests on bearings atop the piers, a rigid frame bridge acts as a unit. Pier design may vary.

Rigid Frame Pier - A pier with two or more columns and a horizontal beam on top constructed monolithically to act like a frame.

Rip Rap - Gabions, stones, blocks of concrete or other protective covering material of like nature deposited upon river and stream beds and banks, lake, tidal or other shores to prevent erosion and scour by water flow, wave or other movement .

Rivet - A metal fastener used in pre-1970 construction; made with a rounded preformed head at one end and installed hot into a predrilled or punched hole; the other end was hammered into a similar shaped head thereby clamping the adjoining parts together.

Riveted Connection - A rigid connection of metal bridge members that is assembled with rivets. Riveted connections increase the strength of the structure.

Riveted Joint - A joint in which the assembled members are fastened by rivets.

Rocker Bearing - A bridge support that accommodates expansion and contraction of the superstructure through a rocking action.

Rocker Bent - A bent hinged or otherwise articulated at one or both ends to provide the longitudinal movements resulting from temperature changes and superimposed loads.

Roller - A steel cylinder intended to provide longitudinal movements by rolling contact.

Roller Bearing - A single roller or a group of rollers so housed as to permit longitudinal movement of a structure.

Roller Nest - A group of steel cylinders used to facilitate the longitudinal movements resulting from temperature changes and superimposed loads.

Rolling Lift Bridge - A bridge of bascule type devised to roll backward and forward upon supporting girders when operated through an "open and closed" cycle.



Segmental Arch - An arch formed along an arc that is drawn from a point below its spring line, thus forming a less than semicircular arch. The intrados of a Roman arch follows an arc drawn from a point on its spring line, thus forming a semi-circle.

Shaft - A vertical, load bearing structure that uses end bearing and friction to support loads.

Shear - A force that causes parts of a material to slide past one another in opposite directions.

Shoefly - A temporary bridge taking the place of the main bridge while construction is completed on the main bridge.

Silt - Sediment particles ranging from 0.00016 to 0.0024 inches in diameter.

Simple Span - A span in which the effective length is the same as the length of the spanning structure. The spanning superstructure extends from one vertical support, abutment or pier to another without crossing over an intermediate support or creating a cantilever.

Skew - When the superstructure is not perpendicular to the substructure, a skew angle is created. The skew angle is the acute angle between the alignment of the superstructure and the alignment of the substructure.

Span - The horizontal space between two supports of a structure. Also refers to the structure itself. May be used as a noun or a verb.

The clear span is the space between the inside surfaces of piers or other vertical supports. The effective span is the distance between the centers of two supports.

Spandrel - The roughly triangular area above an arch and below a horizontal bridge deck. A closed spandrel encloses fill material. An open spandrel carries its load using interior walls or columns.

Specifications - A document that explains all material and construction requirements of the bridge structure to be constructed, usually used by engineers or architects in the planning stages of construction.

Splice Plate - A plate that joins two girders. Commonly riveted or bolted.

Springer - The first voussoir resting on the impost of an arch.

Smith Truss - Tipp City, Ohio, native Robert W. Smith received truss patents in 1867 and 1869.

Stanchion - One of the larger vertical posts supporting a railing. Smaller, closely spaced vertical supports are balusters.

STIP - Statewide Transportation Improvements Project (STIP)

Stay - Diagonal brace installed to minimize structural movement.

Steel Stringers - Load-carrying beams in the viaduct's superstructure that rest on abutments and other intermediate supports.

Stiff - Ability to resist deformation.

Stiffener - On plate girders, structural steel shapes, such as an angle, are attached to the web to add intermediate strength.

Stringer - A beam aligned with the length of a span which supports the deck.

Structurally Deficient and Sufficiency Rating - A bridge sufficiency rating includes a multitude of factors: inspection results of the structural condition of the bridge, traffic volumes, number of lanes, road widths, clearances, and importance for national security and public use, to name just a few.

The sufficiency rating is calculated per a formula defined in Federal Highway Administration's Recording and Coding Guide for the Structure Inventory and Appraisal of the Nation's Bridges. This rating is indicative of a bridge's sufficiency to remain in service. The formula places 55 percent value on the structural condition of the bridge, 30 percent on its serviceability and obsolescence, and 15 percent on its essentiality to public use.

The point calculation is based on a 0-100 scale and it compares the existing bridge to a new bridge designed to current engineering standards.

The bridge's sufficiency rating provides an overall measure of the bridge's condition and is used to determine eligibility for federal funds. Bridges are considered structurally deficient if significant load carrying elements are found to be in poor condition due to deterioration or the adequacy of the waterway opening provided by the bridge is determined to be extremely insufficient to point of causing intolerable traffic interruptions.

Every bridge constructed goes through a natural deterioration or aging process, although each bridge is unique in the way it ages.

The fact that a bridge is classified under the federal definition as "structurally deficient" does not imply that it is unsafe. A structurally deficient bridge, when left open to traffic, typically requires significant maintenance and repair to remain in service and eventual rehabilitation or replacement to address deficiencies. To remain in service, structurally deficient bridges are often posted with weight limits to restrict the gross weight of vehicles using the bridges to less than the maximum weight typically allowed by statute.

To be eligible for federal aid the following is necessary (a local match is required):

Replacement: bridge must have a sufficiency rating of less than 50 and be either functionally obsolete or structurally deficient.

Repair: bridge must have a sufficiency rating of less than 80 and the jurisdiction is prevented from using any additional federal aid for 10 years.

Strut - A compressive member.

Substructure - The substructure consists of all parts that support the superstructure.

The main components are:

Abutments or end-bents

Piers or interior bents

Footings

Piling

Superstructure - The superstructure consists of the components that actually span the obstacle the bridge is intended to cross. It includes:

Bridge deck,

Structural members

Parapets, handrails, sidewalk, lighting and drainage features

Suspension - Legally halting a company or individuals ability to bid or participate in construction proceedings for a defined period of time.

Suspended Span - A simple beam supported by cantilevers of adjacent spans, commonly connected by pins.

Suspenders - Tension members of a suspension bridge which hang from the main cable to support the deck. Also similar tension members of an arch bridge which features a suspended deck. Also called hangers.



Suspension Bridge - A bridge which carries its deck with many tension members attached to cables draped over tower piers.

Swing Bridge - A movable deck bridge that opens by rotating horizontally on an axis. Compare to bascule bridge and vertical lift bridge.

Tension - A stretching force that pulls on a material.

Tension Member - Any timber or rod of a truss that is subjected to pull or stretch.

Through Truss - A truss that carries its traffic through the interior of the structure with crossbracing between the parallel top and bottom chords. Compare to deck truss and pony truss.

Tie - A tension member of a truss.



Tied Arch - An arch that has a tension member across its base connecting one end to the other.

Timber Freespan - Timber freespan bridges can freespan up to 26 feet. A timber freespan is generally used to span a creek or other relatively small crossings.

Torsion - An action that twists a material.

Tower - A tall pier or frame supporting the cable of a suspension bridge.

Trestle - A bridge structure consisting of spans supported upon frame bents.

Truss - In addition to classifying metal truss bridges by name, their form is further distinguished by the location of the bridge deck in relation to the top and bottom chords, and by their structural behavior.

In a deck configuration, traffic travels on top of the main structure; in a pony configuration traffic travels between parallel superstructures, which are not cross-braced at the top; in a through configuration, traffic travels through the superstructure (usually a truss), which is cross-braced above and below traffic.



Trussed Arch - A metal arch bridge that features a curved truss.

Two-Hinged Arch and Three-Hinged Arches - Arches use a curved structure that provides a high resistance to bending forces. Unlike girder and truss bridges, both ends of an arch are fixed in the horizontal direction (i.e., no horizontal movement is allowed in the bearing). Thus when a load is placed on the bridge (e.g., a car passes over it) horizontal forces occur in the bearings of the arch. These horizontal forces are unique to the arch and as a result arches can only be used where the ground or foundation is solid and stable.

Like the truss, the roadway may pass over or through an arch or in some cases both. Structurally, there are four basic arch types: hinge-less, two-hinged, three hinged, and tied arches.

The three-hinged arch adds an additional hinge at the top or crown of the arch. The three-hinged arch suffers very little if there is movement in either foundation (due to earthquakes, sinking, etc.) However, the three-hinged arch experiences much more deflection and the hinges are complex and can be difficult to fabricate. The three-hinged arch is rarely used anymore.

U-Bolt - A bar bent in the shape of the letter "U" and fitted with threads and nuts at its ends.

Ultimate Strength - The highest stress that a material can withstand before breaking.

Ultrasonic Testing - Nondestructive testing of a material's integrity using sound waves.

Underpass - The lowest feature of a grade separated crossing.

Uniform Load - A constant load across a member.

Unit Stress - The stress per unit of surface or cross-sectional area.

Uplift - A negative reaction or a force tending to lift a beam, truss, pile, or any other bridge element upwards.

Upper Chord - Top chord of a truss.

Upstream Face - The side of a bridge that is against the water.

Vault - An enclosing structure formed by building a series of adjacent arches.

Vertical Curve - A sag or crest in the profile of a roadway.

Vertical Lift Bridge - A movable deck bridge in which the deck may be raised vertically by synchronized machinery at each end.

Viaduct - A long, multi-span structure, especially one constructed of concrete. More commonly used in relation to structures carrying motor vehicles. Trestle is the term for a similar structure when used in relation to railroads.

Void - An empty or unfilled space in concrete.

Voussoir - Any one of the wedge shaped block used to form an arch.

Voussoir Arch - An arrangement of wedge shaped blocks set to form an arched bridge.

Waterway - The available width for the passage of water beneath a bridge.

Wearing Surface - The topmost layer of material applied upon a roadway to receive the traffic loads and to resist the resulting disintegrating action; also known as wearing course.

Web - The system of members connecting the top and bottom chords of a truss. Or the vertical portion of an I-beam or girder.

Web Members - The intermediate members of a truss, not including the end posts, usually vertical or inclined.

Web Plate - The plate forming the web element of a plate girder, built-up beam or column.

Web Stiffener - A small member welded to a beam web to prevent buckling of the web.

Weephole - A hole in a concrete retaining wall to provide drainage of the water in the retained soil.

Weigh in Motion (WIM) - Equipment that measures the weight of moving trucks. Is used by state highway agencies for monitoring pavement loadings.

Weld - A joint between pieces of metal at faces that have been made plastic by heat or pressure.



[Welded Bridge Structure](#) - A structure whose metal elements are connected by welds.

[Welded Joint](#) - A joint in which the assembled elements and members are united through fusion of metal.

[Wheel Guard](#) - A raised curb along the outside edge of traffic lanes to safeguard constructions outside the roadway limit from collision with vehicles.

[Wheel Load](#) - The load carried by and transmitted to the supporting structure by one wheel of a traffic vehicle, a movable bridge or other motive equipment or device.

[Wichert Truss](#) - The Wichert Truss, designed by E.M. Wichert of Pittsburg, PA, in 1930, is a cantilever spandrel-braced deck arch that is not a “true arch” bridge. The curved lower chord gives the bridge the form of an arch, but it does not rely on arch action to carry the load. The open diamond panel above each pier is the easily recognized mark of this truss type; without a vertical truss member in this hinged location.

[Wire Rope](#) - Steel cable.

[Working Stress](#) - The unit stress in a member under service or design load.

[X-Bracing](#) - A form of additional supports for the piling of a bridge. The timbers are placed in a “criss-cross” pattern joining the supporting piling.

[Yield](#) - Permanent deformation that a metal piece takes when it is stressed beyond the elastic limit.

[Yield Stress](#) - The stress at which noticeable, suddenly increased deformation occurs under slowly increasing load.

References:

CALTRANS | Caltech | Historic Bridges of Iowa | Indiana DOT | Texas DOT
Bridge Design Manual | Washington State DOT Tacoma Narrows Bridge Glossary
University of Iowa Libraries Lichtenberger Engineering Library Glossary
Source: <http://www.dot.state.oh.us/DIVISIONS/COMMUNICATIONS/BRIDGINGTHEGAP/Pages/BridgeTermDefinitions.aspx> downloaded 4/14/2010. Used with permission.

Appendix D: SHA Bridges Included in 1948-1965 Historic Highway Bridge Study

Eligibility	Description	Bridge No.	Year Built	County	Material	Type
	MD 36 over BRADDOCK RUN	0100100	1957	Allegany	Steel	Stringer/Multi-beam or Girder
	MD 36 over JENNINGS RUN	0100400	1957	Allegany	Steel	Stringer/Multi-beam or Girder
	US 40 ALT over BRADDOCK RUN	0102700	1948	Allegany	Concrete	Rigid Frame
	MD 144 over TOWN CREEK	0103400	1957	Allegany	Steel Continuous	Stringer/Multi-beam or Girder
	MD 51 over EVITTS CREEK	0104400	1957	Allegany	Prestressed (Pretensioned) Concrete	Box Beam or Girders - Multiple
	VICTORY POST DRIVE over GEORGES CREEK	0105500	1950	Allegany	Steel	Girder and Floorbeam System
	US 220 over MD 135A	0105900	1952	Allegany	Steel Continuous	Stringer/Multi-beam or Girder
NE	US 220 over N POTOMAC RIVER, MD 135	0106000	1951	Allegany	Steel Continuous	Stringer/Multi-beam or Girder
E	MD 942 over N BRANCH POTOMAC RIVER	0106600	1953	Allegany	Steel	Arch - Through
	MD 36 over NORTH BRANCH	0107800	1960	Allegany	Steel	Stringer/Multi-beam or Girder
	WINDY RIDGE DRIVE over JENNINGS RUN	0107900	1959	Allegany	Steel	Stringer/Multi-beam or Girder
	MD 952 over IS 68	0108100	1962	Allegany	Steel Continuous	Stringer/Multi-beam or Girder
	MD 135 over GEORGES CREEK	0108200	1963	Allegany	Steel	Stringer/Multi-beam or Girder
	MD 51 over CSX TRANS., WINEOW ST	0109200	1965	Allegany	Steel	Stringer/Multi-beam or Girder
	MD 2 RAMP '8' over BOULTERS WAY	0200800	1953	Anne Arundel	Steel Continuous	Stringer/Multi-beam or Girder
	US 50 RAMP '6' over BOULTERS WAY	0200900	1953	Anne Arundel	Steel Continuous	Stringer/Multi-beam or Girder
	MD 295 NBR over PATAPSCO RIVER	0201101	1949	Anne Arundel	Steel	Stringer/Multi-beam or Girder
	MD 295 SBR over PATAPSCO RIVER	0201102	1949	Anne Arundel	Steel	Stringer/Multi-beam or Girder
NE	MD 168 over MD 295 NBR	0201200	1949	Anne Arundel	Steel	Stringer/Multi-beam or Girder
NE	HAMMONDS FERRY RD over MD 295 NBR	0201300	1949	Anne Arundel	Steel	Stringer/Multi-beam or Girder
	WEST NURSERY ROAD over MD 295 NBR	0201400	1949	Anne Arundel	Steel	Stringer/Multi-beam or Girder

Eligibility	Description	Bridge No.	Year Built	County	Material	Type
NE	MD 295 NBR over AMTRAK, STONY RUN	0201801	1950	Anne Arundel	Steel	Stringer/Multi-beam or Girder
NE	MD 295 SBR over AMTRAK, STONY RUN	0201802	1950	Anne Arundel	Steel	Stringer/Multi-beam or Girder
NE	RIDGE ROAD over MD 295 NBR	0201900	1950	Anne Arundel	Steel	Stringer/Multi-beam or Girder
NE	MD 295 NBR over HANOVER ROAD	0202001	1950	Anne Arundel	Concrete	Rigid Frame
NE	MD 295 SBR over HANOVER ROAD	0202002	1950	Anne Arundel	Concrete	Rigid Frame
NE	MD 175 over MD 295	0202300	1952	Anne Arundel	Steel	Stringer/Multi-beam or Girder
	US 50 over PATUXENT RIVER	0202600	1951	Anne Arundel	Steel Continuous	Stringer/Multi-beam or Girder
	US 50 over PATUXENT RIVER ROAD	0202700	1950	Anne Arundel	Steel	Stringer/Multi-beam or Girder
	US 50 over RUTLAND ROAD	0202900	1950	Anne Arundel	Steel	Stringer/Multi-beam or Girder
	US 50 over SOUTH RIVER	0203000	1950	Anne Arundel	Steel	Stringer/Multi-beam or Girder
	US 50 over SOUTH HAVEN ROAD	0203100	1950	Anne Arundel	Steel	Stringer/Multi-beam or Girder
	US 50 over ADMIRAL DRIVE	0203400	1953	Anne Arundel	Steel Continuous	Stringer/Multi-beam or Girder
	US 50 over WEEMS CREEK	0203500	1953	Anne Arundel	Steel	Stringer/Multi-beam or Girder
	US 50 over SEVERN RIVER	0203800	1953	Anne Arundel	Steel	Stringer/Multi-beam or Girder
	US 50 over Boulders Way	0203900	1953	Anne Arundel	Steel Continuous	Stringer/Multi-beam or Girder
NE	MD 70 over Weems Creek	0204200	1953	Anne Arundel	Steel	Stringer/Multi-beam or Girder
NE	MD 70 over College Creek	0204300	1954	Anne Arundel	Steel	Stringer/Multi-beam or Girder
NE	MD 103 over Branch Of Deep Run	0204900	1949	Anne Arundel	Concrete	Tee Beam
NE	MD 176 over Piney Run	0205000	1949	Anne Arundel	Steel	Concrete Encased Steel Beam
	Hammonds Ferry Rd over Patapsco River	0207700	1961	Anne Arundel	Steel	Stringer/Multi-beam or Girder
	MD 258 over MD 4	0207800	1961	Anne Arundel	Steel	Stringer/Multi-beam or Girder
	MD 258 over Rockhold Creek	0207900	1963	Anne Arundel	Steel	Stringer/Multi-beam or Girder

Eligibility	Description	Bridge No.	Year Built	County	Material	Type
	MD 100 Ramp over MD 100 EBR	0208000	1963	Anne Arundel	Steel	Stringer/Multi-beam or Girder
	MD 100 EBR over MD 2	0208203	1963	Anne Arundel	Steel	Stringer/Multi-beam or Girder
	MD 100 WBR over MD 2	0208204	1963	Anne Arundel	Steel	Stringer/Multi-beam or Girder
	MD 100 EBR over MD 174	0208303	1963	Anne Arundel	Steel	Stringer/Multi-beam or Girder
	MD 100 WBR over MD 174	0208304	1963	Anne Arundel	Steel	Stringer/Multi-beam or Girder
	MD 100 EBR over MD 3 BUS	0208403	1963	Anne Arundel	Steel	Stringer/Multi-beam or Girder
	MD 100 EBR over MD 3 BUS	0208404	1963	Anne Arundel	Steel	Stringer/Multi-beam or Girder
	MD 100 EBR over OAKWOOD ROAD	0208503	1963	Anne Arundel	Steel	Stringer/Multi-beam or Girder
	MD 100 WBR over OAKWOOD ROAD	0208504	1963	Anne Arundel	Steel	Stringer/Multi-beam or Girder
	MD 2 RAMP 'K' over US 50	0210000	1953	Anne Arundel	Steel	Girder and Floorbeam System
	US 50 over MD 2, MD 450	0210100	1953	Anne Arundel	Steel	Stringer/Multi-beam or Girder
NE	Hammonds Ferry Rd over MD 295 SBR	0221600	1949	Anne Arundel	Steel	Stringer/Multi-beam or Girder
	West Nursery Road over MD 295 SBR	0221700	1949	Anne Arundel	Steel	Stringer/Multi-beam or Girder
	Ridge Road over MD 295 SBR	0221800	1950	Anne Arundel	Steel	Stringer/Multi-beam or Girder
NE	MD 168 over MD 295 SBR	0221900	1949	Anne Arundel	Steel	Stringer/Multi-beam or Girder
NE	US 1 over Herbert Run	0300700	1949	Baltimore	Steel	Stringer/Multi-beam or Girder
	MD 295 over Daisy Avenue	0301800	1949	Baltimore	Steel	Stringer/Multi-beam or Girder
	MD 25 over Western Run	0302300	1952	Baltimore	Steel	Stringer/Multi-beam or Girder
	MD 26 over Gwynns Falls	0303000	1965	Baltimore	Steel	Stringer/Multi-beam or Girder
NE	MD 137 over IS 83	0305000	1955	Baltimore	Steel	Stringer/Multi-beam or Girder
E	MD 151 over Patapsco & BACK River Railroad, MD 151B	0309900	1954	Baltimore	Steel	Stringer/Multi-beam or Girder
	Hollins Ferry Road over IS 695	0311000	1957	Baltimore	Steel	Stringer/Multi-beam or Girder
	US 1 ALT over IS 695	0311200	1957	Baltimore	Steel	Stringer/Multi-beam or Girder

Eligibility	Description	Bridge No.	Year Built	County	Material	Type
NE	MD 144 over IS 695	0312100	1957	Baltimore	Steel	Stringer/Multi-beam or Girder
	MD 129 over IS 695	0314700	1961	Baltimore	Steel	Stringer/Multi-beam or Girder
	MD 147 over IS 695	0317000	1961	Baltimore	Steel	Stringer/Multi-beam or Girder
	Putty Hill Road over IS 695	0317400	1961	Baltimore	Steel	Stringer/Multi-beam or Girder
	Lillian Holt Drive over IS 695	0317600	1961	Baltimore	Steel	Stringer/Multi-beam or Girder
	MD 7 over MD 695	0319000	1958	Baltimore	Steel	Stringer/Multi-beam or Girder
	MD 43 & Ramp N over CSX TRANSPORTATION	0321704	1963	Baltimore	Steel	Stringer/Multi-beam or Girder
	MD 7 over MD 43	0321800	1963	Baltimore	Steel	Stringer/Multi-beam or Girder
	MD 157 over MD 158 WBR	0334900	1957	Baltimore	Steel	Stringer/Multi-beam or Girder
	MD 151B over MD 151	0335000	1957	Baltimore	Steel	Stringer/Multi-beam or Girder
E	MD 151B over Patapsco & Back River Railroad	0335100	1957	Baltimore	Steel	Stringer/Multi-beam or Girder
NE	MD 157(PENIN EXP) over BEAR CREEK	0336500	1960	Baltimore	Steel	Movable - Bascule
R - NE	Solomons Island Rd over The Narrows	0400500	1958	Calvert	Concrete	Slab
E	MD 231 over Patuxent River	0400800	1952	Calvert	Steel	Movable - Swing
	MD 4 SB over Lyons Creek	0401702	1959	Calvert	Steel	Stringer/Multi-beam or Girder
	MD 313 over Choptank River	0500500	1949	Caroline	Steel	Stringer/Multi-beam or Girder
	MD 404 over Watts Creek	0500800	1949	Caroline	Steel	Stringer/Multi-beam or Girder
	MD 313 over Faulkner Branch	0500900	1955	Caroline	Steel	Stringer/Multi-beam or Girder
	MD 404 over Tuckahoe Creek	0501500	1950	Caroline	Steel	Stringer/Multi-beam or Girder
	MD 313 over Marshyhope Creek	0502200	1962	Caroline	Steel	Stringer/Multi-beam or Girder
	MD 26 over Liberty Reservoir	0600100	1954	Carroll	Steel	Stringer/Multi-beam or Girder
	MD 26 over Liberty Reservoir	0600200	1954	Caroline	Steel	Stringer/Multi-beam or Girder
	MD 91 over North Branch Patapsco River	0602000	1965	Caroline	Steel	Stringer/Multi-beam or Girder
	MD 194 over Piney Creek	0603300	1958	Caroline	Concrete	Tee Beam

Eligibility	Description	Bridge No.	Year Built	County	Material	Type
	MD 140 over Richardson Road	0604400	1963	Caroline	Steel	Stringer/Multi-beam or Girder
	MD 91 over CSX Transportation	0604700	1965	Caroline	Steel	Stringer/Multi-beam or Girder
	MD 27 over Maryland Midland Railroad	0604800	1959	Caroline	Concrete	Rigid Frame
E	MD 32 over Liberty Reservoir	0604900	1952	Caroline	Steel	Truss - Deck
NE	MD 97 over Morgan Run	0605000	1959	Caroline	Steel	Stringer/Multi-beam or Girder
	MD 75 over Little Pipe Creek	0605100	1960	Caroline	Steel Continuous	Stringer/Multi-beam or Girder
	MD 26 over MD 97	0605400	1962	Caroline	Steel	Stringer/Multi-beam or Girder
	MD 140 over Big Pipe Creek	0605600	1964	Caroline	Steel	Stringer/Multi-beam or Girder
	MD 272 over Amtrak	0703600	1954	Cecil	Steel	Stringer/Multi-beam or Girder
	MD 273 over Big Elk Creek	0704400	1964	Cecil	Steel	Stringer/Multi-beam or Girder
	MD 279 over Big Elk Creek	0704800	1960	Cecil	Steel Continuous	Stringer/Multi-beam or Girder
	MD 281 over Big Elk Creek	0706000	1960	Cecil	Steel Continuous	Stringer/Multi-beam or Girder
NE	MD 225 over Mattawoman Creek	0802200	1957	Charles	Prestressed (Pretensioned) Concrete	Stringer/Multi-beam or Girder
	MD 254 over Neale Sound	0803800	1963	Charles	Steel	Stringer/Multi-beam or Girder
	MD 234 over Gilbert Swamp Run	0804700	1959	Charles	Prestressed (Pretensioned) Concrete	Box Beam or Girders - Multiple
	US 15 SB over Little Owens Creek	1000300	1954	Frederick	Concrete	Rigid Frame
	US 15 over Owens Creek	1000400	1954	Frederick	Steel	Stringer/Multi-beam or Girder
	MD 806A over High Run	1000600	1950	Frederick	Concrete	Tee Beam
	US 15 SB over Tuscarora Creek	1001000	1950	Frederick	Steel	Stringer/Multi-beam or Girder
NE	MD 17 over CSX Transportation, Potomac River, C&O Canal	1002400	1953	Frederick	Steel Continuous	Girder and Floorbeam System
R - NE	MD 144FA EB over Monocacy River	1003803	1955	Frederick	Steel Continuous	Truss - Deck
	US 340 EBR over MD 180 WBR	1005100	1964	Frederick	Steel	Stringer/Multi-beam or Girder
NE	MD 194 over Little Pipe Creek	1007200	1953	Frederick	Steel Continuous	Stringer/Multi-beam or Girder
	MD 383 over Catocin Creek	1008700	1953	Frederick	Steel	Girder and Floorbeam System

Eligibility	Description	Bridge No.	Year Built	County	Material	Type
	US 15 NB over MD 26	1009701	1957	Frederick	Steel	Stringer/Multi-beam or Girder
NE	Motter Avenue over US 15	1009800	1958	Frederick	Steel	Stringer/Multi-beam or Girder
	US 15 NB over West Seventh Street	1009901	1958	Frederick	Steel	Stringer/Multi-beam or Girder
	US 15 NB over Rosemont Avenue	1010001	1958	Frederick	Steel	Stringer/Multi-beam or Girder
	US 15 NB over US 40, MD 144	1010101	1958	Frederick	Steel	Stringer/Multi-beam or Girder
	US 15 SB over US 40, MD 144	1010102	1958	Frederick	Steel	Stringer/Multi-beam or Girder
	US 15B over US 15/US 40	1010200	1955	Frederick	Steel	Stringer/Multi-beam or Girder
	MD 355 over IS 70	1010500	1955	Frederick	Steel	Stringer/Multi-beam or Girder
	US 15 over Maryland Midland Railroad	1010800	1957	Frederick	Concrete	Rigid Frame
	US 15 NB over MD 77, Hunting Creek	1010900	1957	Frederick	Steel	Stringer/Multi-beam or Girder
	US 15 SB over Fishing Creek	1011100	1961	Frederick	Concrete Continuous	Slab
	US 340 over Catoctin Creek	1011200	1961	Frederick	Steel Continuous	Stringer/Multi-beam or Girder
	US 340 EB over South Mountain Road	1011303	1964	Frederick	Steel	Stringer/Multi-beam or Girder
	US 340 WB over South Mountain Road	1011304	1964	Frederick	Steel	Stringer/Multi-beam or Girder
	MD 17 over US 340	1011400	1964	Frederick	Steel	Stringer/Multi-beam or Girder
	Catholic Church Road over US 340	1011600	1964	Frederick	Steel	Stringer/Multi-beam or Girder
	St. Marks Road over US 340	1011700	1964	Frederick	Steel	Stringer/Multi-beam or Girder
	MD 180 over US 340	1011800	1964	Frederick	Steel	Stringer/Multi-beam or Girder
	Horine Road over US 340	1011900	1965	Frederick	Steel	Stringer/Multi-beam or Girder
	Lander Road over US 340	1012000	1965	Frederick	Steel	Stringer/Multi-beam or Girder
	US 15 SB over Toms Creek	1012400	1965	Frederick	Concrete Continuous	Slab
	US 15 SB over Flat Run	1012500	1965	Frederick	Steel	Stringer/Multi-beam or Girder
	MD 38 over North Branch Potomac River	1100100	1954	Garrett	Steel	Stringer/Multi-beam or Girder

Eligibility	Description	Bridge No.	Year Built	County	Material	Type
	MD 135 over Little Youghiogheny River	1101400	1959	Garrett	Concrete	Slab
	MD 135 over CSX Transportation	1101700	1957	Garrett	Steel	Stringer/Multi-beam or Girder
	MD 946 over US 40 ALT	1102600	1956	Garrett	Steel Continuous	Stringer/Multi-beam or Girder
	US 219 over CSX Transportation And Little Youghiogheny River	1103500	1959	Garrett	Steel	Stringer/Multi-beam or Girder
	US 1 over MD 24	1201500	1964	Harford	Steel	Stringer/Multi-beam or Girder
	MD 136 over Broad Creek	1203200	1961	Harford	Steel	Stringer/Multi-beam or Girder
	MD 23 over Phillips Mill Rd	1206300	1961	Harford	Steel	Stringer/Multi-beam or Girder
NE	MD 23 over Morse Road	1206400	1961	Harford	Steel	Stringer/Multi-beam or Girder
	US 1 over Winters Run	1206500	1963	Harford	Steel	Stringer/Multi-beam or Girder
	US 1 over North Tollgate Road	1206600	1963	Harford	Steel	Stringer/Multi-beam or Girder
	Vale Road over US 1	1206700	1963	Harford	Steel	Stringer/Multi-beam or Girder
NE	US 1 NB over Little Patuxent River	1300701	1955	Howard	Steel Continuous	Stringer/Multi-beam or Girder
	US 29 NB over Frederick Road	1301001	1948	Howard	Steel Continuous	Stringer/Multi-beam or Girder
	US 29 SB over LITTLE PATUXENT RIVER	1301202	1950	Howard	Steel	Stringer/Multi-beam or Girder
	US 29 NB over MIDDLE PATUXENT RIVER	1301301	1951	Howard	Steel Continuous	Stringer/Multi-beam or Girder
	MD 32 over TERRAPIN BRANCH	1302100	1959	Howard	Concrete	Tee Beam
NE	US 40 SB RAMP over US 40 EBR	1303300	1949	Howard	Steel	Stringer/Multi-beam or Girder
	MD 216 over PATUXENT RIVER	1304400	1960	Howard	Steel Continuous	Stringer/Multi-beam or Girder
	TRIDELPHIA ROAD over MD 32	1304500	1961	Howard	Steel	Stringer/Multi-beam or Girder
E	MD 32 over RIV RD,CSX,PATAPSCO RIV	1304600	1963	Howard	Aluminum	Girder and Floorbeam System
	US 301 NB over SASSAFRAS RIVER	1400401	1955	Kent	Steel	Stringer/Multi-beam or Girder
	US 301 SB over SASSAFRAS RIVER	1400402	1955	Kent	Steel	Stringer/Multi-beam or Girder
	US 301 NB over MD 290	1400501	1955	Kent	Steel	Stringer/Multi-beam or Girder
	US 301 SB over MD 290	1400502	1962	Kent	Steel	Stringer/Multi-beam or Girder

Eligibility	Description	Bridge No.	Year Built	County	Material	Type
	MD 289 over RADCLIFF CREEK	1400900	1948	Kent	Steel	Stringer/Multi-beam or Girder
NE	MD 290 over CHESTER RIVER	1401300	1951	Kent	Steel	Stringer/Multi-beam or Girder
	MD 190 over MUDDY BRANCH	1500700	1954	Montgomery	Steel	Stringer/Multi-beam or Girder
	MD 185 over ROCK CREEK	1503000	1957	Montgomery	Steel	Stringer/Multi-beam or Girder
	US 29 over PATUXENT RIVER	1503400	1954	Montgomery	Steel Continuous	Girder and Floorbeam System
	MD 118 over IS 270	1504100	1954	Montgomery	Steel Continuous	Stringer/Multi-beam or Girder
	MD 28 over IS 270 & C-D ROADS	1504800	1955	Montgomery	Steel	Stringer/Multi-beam or Girder
	MD 586 over ROCK CREEK	1506300	1954	Montgomery	Steel	Stringer/Multi-beam or Girder
	US 29 over MD 650	1506700	1957	Montgomery	Steel	Stringer/Multi-beam or Girder
	US 29 NB over PAINT BRANCH	1507601	1957	Montgomery	Steel Continuous	Stringer/Multi-beam or Girder
	US 29 SB over PAINT BRANCH	1507602	1957	Montgomery	Steel Continuous	Stringer/Multi-beam or Girder
	CSX TRANS. over US 29	1507800	1948	Montgomery	Steel	Girder and Floorbeam System
	MD 390 over CSX TRANSPORTATION	1508900	1959	Montgomery	Steel Continuous	Stringer/Multi-beam or Girder
	PEDESTRIAN WALKWAY over MD 191	1509000	1959	Montgomery	Steel	Girder and Floorbeam System
	MD 117 over GREAT SENECA CREEK	1509300	1951	Montgomery	Steel Continuous	Stringer/Multi-beam or Girder
	MD 190 over WATTS BR	1509800	1949	Montgomery	Steel	Arch - Deck (Filled)
	MD 109 over LITTLE BENNETT CREEK	1509900	1951	Montgomery	Steel	Stringer/Multi-beam or Girder
	MD 190 over IS 495	1511000	1962	Montgomery	Steel Continuous	Stringer/Multi-beam or Girder
	MD 191 over IS 495 & THOMAS BRANCH	1511100	1962	Montgomery	Steel	Stringer/Multi-beam or Girder
	GREENTREE RD over IS 495	1511300	1962	Montgomery	Steel	Stringer/Multi-beam or Girder
	FERNWOOD RD over IS 495	1511400	1962	Montgomery	Steel	Stringer/Multi-beam or Girder
	MD 355 SB over IS 270 NBR	1511700	1960	Montgomery	Steel Continuous	Stringer/Multi-beam or Girder
	MD 355 SB over IS 495 OL	1511800	1960	Montgomery	Steel Continuous	Stringer/Multi-beam or Girder

Eligibility	Description	Bridge No.	Year Built	County	Material	Type
NE	MD 355 NB over IS 495 OL	1511900	1960	Montgomery	Steel	Stringer/Multi-beam or Girder
	MD 355 SB over IS 495 IL	1512000	1960	Montgomery	Steel	Stringer/Multi-beam or Girder
	MD 355 NB over IS 495 IL	1512100	1960	Montgomery	Steel	Stringer/Multi-beam or Girder
	US 29 over IS 495	1513500	1959	Montgomery	Steel	Stringer/Multi-beam or Girder
	MD 193 over IS 495	1513600	1958	Montgomery	Steel	Stringer/Multi-beam or Girder
NE	CSX TRANSPORTATION over MD 124	1514800	1955	Montgomery	Steel	Girder and Floorbeam System
NE	US 1 NB over PATUXENT RIVER	1600100	1949	Prince Georges	Steel Continuous	Stringer/Multi-beam or Girder
	US 1 NB over NORTHWEST BRANCH	1600501	1956	Prince Georges	Prestressed (Pretensioned) Concrete	Stringer/Multi-beam or Girder
	US 1 ALT NB over NORTHEAST BRANCH	1600701	1955	Prince Georges	Steel Continuous	Stringer/Multi-beam or Girder
	US 1 ALT SB over NORTHEAST BRANCH	1600702	1955	Prince Georges	Steel Continuous	Stringer/Multi-beam or Girder
NE	US 1 ALT over ANACOSTIA RIVER	1600800	1955	Prince Georges	Steel Continuous	Stringer/Multi-beam or Girder
NE	MD 5 SB over PISCATAWAY CREEK	1601300	1956	Prince Georges	Steel	Stringer/Multi-beam or Girder
	MD 193 over NORTHWEST BRANCH	1601800	1956	Prince Georges	Steel Continuous	Stringer/Multi-beam or Girder
	MD 193 over PAINT BRANCH	1601900	1955	Prince Georges	Steel	Stringer/Multi-beam or Girder
	MD 201 over MD 450	1602500	1955	Prince Georges	Steel	Stringer/Multi-beam or Girder
	MD 201 over CSX TRANS.	1602600	1953	Prince Georges	Concrete	Rigid Frame
	MD 201 NB over US 50	1602701	1957	Prince Georges	Steel	Stringer/Multi-beam or Girder
	MD 201 SB over US 50	1602702	1957	Prince Georges	Steel	Stringer/Multi-beam or Girder
NE	MD 201 NB over AMTRAK,SER RD,BEAVERDAM	1602801	1956	Prince Georges	Steel	Stringer/Multi-beam or Girder
NE	MD 201 SB over AMTRAK,SER RD,BEAVERDAM	1602802	1956	Prince Georges	Steel	Stringer/Multi-beam or Girder
NE	MD 202 NB over AMTRAK & WMATA	1602901	1959	Prince Georges	Steel	Stringer/Multi-beam or Girder
	MD 208 over CSX TRANSPORTATION RR	1603300	1955	Prince Georges	Steel Continuous	Stringer/Multi-beam or Girder
	MD 212 over SLIGO CREEK	1604300	1961	Prince Georges	Steel	Stringer/Multi-beam or Girder

Eligibility	Description	Bridge No.	Year Built	County	Material	Type
	MD 3 NB over PATUXENT RIVER	1605301	1957	Prince Georges	Steel	Stringer/Multi-beam or Girder
	MD 3 SB over PATUXENT RIVER	1605302	1957	Prince Georges	Steel	Stringer/Multi-beam or Girder
	US 301 NB over WESTERN BRANCH	1605401	1959	Prince Georges	Steel	Stringer/Multi-beam or Girder
	US 301 SB over WESTERN BRANCH	1605402	1949	Prince Georges	Steel Continuous	Stringer/Multi-beam or Girder
NE	US 301 SB over MD 5	1605600	1950	Prince Georges	Steel	Stringer/Multi-beam or Girder
R - NE	US 301 NB over TIMOTHY BRANCH	1605701	1950	Prince Georges	Concrete	Arch - Deck (Filled)
R - NE	US 301 SB over TIMOTHY BRANCH	1605702	1950	Prince Georges	Concrete	Arch - Deck (Filled)
	US 301 over MATTAWOMAN CREEK	1605800	1950	Prince Georges	Steel	Stringer/Multi-beam or Girder
	MD 410 over NORTHWEST BRANCH	1606800	1955	Prince Georges	Steel	Stringer/Multi-beam or Girder
	US 50 EB over MD 193	1608903	1955	Prince Georges	Steel	Stringer/Multi-beam or Girder
	US 50 WB over MD 193	1608904	1955	Prince Georges	Steel	Stringer/Multi-beam or Girder
	US 50 EB over FOLLY BRANCH	1609003	1955	Prince Georges	Steel	Stringer/Multi-beam or Girder
	US 50 WB over FOLLY BRANCH	1609004	1955	Prince Georges	Steel	Stringer/Multi-beam or Girder
	US 50 over MD 704	1609200	1955	Prince Georges	Steel	Stringer/Multi-beam or Girder
	MD 4 EBR over PATUXENT RIVER	1609500	1959	Prince Georges	Steel Continuous	Stringer/Multi-beam or Girder
	MD 726 over MD 4	1609600	1959	Prince Georges	Steel	Stringer/Multi-beam or Girder
	MD 4 EBR over US 301	1609703	1959	Prince Georges	Steel	Stringer/Multi-beam or Girder
	MD 4 WB over US 301	1609704	1959	Prince Georges	Steel	Stringer/Multi-beam or Girder
	MD 4 EB over NORFOLK SOUTHERN RR	1609803	1959	Prince Georges	Concrete	Rigid Frame
	MD 4 WB over NORFOLK SOUTHERN RR	1609804	1959	Prince Georges	Concrete	Rigid Frame
	MD 4 EBR over MD 717	1609903	1959	Prince Georges	Steel	Stringer/Multi-beam or Girder
	MD 4 WBR over MD 717	1609904	1959	Prince Georges	Steel	Stringer/Multi-beam or Girder

Eligibility	Description	Bridge No.	Year Built	County	Material	Type
	MD 4 EB over WESTERN BRANCH	1610003	1959	Prince Georges	Steel Continuous	Stringer/Multi-beam or Girder
	MD 4 WB over WESTERN BRANCH	1610004	1959	Prince Georges	Steel Continuous	Stringer/Multi-beam or Girder
	MD 4 NB over MD 980D EBR	1610200	1959	Prince Georges	Steel	Stringer/Multi-beam or Girder
	US 301 SB over MD 214	1610300	1959	Prince Georges	Steel	Stringer/Multi-beam or Girder
	MD 214 EBR over US 301 NBR	1610403	1959	Prince Georges	Steel	Stringer/Multi-beam or Girder
	MD 214 WBR over US 301 NBR	1610404	1959	Prince Georges	Steel	Stringer/Multi-beam or Girder
	MD 202 over US 50	1610500	1959	Prince Georges	Steel	Stringer/Multi-beam or Girder
	MD 202 RAMP 'E' over US 50	1610600	1959	Prince Georges	Steel	Stringer/Multi-beam or Girder
	CSX TRANSPORTATION over US 50 & MD RTE 459	1610700	1959	Prince Georges	Steel	Girder and Floorbeam System
	MD 4 SB over RACE TRACK RD	1610803	1960	Prince Georges	Prestressed (Pretensioned) Concrete	Box Beam or Girders - Multiple
	MD 4 NB over RACE TRACK RD	1610804	1960	Prince Georges	Prestressed (Pretensioned) Concrete	Box Beam or Girders - Multiple
	MD 381 over NORFOLK SOUTHERN RR	1611200	1962	Prince Georges	Concrete	Slab
	US 50 over US 50PA	1611300	1961	Prince Georges	Steel	Stringer/Multi-beam or Girder
	US 50 over AMTRAK & WMATA	1611400	1959	Prince Georges	Steel	Stringer/Multi-beam or Girder
	MD 459 over US 50	1611700	1962	Prince Georges	Steel	Stringer/Multi-beam or Girder
	US 50 over MD 295	1611800	1957	Prince Georges	Steel	Stringer/Multi-beam or Girder
	MD 212 over IS 495 OL	1612000	1964	Prince Georges	Steel	Stringer/Multi-beam or Girder
	CHERRY HILL RD over IS 95 OL	1613200	1963	Prince Georges	Steel	Stringer/Multi-beam or Girder
	US 1 over IS 95	1613400	1963	Prince Georges	Steel Continuous	Stringer/Multi-beam or Girder
	MD 201 NB over IS 95	1614001	1963	Prince Georges	Steel Continuous	Stringer/Multi-beam or Girder
	MD 201 SB over IS 95	1614002	1963	Prince Georges	Steel Continuous	Stringer/Multi-beam or Girder
	MD 295 NB over IS 95	1614201	1963	Prince Georges	Steel Continuous	Stringer/Multi-beam or Girder

Eligibility	Description	Bridge No.	Year Built	County	Material	Type
	MD 295 SB over IS 95	1614202	1963	Prince Georges	Steel Continuous	Stringer/Multi-beam or Girder
	US 50 over IS 95	1614600	1958	Prince Georges	Steel	Stringer/Multi-beam or Girder
	MD 704 over IS 95	1614700	1964	Prince Georges	Steel Continuous	Stringer/Multi-beam or Girder
	MD 202 over IS 95	1615000	1963	Prince Georges	Steel Continuous	Stringer/Multi-beam or Girder
	MD 210 NB over IS 95	1616901	1961	Prince Georges	Steel Continuous	Stringer/Multi-beam or Girder
	MD 210 SB over IS 95	1616902	1961	Prince Georges	Steel Continuous	Stringer/Multi-beam or Girder
	MD 212 over IS 495 IL	1617400	1964	Prince Georges	Steel	Stringer/Multi-beam or Girder
	MD 4 NB over MD 223	1618101	1962	Prince Georges	Steel	Stringer/Multi-beam or Girder
	MD 4 SB over MD 223	1618102	1962	Prince Georges	Steel	Stringer/Multi-beam or Girder
	US 50/301 over COX CREEK	1700400	1950	Queen Annes	Steel	Stringer/Multi-beam or Girder
	US 50/301 EB over PINEY CREEK	1700503	1950	Queen Annes	Steel	Stringer/Multi-beam or Girder
	US 50/301 WB over PINEY CREEK	1700504	1950	Queen Annes	Steel	Stringer/Multi-beam or Girder
Rec. E	MD 18B over KENT ISLAND NARROW	1700600	1951	Queen Annes	Steel	Movable - Bascule
	US 50 WB over US 301	1701000	1950	Queen Annes	Steel	Stringer/Multi-beam or Girder
	US 301 NB over MD 290	1701101	1955	Queen Annes	Steel	Stringer/Multi-beam or Girder
	US 301 NB over RED LION BRANCH	1701201	1955	Queen Annes	Steel	Stringer/Multi-beam or Girder
	US 301 NB over UNICORN BRANCH	1701301	1955	Queen Annes	Steel	Stringer/Multi-beam or Girder
	US 301 NB over CHESTER RIVER	1701401	1955	Queen Annes	Steel	Stringer/Multi-beam or Girder
	MD 313 over CHESTER RIVER	1703000	1961	Queen Annes	Steel	Stringer/Multi-beam or Girder
	MD 404 over NORWICH CREEK	1703200	1949	Queen Annes	Steel	Stringer/Multi-beam or Girder
NE	MD 5 over ST MARYS RIVER	1800600	1955	St Marys	Concrete	Tee Beam
	MD 234 over CHAPTICO CREEK	1801500	1959	St Marys	Prestressed (Pretensioned) Concrete	Box Beam or Girders - Multiple
NE	MD 234 over ST CLEMENTS CREEK	1801600	1950	St Marys	Steel	Stringer/Multi-beam or Girder

Eligibility	Description	Bridge No.	Year Built	County	Material	Type
	MD 249 over ST GEORGES CREEK	1802600	1957	St Marys	Steel Continuous	Stringer/Multi-beam or Girder
	US 13 NB over KINGS CREEK	1900301	1962	Somerset	Concrete	Tee Beam
	US 13 SB over KINGS CREEK	1900302	1962	Somerset	Prestressed (Pretensioned) Concrete	Box Beam or Girders - Multiple
NE	US 13 NB over NORFOLK SOUTHERN RR	1900401	1957	Somerset	Steel	Stringer/Multi-beam or Girder
	US 13 SB over NORFOLK SOUTHERN RR	1900402	1965	Somerset	Steel	Stringer/Multi-beam or Girder
	MD 413 over BIG ANNEMESSEX RIVER	1901100	1949	Somerset	Steel	Stringer/Multi-beam or Girder
	US 13 NB over MANOKIN RIVER	1901201	1958	Somerset	Steel	Stringer/Multi-beam or Girder
	US 13 SB over MANOKIN RIVER	1901202	1964	Somerset	Prestressed (Pretensioned) Concrete	Box Beam or Girders - Multiple
	MD 33 over OAK CREEK	2000200	1965	Talbot	Prestressed (Pretensioned) Concrete	Box Beam or Girders - Multiple
	US 50 EB over NORTH BRANCH SKIPTON CRE	2000403	1960	Talbot	Steel	Stringer/Multi-beam or Girder
	US 50 WB over NORTH BRANCH SKIPTON CRE	2000404	1948	Talbot	Steel	Stringer/Multi-beam or Girder
	US 50 EB over SOUTH BRANCH SKIPTON CRE	2000503	1960	Talbot	Steel	Stringer/Multi-beam or Girder
	US 50 WB over SOUTH BRANCH SKIPTON CRE	2000504	1948	Talbot	Steel	Stringer/Multi-beam or Girder
	MD 309 over NORWICH CREEK	2002400	1960	Talbot	Prestressed (Pretensioned) Concrete	Box Beam or Girders - Multiple
	MD 34 over ANTIETAM CREEK	2100300	1958	Washington	Steel Continuous	Stringer/Multi-beam or Girder
	MD 34 over BEAVER CREEK	2100500	1957	Washington	Concrete	Tee Beam
NE	US 40 ALT over LANDIS SPRING BRANCH	2101900	1949	Washington	Masonry (Stone)	Arch - Deck (Filled)
	US 40 ALT over LITTLE BEAVER CREEK	2102100	1949	Washington	Masonry (Stone)	Arch - Deck (Filled)
	US 340 over ISRAEL CRK, ABANDONED RR	2103400	1963	Washington	Steel Continuous	Stringer/Multi-beam or Girder
	MD 34 over LITTLE ANTIETAM CREEK	2105000	1958	Washington	Steel Continuous	Stringer/Multi-beam or Girder
	MD 58 over IS 81	2105100	1958	Washington	Steel	Stringer/Multi-beam or Girder
	US 40 EB over IS 81	2105203	1958	Washington	Steel	Stringer/Multi-beam or Girder
	US 40 WB over IS 81	2105204	1958	Washington	Steel	Stringer/Multi-beam or Girder
	MD 63 over CSX TRANS.	2105700	1959	Washington	Steel	Stringer/Multi-beam or Girder

Eligibility	Description	Bridge No.	Year Built	County	Material	Type
	MD 144WA over IS 81	2106900	1963	Washington	Steel Continuous	Stringer/Multi-beam or Girder
	US 11 over IS 81	2108300	1965	Washington	Steel Continuous	Stringer/Multi-beam or Girder
	MD 68 over WINCHESTER & WESTERN RR	2108500	1965	Washington	Steel	Stringer/Multi-beam or Girder
	US 522 over IS 70 EBR, RAMP 'A'	2109000	1965	Washington	Steel	Stringer/Multi-beam or Girder
	US 40 EB over IS 70 WBR	2109300	1965	Washington	Steel	Stringer/Multi-beam or Girder
	MD 56 over IS 70	2109600	1964	Washington	Steel	Stringer/Multi-beam or Girder
	MD 68 over IS 70	2109900	1965	Washington	Steel Continuous	Stringer/Multi-beam or Girder
	US 50 EB over POCOMOKE RIVER	2200103	1964	Wicomico	Steel	Stringer/Multi-beam or Girder
	US 50 WB over POCOMOKE RIVER	2200104	1964	Wicomico	Steel	Stringer/Multi-beam or Girder
	US 13 SB over LEONARD POND RUN	2200202	1952	Wicomico	Concrete	Tee Beam
	US 13 BUS SB over NORFOLK SOUTHERN RR	2200302	1951	Wicomico	Steel	Girder and Floorbeam System
NE	US 13 BUS SB over TONYTANK POND	2200502	1954	Wicomico	Concrete	Slab
	US 50 EB over BARREN CREEK	2200803	1965	Wicomico	Steel	Stringer/Multi-beam or Girder
	US 50 WB over BARREN CREEK	2200804	1950	Wicomico	Steel	Stringer/Multi-beam or Girder
	MD 353 over AYDELOTTE BRANCH	2202500	1961	Wicomico	Steel	Stringer/Multi-beam or Girder
NE	US 13 BUS over US 50 BUS	2202600	1961	Wicomico	Steel	Stringer/Multi-beam or Girder
	NORFOLK & SOUTHERN over US 50 BUS	2202700	1961	Wicomico	Steel	Stringer/Multi-beam or Girder
	US 50 BUS over WICOMICO RIVER	2202800	1962	Wicomico	Steel	Movable - Bascule
	US 13 NB over WAGRAM CREEK	2300501	1954	Worcester	Concrete	Slab
E	US 113 BU over PURNELL BRANCH	2300800	1952	Worcester	Concrete	Slab
	US 13 NB over POCOMOKE RIVER	2301601	1959	Worcester	Steel	Stringer/Multi-beam or Girder
	MD 611 over SINEPUXENT BAY	2301800	1964	Worcester	Prestressed (Pretensioned) Concrete	Box Beam or Girders - Multiple

Appendix E: Resume

Anne E. Bruder is Senior Architectural Historian for the Maryland Department of Transportation, State Highway Administration where she has worked since 2001. Previously she worked for the Maryland Historical Trust. Ms. Bruder had more than 12 years of experience in the fields of architectural history and historic preservation. She has conducted numerous historic building surveys in Maryland and written many determinations of eligibility for SHA's Section 106 compliance projects. She has also written Memoranda of Agreement to address adverse impacts to historic properties caused by SHA's projects. She has presented lectures about Maryland's post-World War II suburban development to the Society of Architectural Historians and the Transportation Research Board's Committee on Historic and Archaeological Preservation in Transportation. Ms. Bruder is the project manager for SHA's Historic Highway Bridge Program. She received her A.B. from Smith College in 1992 and her M.Arch.H. from the University of Virginia in 1996.

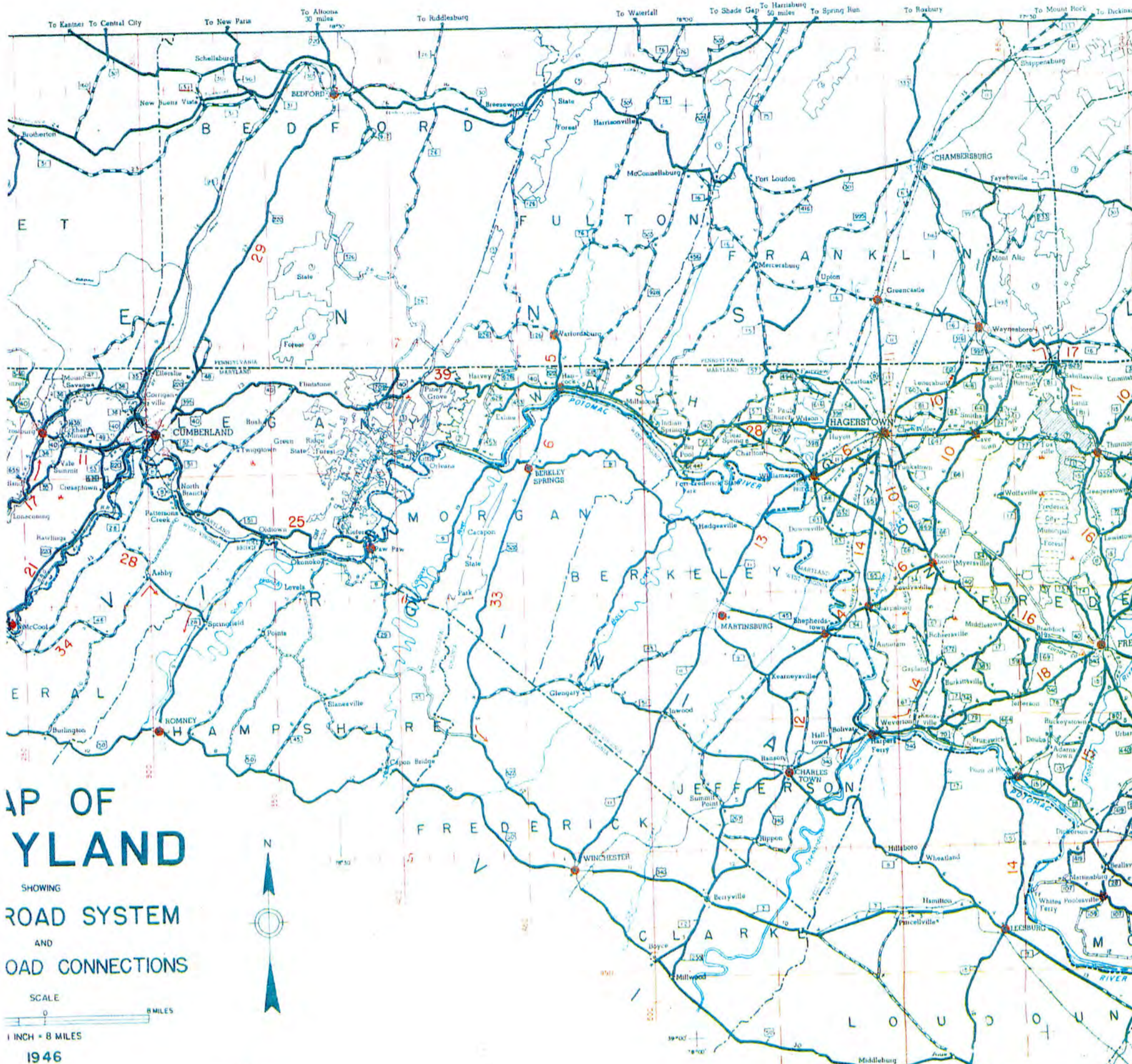

MAP OF MARYLAND

SHOWING
ROAD SYSTEM
AND
ROAD CONNECTIONS

SCALE
1 INCH = 8 MILES
1946

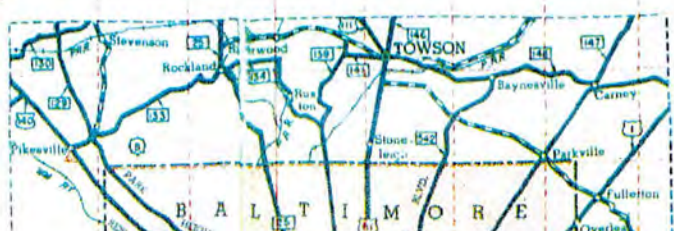
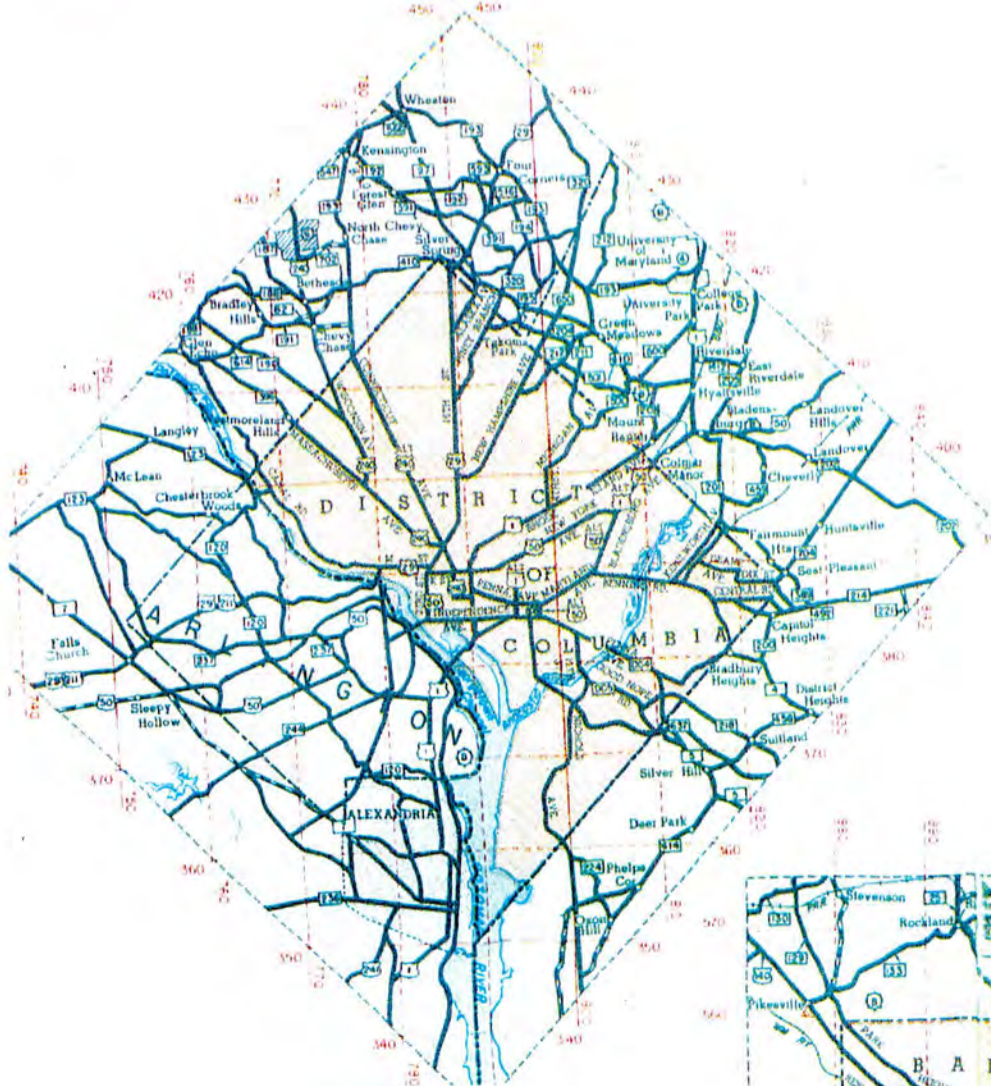

LEGEND

- STATE BOUNDARY
- COUNTY BOUNDARY
- CORPORATE BOUNDARY
- RESERVATION BOUNDARY
- NATIONAL AND STATE
- RAILROAD - ANY NUMBER OF TRACKS
- RAILROAD - USED BY SINGLE OPERATING COMPANY
- RAILROAD - ELECTRIC INTERURBAN OR SUBURBAN
- NAVIGABLE STREAM
- FERRY - TOLL
- CANAL
- COUNTY SEAT
- OTHER CITIES AND VILLAGES
- STATE OR NATIONAL CAPITAL
- INCORPORATED CITY OR VILLAGE

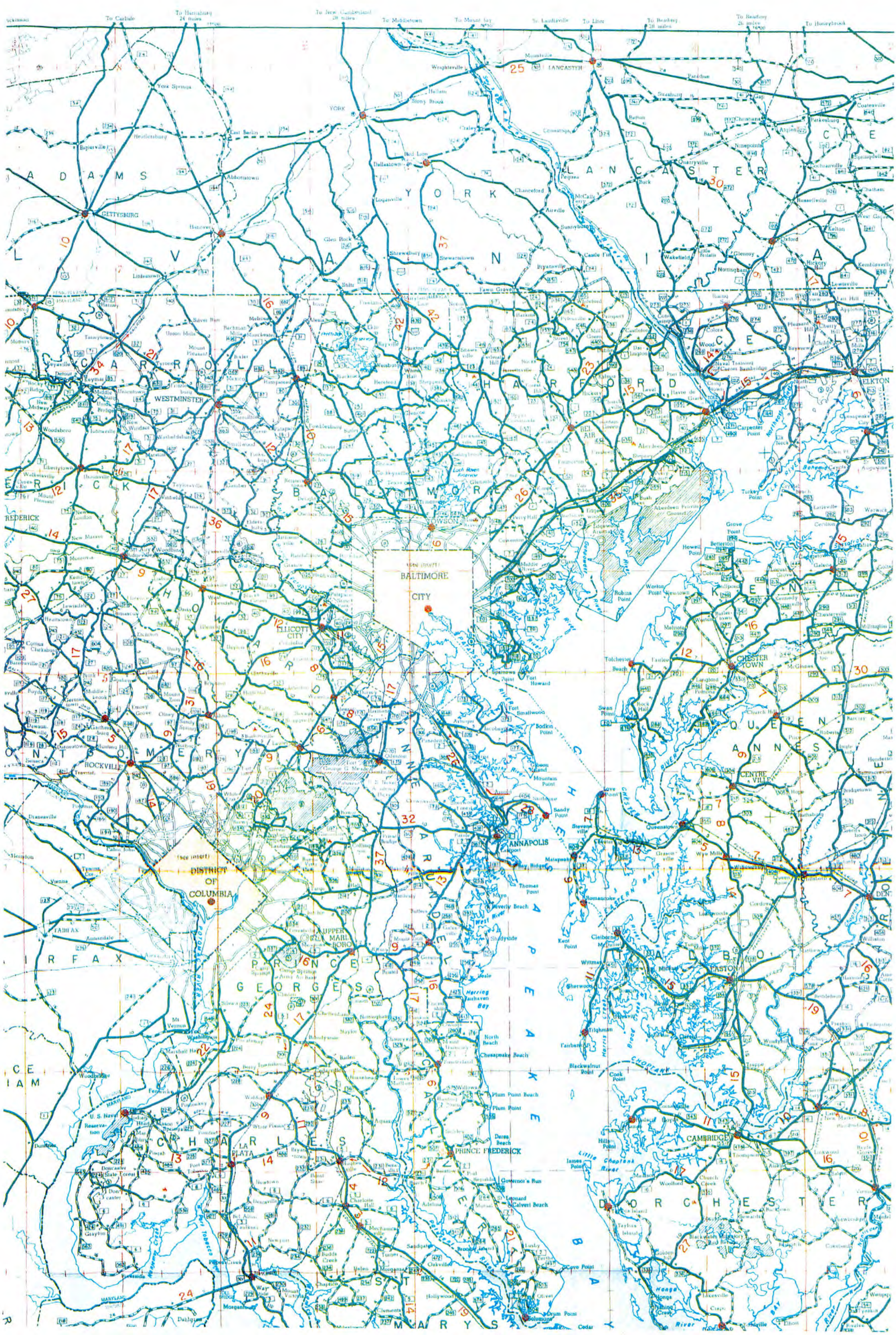

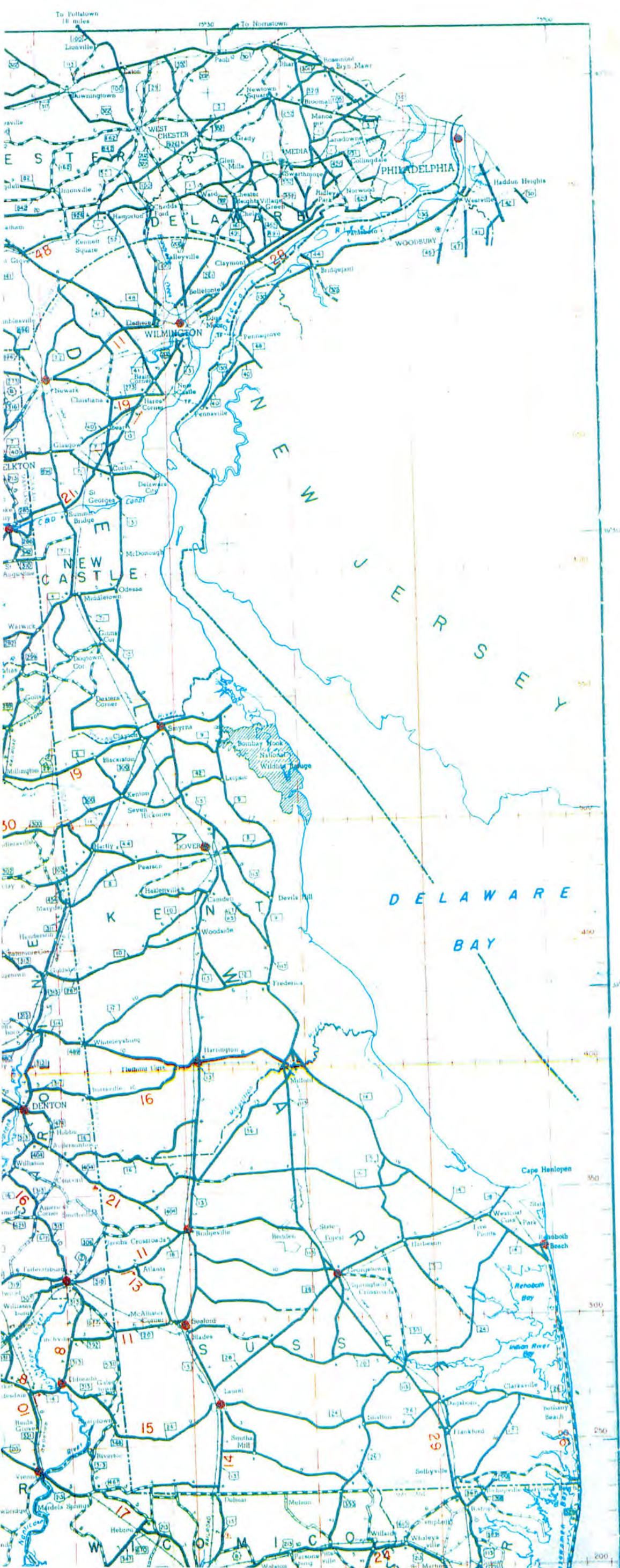

**HELP KEEP OUR HIGHWAYS SAFE
OBEY TRAFFIC SIGNS AND SIGNALS**



REQUIRES FULL STOP AND YIELDING OF RIGHT OF WAY TO ALL APPROACHING VEHICLES ON THRU HIGHWAY



ADVANCE WARNING OF RAILROAD GRADE CROSSING IN CONJUNCTION WITH PAYMENT MARKING



INDICATES MAXIMUM SPEED LIMIT

TYPES OF SYMBOL SIGNS



ADVANCE WARNING OF RIGHT INTERSECTION



ADVANCE WARNING OF "DEAD END" ROAD



ADVANCE WARNING OF "Y" INTERSECTION



ADVANCE WARNING OF CROSS ROAD



USED WHEN CURVE CAN BE NEGOTIATED AT MAXIMUM POSTED SPEED



USED WHEN CURVE SHOULD BE NEGOTIATED WITH CAUTION AT REDUCED SPEED



USED ON EXTREMELY SHARP CURVES WHERE SPEED MUST BE MATERIALLY REDUCED



USED ON DANGEROUS REVERSE CURVES WHERE CAUTION SHOULD BE EXERCISED AT ALL TIMES



USED IN CONJUNCTION WITH CURVE SYMBOL SIGN TO INDICATE SAFE DRIVING SPEED



JUNCTION ROUTE MARKER



ROUTE TURN MARKER



FOR PEDESTRIAN SAFETY



INDICATES BEGINNING OF SCHOOL ZONE AREA

ROAD SURFACE MARKINGS



ALL SURFACE MARKINGS ARE YELLOW EXCEPT "NO PASSING ZONES" WHICH ARE INDICATED BY WHITE LINES

THE WHITE LINE IS USED AROUND CURVES AND OVER HILLTOPS, WHERE THE SIGHT DISTANCE IS LIMITED, OR ON APPROACHES TO RAILROAD CROSSINGS AND THROUGH SCHOOL ZONES OR AS A DOUBLE BARRIER LINE ON THREE OR FOUR LANE HIGHWAYS

WHEREVER THERE IS A DOUBLE WHITE BARRIER LINE OR A SINGLE WHITE LINE TO THE RIGHT OF A YELLOW CENTER LINE IT IS UNLAWFUL AND UNLAWFUL TO CROSS SUCH A LINE

THE SIGNS, SIGNALS, AND TRAFFIC MARKINGS HAVE BEEN PLACED FOR YOUR GUIDANCE AND CONVENIENCE—OBEY THEM FOR YOUR PROTECTION AND SAFETY

RULES OF THE ROAD

SPEED LIMITS Unless otherwise posted, Maryland's speed limits are:

DUAL DIVIDED HIGHWAYS

Maximum in open rural areas	55 M. P. H.
Outlying sections	35 M. P. H.
Business sections	30 M. P. H.

UNDIVIDED HIGHWAYS

Maximum in open rural areas	50 M. P. H.
Outlying sections	30 M. P. H.
Business sections	25 M. P. H.

HAND SIGNALS The law requires you to signal with your hand before turning or stopping. To make a right turn, pull over to the right and signal "come on ahead" by moving your hand in a circular motion. For a left turn, pull to the center, point your hand straight to left, hold it still several seconds. Before stopping, drop your hand toward the ground with palm to rear, hold hand still several seconds.



RIGHT TURN



LEFT TURN



STOP OR SLOW

STOP SIGNS Before entering or crossing a "through highway", stop and yield right of way to all approaching vehicles. Bring your car to a full stop 5 feet in the rear of streetcars discharging or receiving passengers and 10 feet from the rear or front of a school bus receiving or discharging school children.

TRAFFIC CONTROL SIGNALS Traffic signals used in Maryland are:

- (1) Green or go. Proceed straight ahead or make right or left turns where permitted.
- (2) Amber or caution. Warning of changing light. Prepare to stop.

CITIES, TOWNS AND VILLAGES

Table listing cities, towns, and villages with their corresponding grid coordinates (e.g., A, B, C, D, E, F, G, H, I, J, K, L, M, N, O, P, Q, R, S, T, U, V, W, X, Y, Z).

OTHER GEOGRAPHIC PLACES

Table listing other geographic places with their corresponding grid coordinates (e.g., A, B, C, D, E, F, G, H, I, J, K, L, M, N, O, P, Q, R, S, T, U, V, W, X, Y, Z).

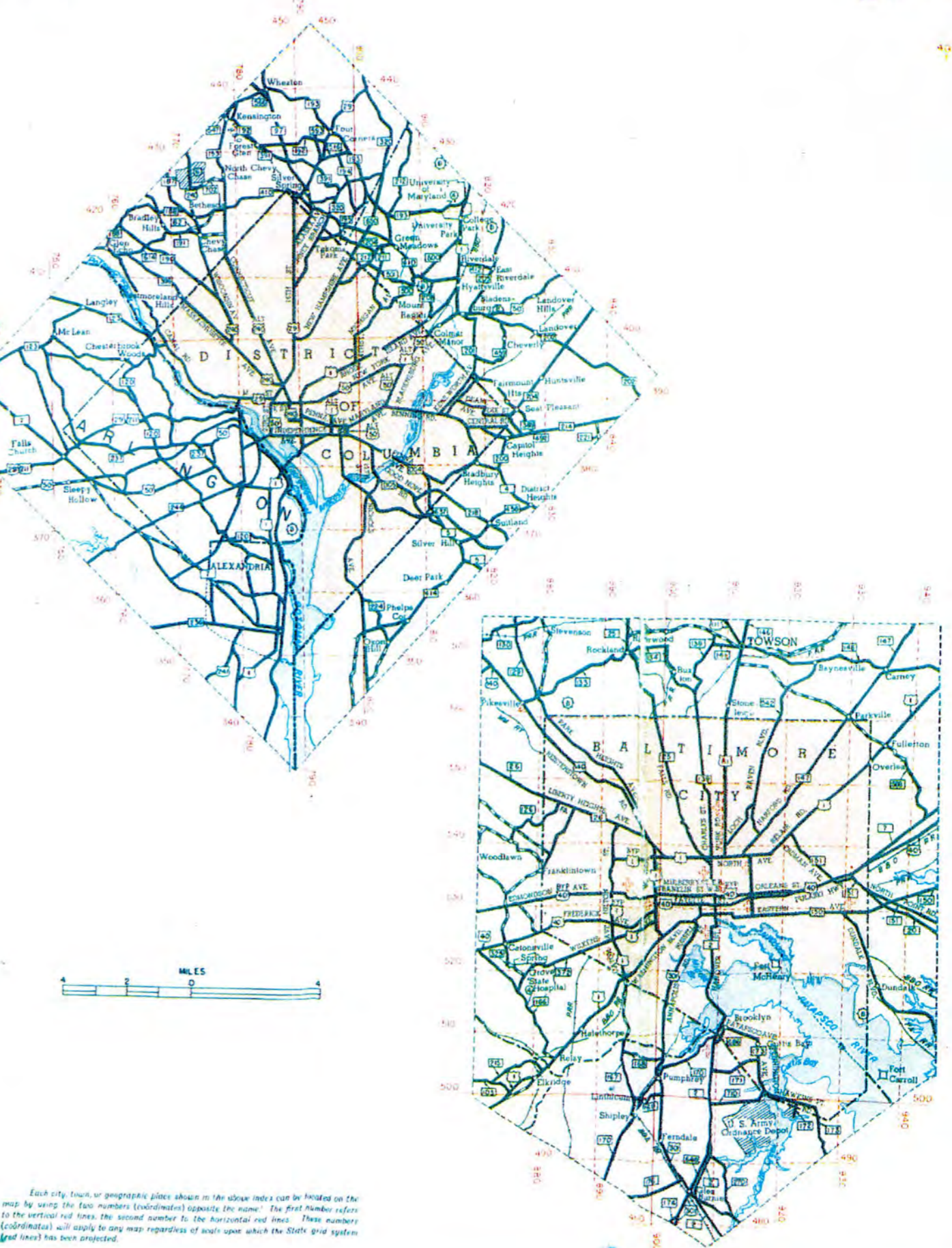

Each city, town, or geographic place shown in the above index can be located on the map by using the two numbers (indicated) opposite the name. The first number refers to the vertical red line, the second number to the horizontal red lines. These numbers (coordinates) will apply to any map regardless of scale upon which the State grid system (red lines) has been projected.

ATTACHED AT: 1946/1947
MARIANO STATE ROAD MAP

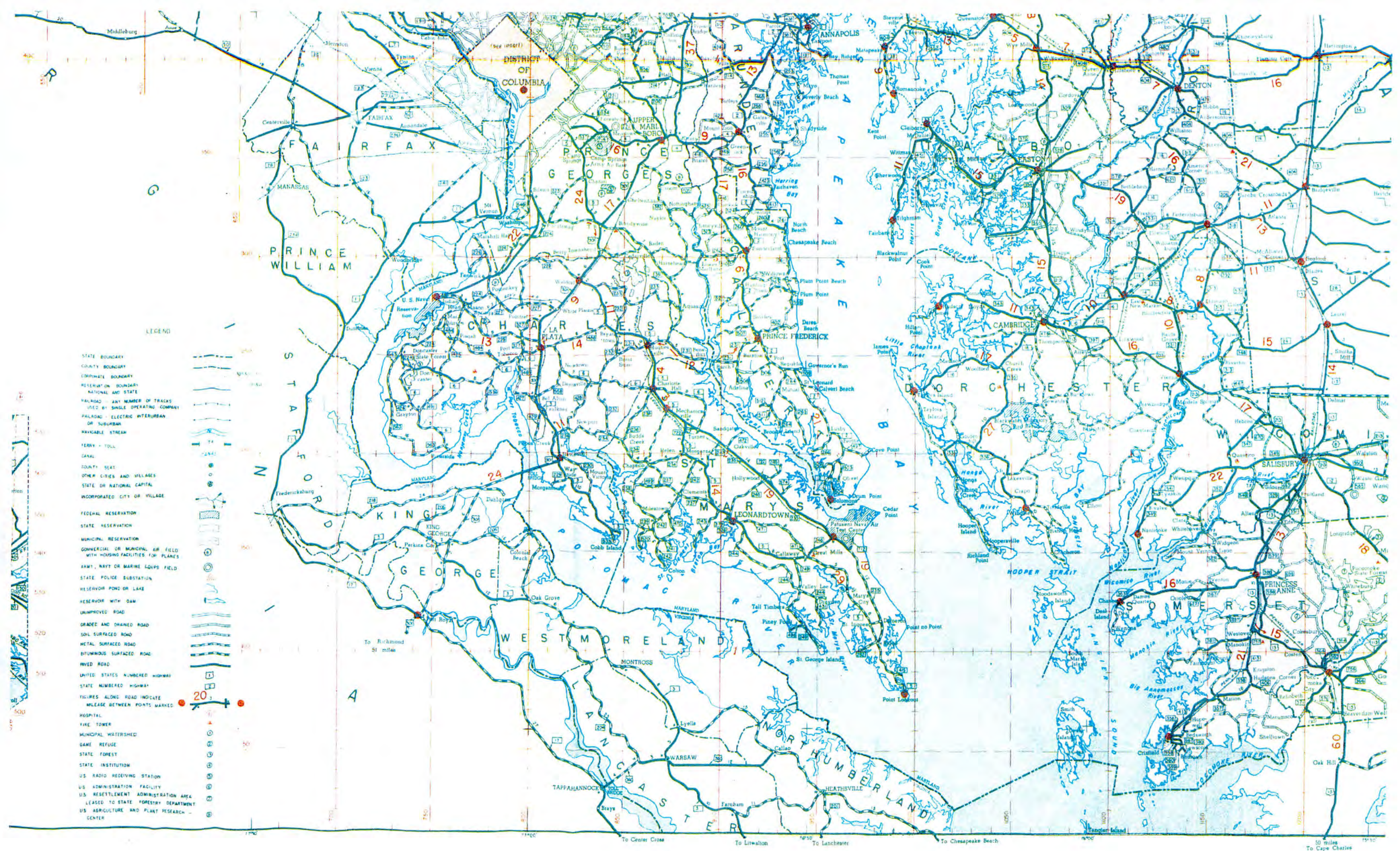

LEGEND

- STATE BOUNDARY
- COUNTY BOUNDARY
- CORPORATE BOUNDARY
- RESERVATION BOUNDARY
- NATIONAL AND STATE
- RAILROAD - ANY NUMBER OF TRACKS USED BY SINGLE OPERATING COMPANY
- RAILROAD - ELECTRIC INTERURBAN OR SUBURBAN
- NAVIGABLE STREAM
- FERRY - TOLL
- CANAL
- COUNTY SEAT
- OTHER CITIES AND VILLAGES
- STATE OR NATIONAL CAPITAL
- INCORPORATED CITY OR VILLAGE
- FEDERAL RESERVATION
- STATE RESERVATION
- MUNICIPAL RESERVATION
- COMMERCIAL OR MUNICIPAL AIR FIELD WITH HOUSING FACILITIES FOR PLANES
- ARMY, NAVY OR MARINE CORPS FIELD
- STATE POLICE SUBSTATION
- RESERVOIR POND OR LAKE
- RESERVOIR WITH DAM
- UNIMPROVED ROAD
- GRADED AND DRAINED ROAD
- SOIL SURFACED ROAD
- METAL SURFACED ROAD
- BITUMINOUS SURFACED ROAD
- HYDRO ROAD
- UNITED STATES NUMBERED HIGHWAY
- STATE NUMBERED HIGHWAY
- FIGURES ALONG ROAD INDICATE MILEAGE BETWEEN POINTS MARKED
- HOSPITAL
- FIRE TOWER
- MUNICIPAL WATERSHED
- GAME REFUGE
- STATE FOREST
- STATE INSTITUTION
- U.S. RADIO RECEIVING STATION
- U.S. ADMINISTRATION FACILITY
- U.S. RESETTLEMENT ADMINISTRATION AREA
- LEASED TO STATE FORESTRY DEPARTMENT
- U.S. AGRICULTURE AND PLANT RESEARCH CENTER

50 miles
To Cape Charles

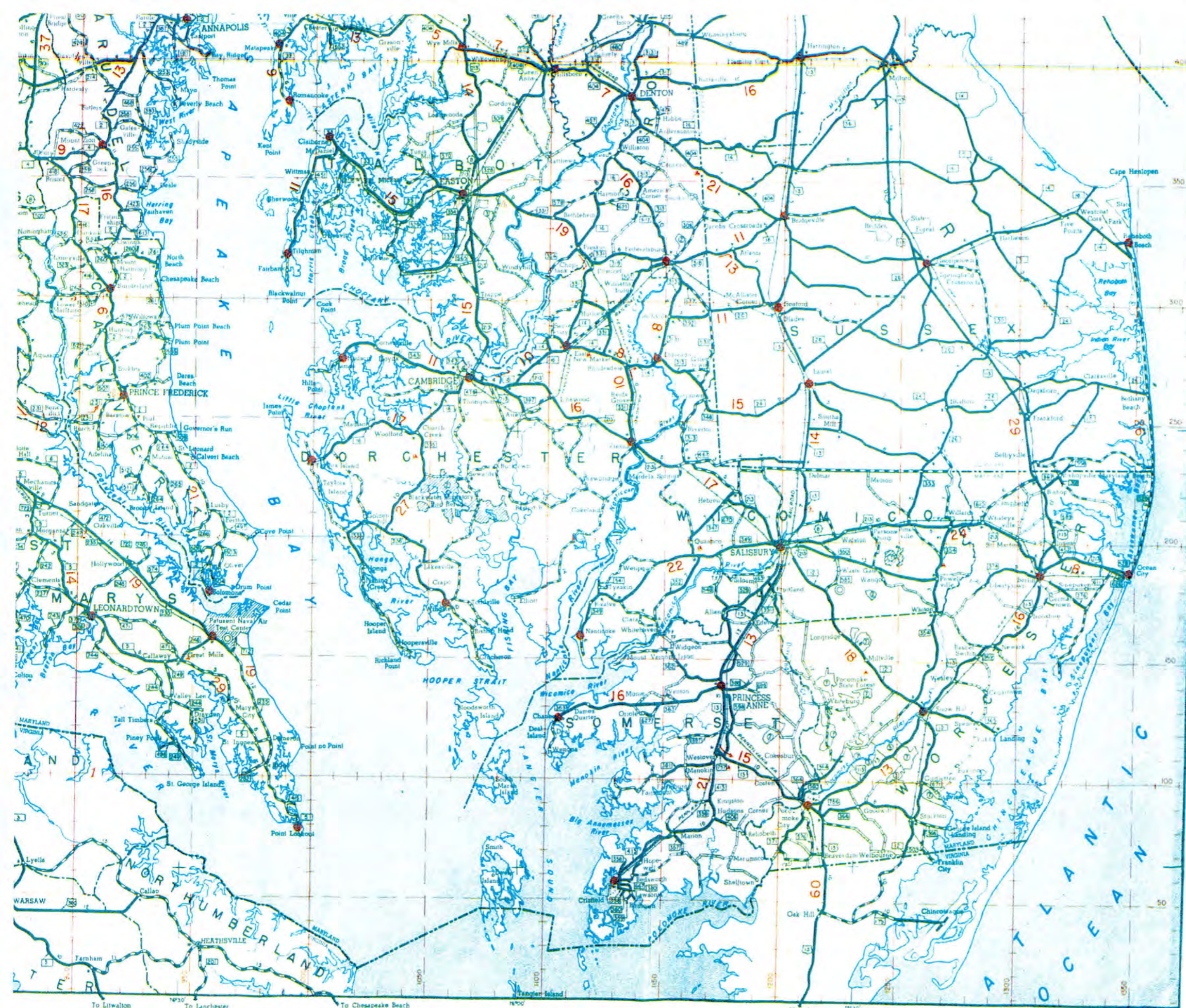

RULES OF THE ROAD

SPEED LIMITS Unless otherwise posted, Maryland's speed limits are:

DUAL DIVIDED HIGHWAYS	
Maximum in open rural areas	55 M. P. H.
Outlying sections	35 M. P. H.
Business sections	30 M. P. H.
UNDIVIDED HIGHWAYS	
Maximum in open rural areas	50 M. P. H.
Outlying sections	30 M. P. H.
Business sections	25 M. P. H.

HAND SIGNALS The law requires you to signal with your hand before turning or stopping. To make a right turn, pull over to the right and signal "come on ahead" by moving your hand in a circular motion. For a left turn, pull to the center, point your hand straight to left, hold it still several seconds. Before stopping, drop your hand toward the ground with palm to rear; hold hand still several seconds.



STOP SIGNS Before entering or crossing a "through highway", stop and yield right of way to all approaching vehicles. Bring your car to a full stop 5 feet in the rear of streetcars discharging or receiving passengers and 10 feet from the rear or front of a school bus receiving or discharging school children.

- TRAFFIC CONTROL SIGNALS** Traffic signals used in Maryland are:
- (1) Green or go: Proceed straight ahead or make right or left turns where permitted.
 - (2) Amber or caution: Warning of changing light. Prepare to stop.
 - (3) Red or stop: Remain standing until light turns green.
 - (4) Green arrows:
 - a. Vertical arrow: Proceed straight; do not make right or left turn.
 - b. Right arrow: Make only right turn.
 - c. Left arrow: Make only left turn.
 Green arrows take precedent over the indication of the regular signal which often is red when the arrows are lighted.
 - (5) Flashing red: Used on side road face of flashing signal and should be obeyed same as Stop sign.
 - (6) Flashing amber: Reduce speed through intersection.
- Obey these unless otherwise directed by an officer.**

PARKING Do not park near the top of a hill, or on a curve where the view is obstructed in either direction, or at an intersection or on a paved highway wherever there are white surface markings. Observe all No Parking signs. Except in an emergency, for your own protection, vehicles should never be parked in any area where it is impossible to stop the vehicle well off the roadway.

VEHICLES SOUNDING SIRENS Fire or police department vehicles and ambulances sounding sirens or gongs always have the right of way over all other traffic. When such vehicles approach pull to the right curb and wait till they have passed.

ACCIDENTS If you are involved in an accident, you must stop and give your name, address, and license number. You must also send a written report of the accident within 24 hours to the Department of Motor Vehicles, Baltimore, if a person is injured or if property damage is \$50 or more.

HEADLIGHTS Maryland law requires you to lower your headlight beam when you are within 500 feet of an approaching vehicle.

DRIVER'S LICENSE When operating a motor vehicle you must always have in your possession driver's license and vehicle registration certificate.

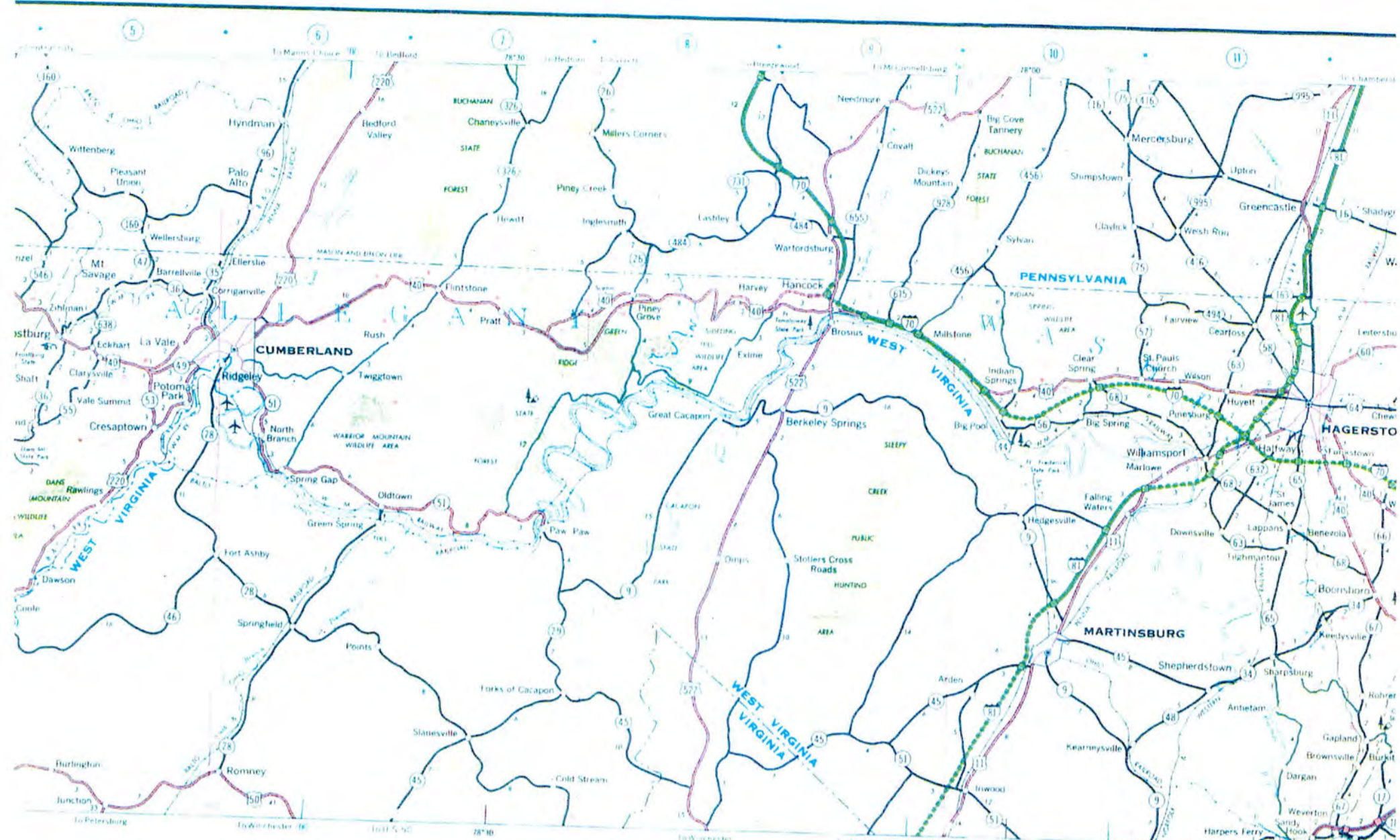

STATE OF MARYLAND STATE HIGHWAY SYSTEM AND CONNECTIONS

HIGHWAY SYSTEM

- | | |
|--|--------------------------------------|
| | Interstate Highways |
| | U.S. Highways |
| | State Highways |
| | Interchange |
| | Point of Interest or Scenic Overlook |
| | Colleges and Universities |
| | National and State Capitals |
| | State Police Barracks |
| | Airports |
| | Expressways |
| | Divided Highways |
| | Through Highways |
| | State Secondary Highways |
| | County Highways |
| | Railroads |
| | Canals |
| | Ferries |

IN MILES
0 10 20
CENTRAL TRANSVERSE
MERIDIAN SHOWN IN BLUE

1965

Prepared by the
MARYLAND STATE ROADS COMMISSION
PLANNING AND PROGRAMMING DIVISION

LAMBERT CONFORMAL CONIC PROJECTION

CITIES AND TOWNS

- | | |
|--|--------------------------------------|
| | 0-1000 |
| | 1000-5000 |
| | 5000-10000 |
| | 10000 and over |
| | County Seats |
| | Corporate Limits of Principal Cities |
| | Reservations |
| | Forest Areas |
| | Roadside Picnic Areas |
| | State Parks |
| | State Parks with Camping Facilities |

NOTE: HIGHWAYS AND STREETS WITHIN THE DISTRICT OF COLUMBIA AND BALTIMORE CITY ARE NOT MAINTAINED BY THE MARYLAND STATE ROADS COMMISSION. PRIMARY AND SECONDARY HIGHWAY SYSTEMS APPLY TO MARYLAND ONLY.

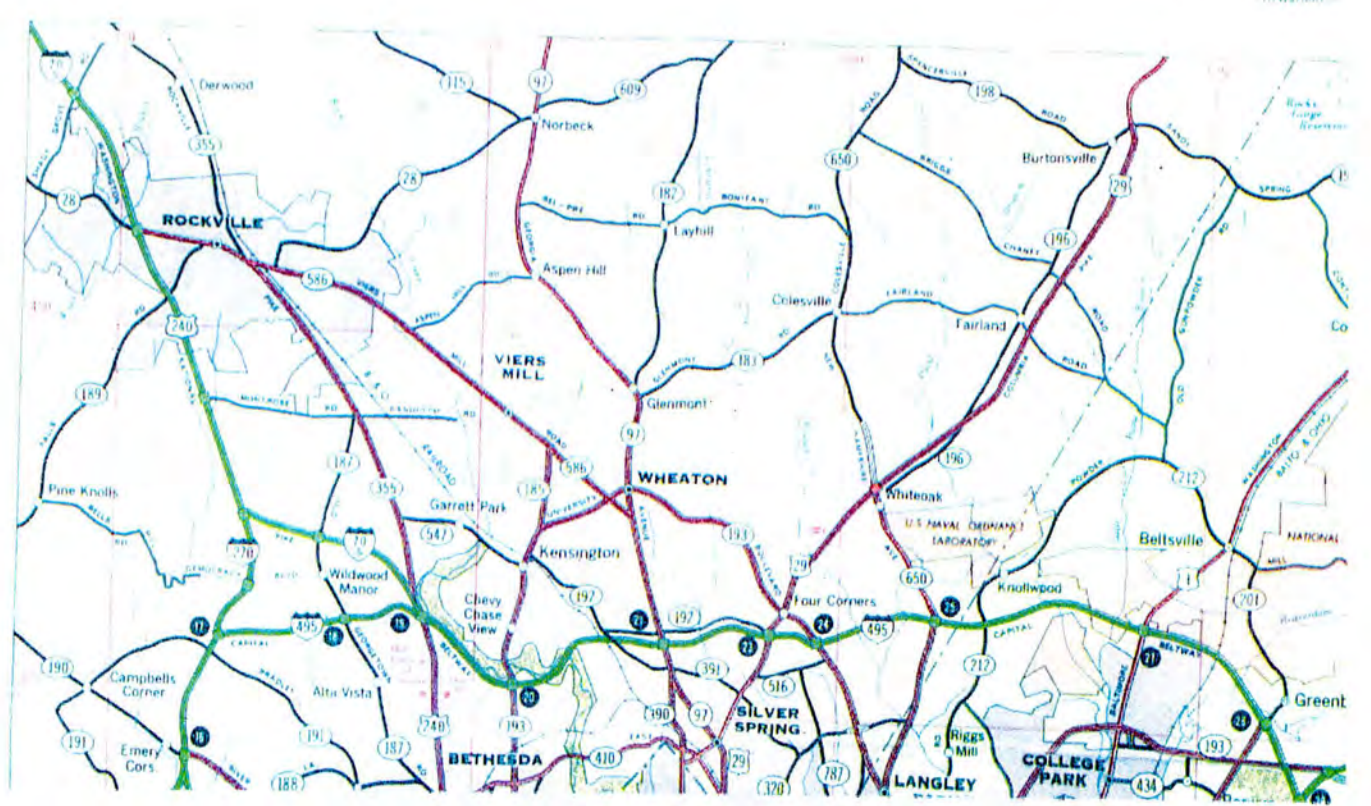
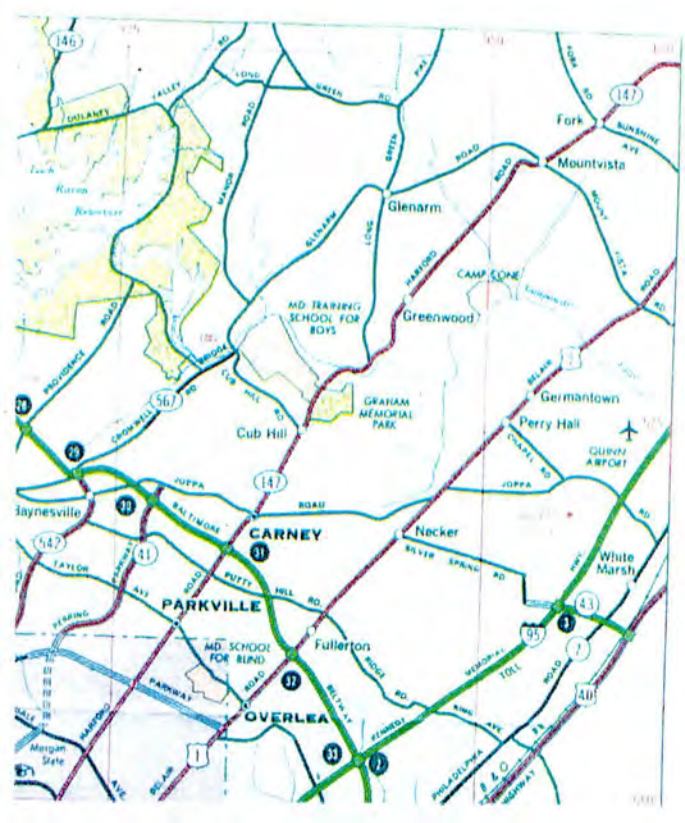

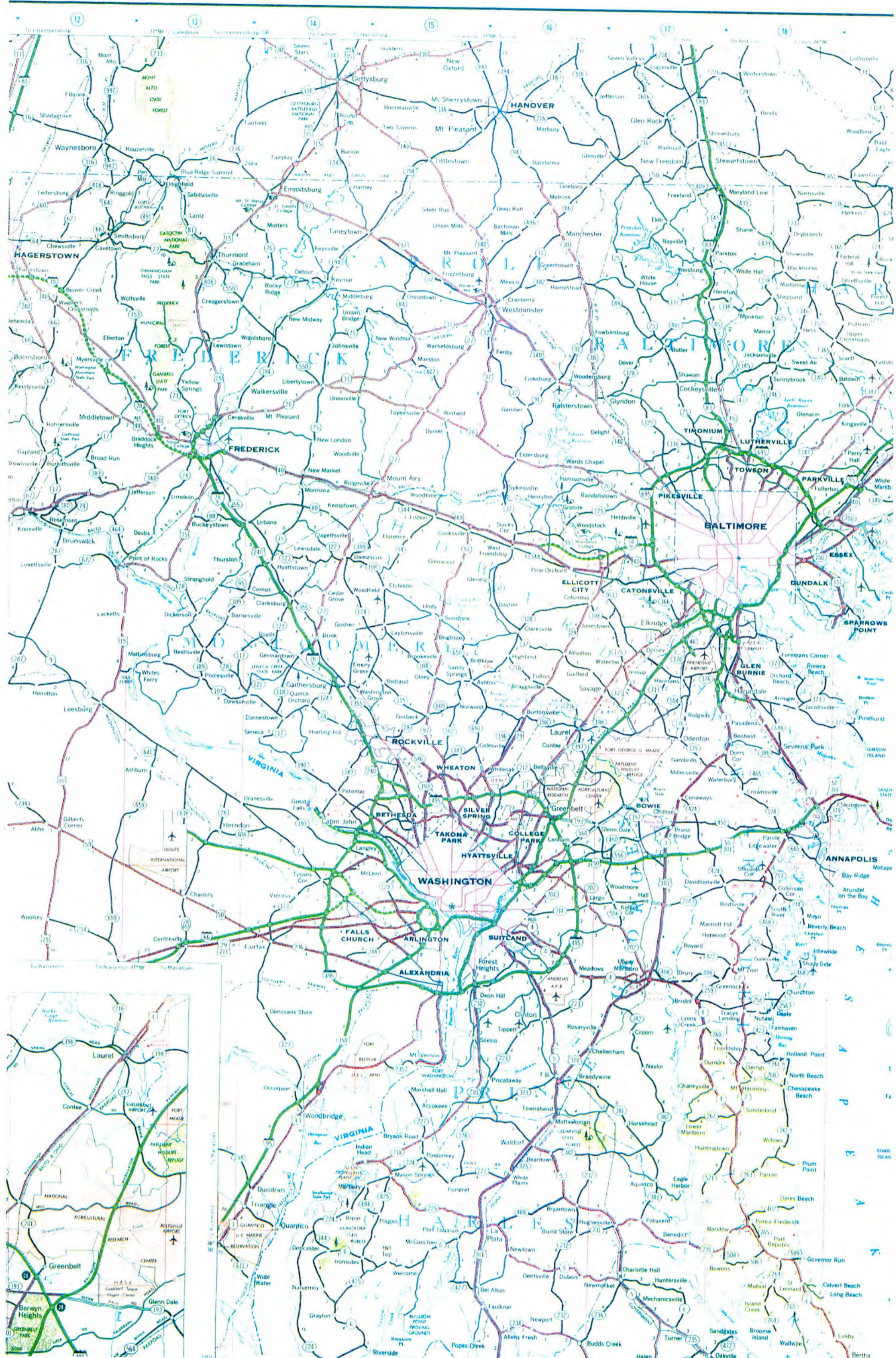

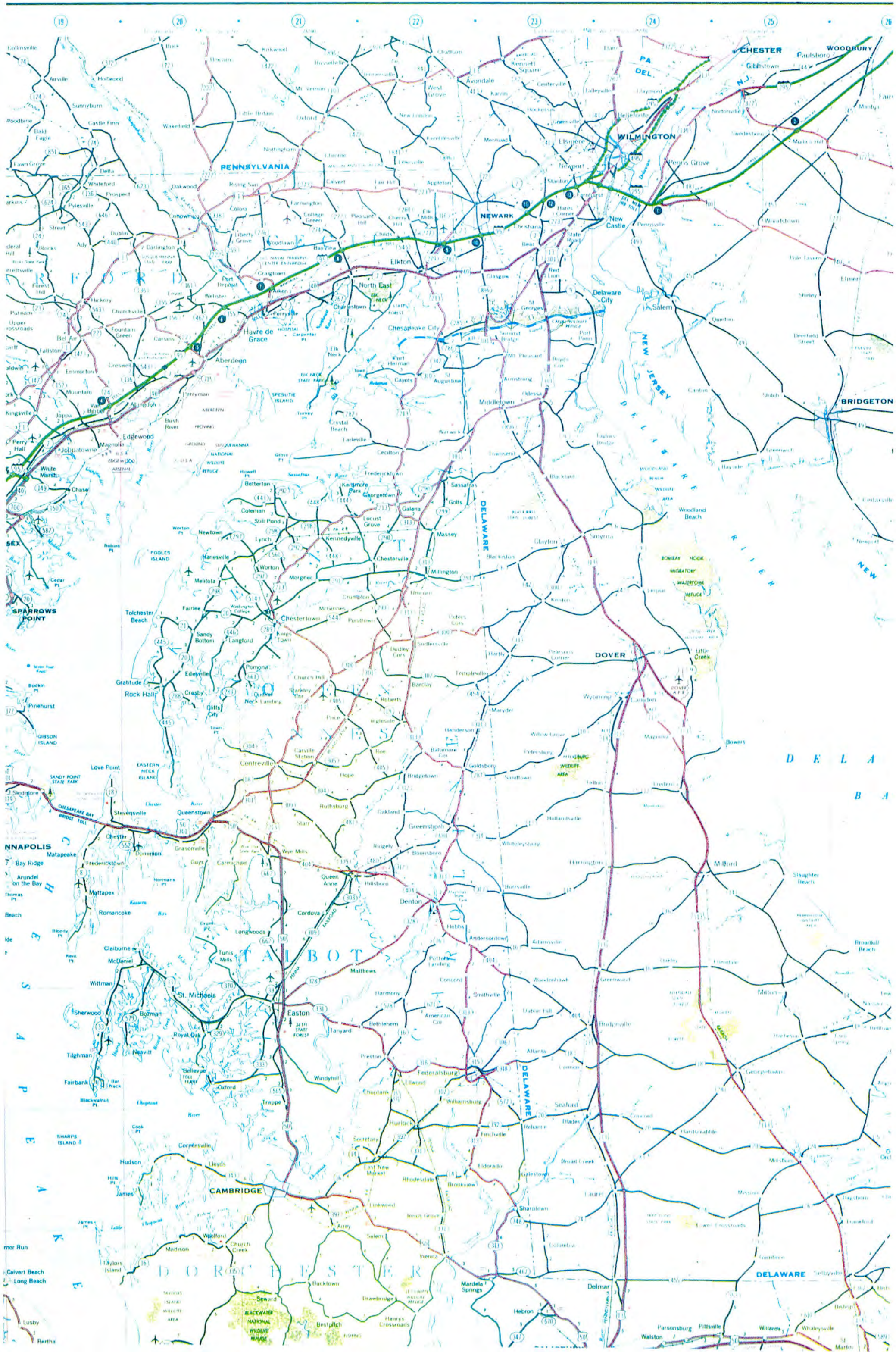

PENNSYLVANIA

WILMINGTON

NEWARK

CHESTER

WOODBURY

Havre de Grace

Chesapeake City

Delaware City

BRIDGETON

SPARROWS POINT

DOVER

DELAWARE

ANNAPOLIS

TALBOT

DELAWARE

CAMBRIDGE

DORCHESTER

DELAWARE

Seward

DELMAR

DELAWARE

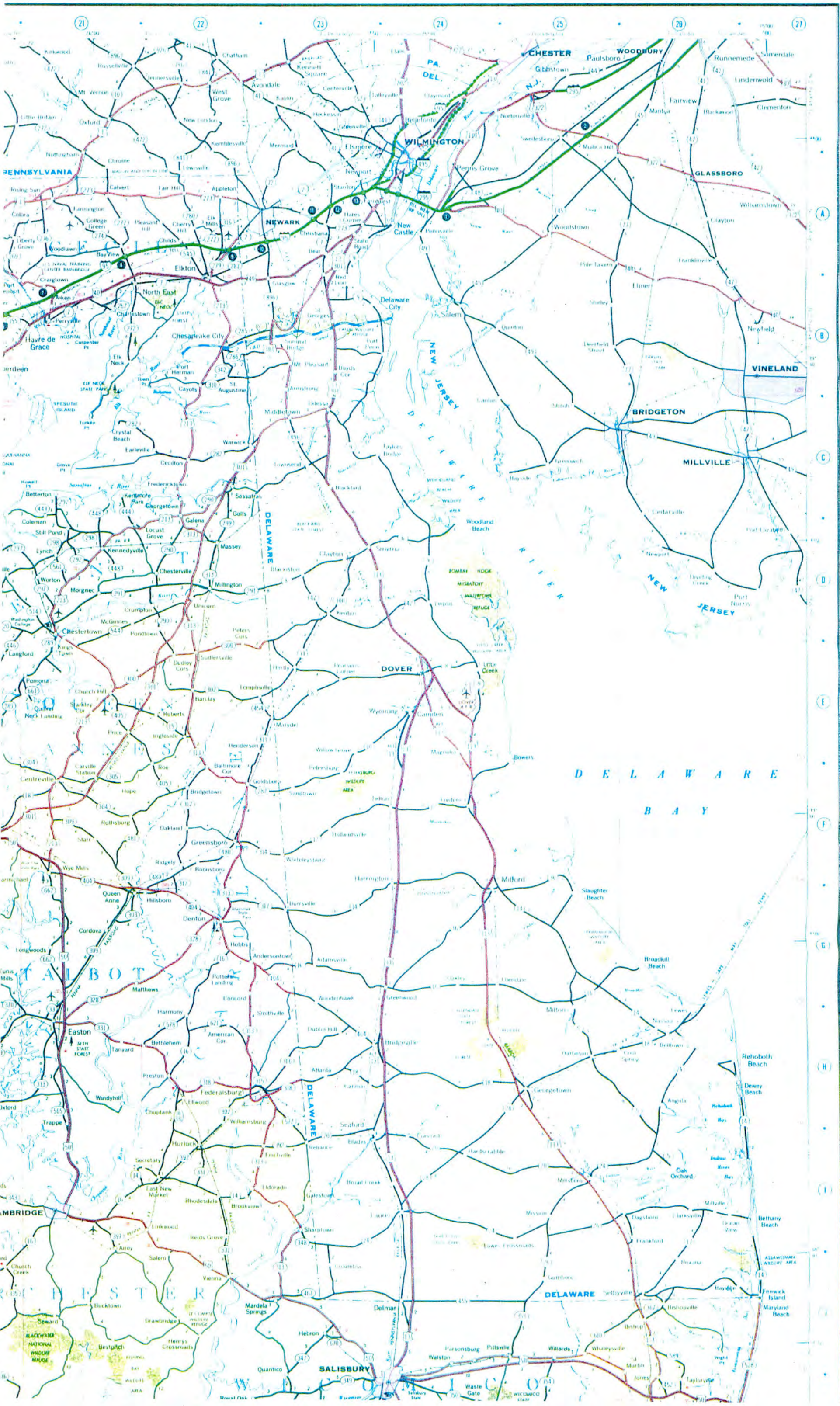

PENNSYLVANIA

MARYLAND

DELAWARE

DELAWARE BAY

WILMINGTON

NEWARK

DOVER

FEDERALSBURG

SALISBURY

CHESTER

WOODBURY

GLASSBORO

VINELAND

BRIDGETON

MILLVILLE

REHOBOTH BEACH

BETHANY BEACH

DELAWARE

DELAWARE

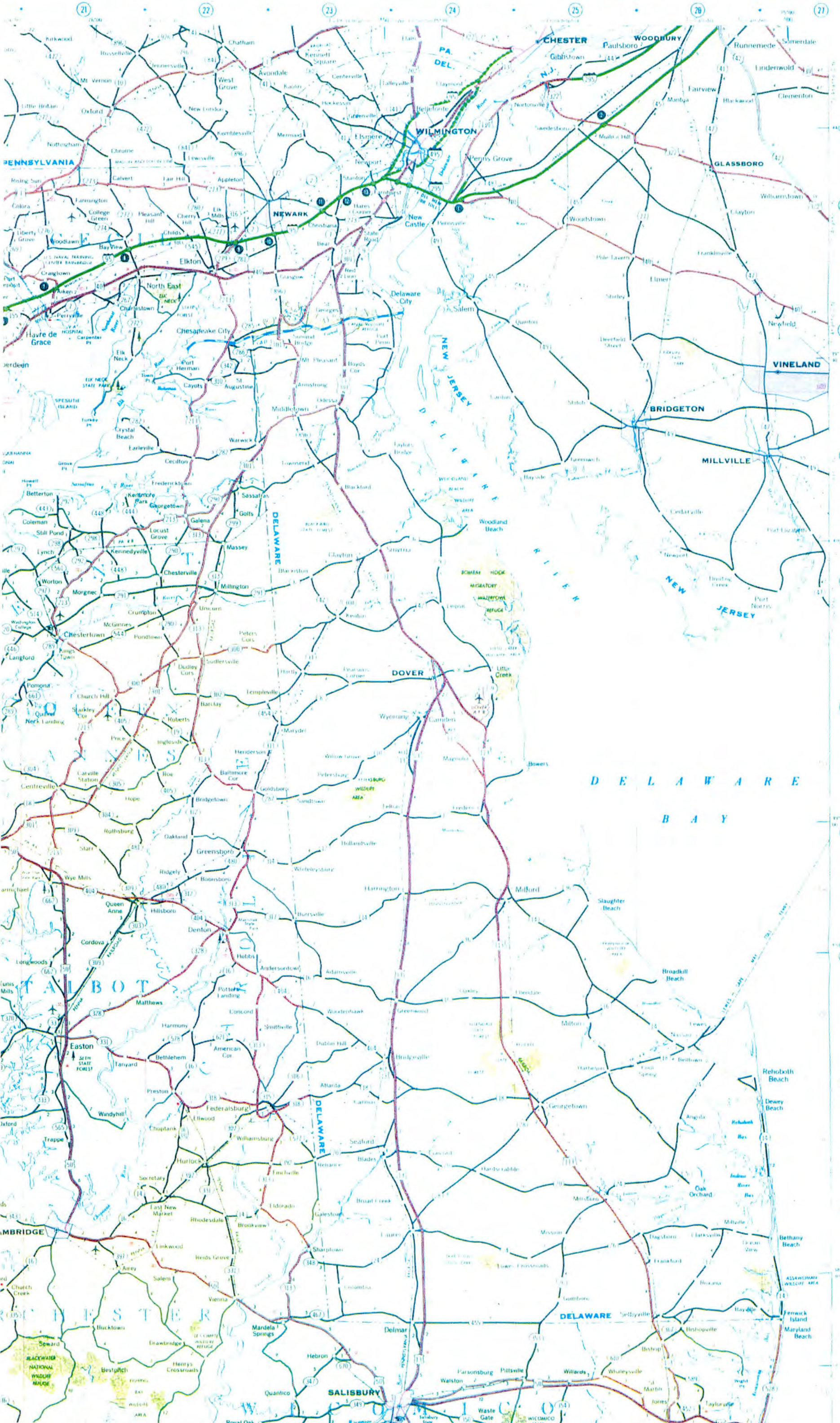

ATTACHMENT B: 1965 MARYLAND STATE ROAD MAP

Coles, Cor	H 16	Hobart	G 27	Park	I 17	Warrenton	B 15
Cowlesville	L 15	Hick Pt	I 19	Park Mar	J 15	Washington Grove	E 14
College Green	A 21	Hill Top	J 15	Perry Hall	E 15	Waste Lake	K 24
College Park	F 16	Hobbs	G 22	Perryville	C 20	Waterbury	F 18
Collington	F 17	Holland Point	H 18	Perryville	B 21	Waterloo	K 22
Colman-Cotter	F 18	Hollywood	H 18	Peters Corn	E 17	Watson Pt	N 22
Colmar Manor	F 16	Hoopa	H 20	Phelps Corner	G 16	Welder	B 20
Colore	A 21	Hooper Island	K 20	Pikeville	C 17	Wesburg	A 17
Colton	K 17	Hoopesville	F 21	Pine Knolls	E 19	Welcome	J 15
Columbia	D 16	Hopewell	M 22	Pine Orchard	F 14	Wellington	I 23
Concord	K 17	Horsehead	I 17	Pine Point	D 16	Wellston	I 22
Conus	D 14	Howell Pt	C 21	Piney Grove	A 11	Westley	I 25
Conawars	F 17	Hudson	B 2	Play Point	A 8	West Etidage	D 17
Concord	G 22	Hudson	I 20	Plum Pt	I 18	Westport	B 4
Conowingo	A 20	Humboldt Corner	M 23	Plum Pt	H 16	West Franchip	D 16
Conroy	E 16	Hughesville	H 17	Plum Pt	I 15	Westminster	B 16
Cook Pt	I 20	Hunterville	J 17	Pleasant Hill	A 22	Weyertown	D 12
Coonville	D 15	Hunting Hill	F 14	Plum Pt	I 18	Whalesville	D 12
Cortsville	I 20	Huntingtown	I 18	Plum Pt	M 24	Wharton	F 15
Cortland Pt	M 19	Hurlock	I 22	Point Ledge	M 19	Whitford	E 14
Cortrightville	A 5	Hutton	C 1	Point No. Point	I 19	White Hall	A 18
Cove Point	J 15	Hoyett	A 11	Point of Rocks	D 12	White Marsh	K 22
Craighton	B 21	Hyattsville	F 14	Pomona	E 21	White House	J 25
Cranberry	B 16	Hyattsville	D 16	Pomona	I 15	Whitehouse	F 23
Crago	K 21	I 1	I 1	Pomona	I 15	Whitehouse	F 23
Craigtown	B 13	I 1	I 1	Pomona	I 15	Whitehouse	F 23
Crescent	C 2	I 1	I 1	Pomona	I 15	Whitehouse	F 23
Crescent	B 5	I 1	I 1	Pomona	I 15	Whitehouse	F 23
Crescent	B 20	I 1	I 1	Pomona	I 15	Whitehouse	F 23
Crescent	M 22	I 1	I 1	Pomona	I 15	Whitehouse	F 23
Crochem	L 21	I 1	I 1	Pomona	I 15	Whitehouse	F 23
Crofton	F 17	I 1	I 1	Pomona	I 15	Whitehouse	F 23
Crook	H 17	I 1	I 1	Pomona	I 15	Whitehouse	F 23
Croody	E 20	I 1	I 1	Pomona	I 15	Whitehouse	F 23
Crowsville	F 18	I 1	I 1	Pomona	I 15	Whitehouse	F 23
Crumpton	D 22	I 1	I 1	Pomona	I 15	Whitehouse	F 23
Cystal Beach	C 18	I 1	I 1	Pomona	I 15	Whitehouse	F 23
Cut Hill	A 6	I 1	I 1	Pomona	I 15	Whitehouse	F 23
Cumberland	A 6	I 1	I 1	Pomona	I 15	Whitehouse	F 23

FEDERAL STATE AND MUNICIPAL RESERVATIONS

Abertons Trailing	C 20	Farmouth	M 22	Liberty Reservoir	F 18	Salt State Forest	H 21
Adams Air Force Base	F 16	Farmington	E 19	Lock River Reservoir	C 18	State Training School	J 9
Adams National Battlefield	C 12	Farmington	E 19	Martin National Wildlife Refuge	M 21	State Training School	J 9
Adams National Battlefield	C 12	Farmington	E 19	Martin National Wildlife Refuge	M 21	State Training School	J 9
Adams National Battlefield	C 12	Farmington	E 19	Martin National Wildlife Refuge	M 21	State Training School	J 9

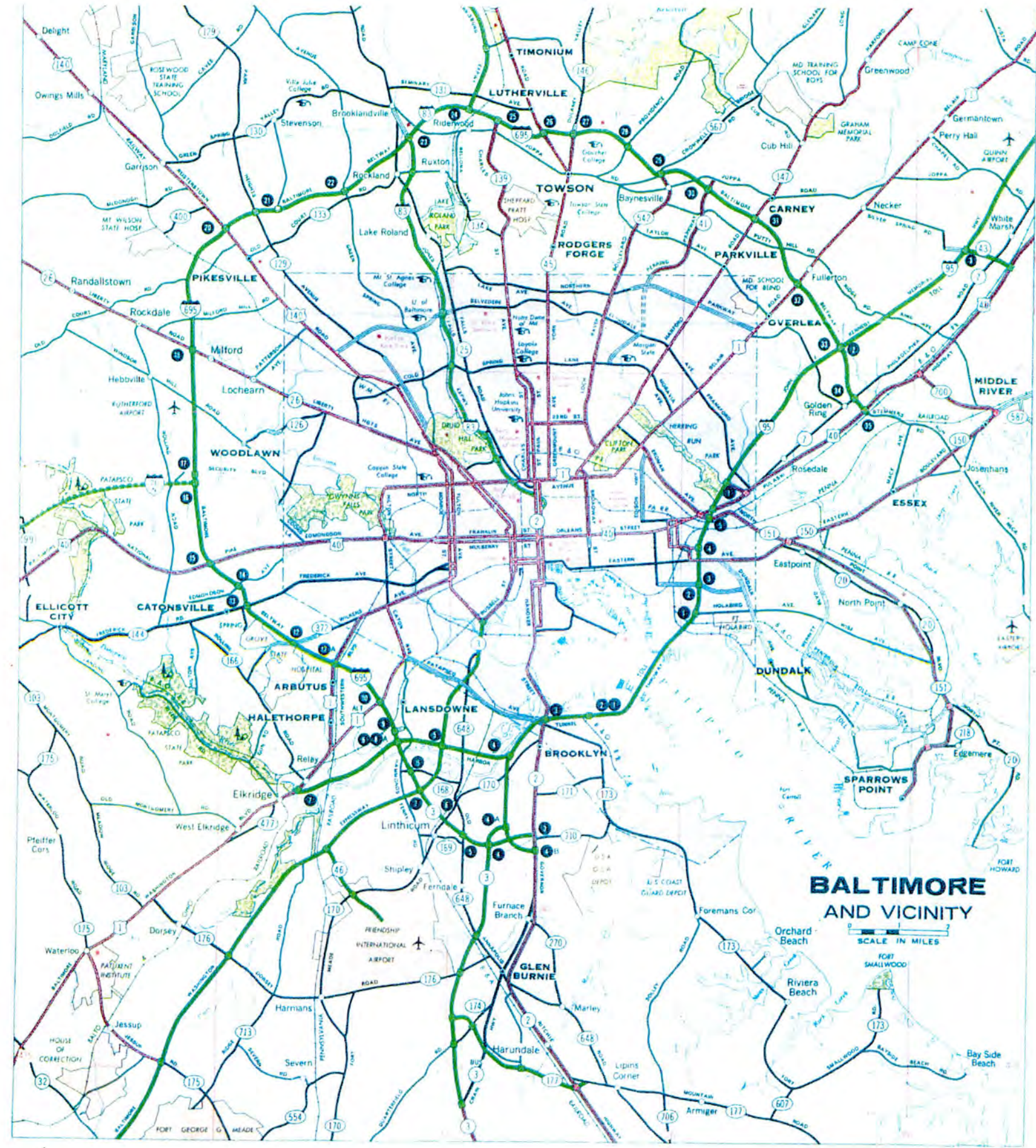

 Individual, Full Color County Maps of Maryland may be obtained at a nominal cost from the Planning and Programming Division, P.O. Box 717, Baltimore, Maryland 21203.

For all information about Maryland, write
 DEPARTMENT OF ECONOMIC DEVELOPMENT
 State Office Building
 Annapolis, Maryland

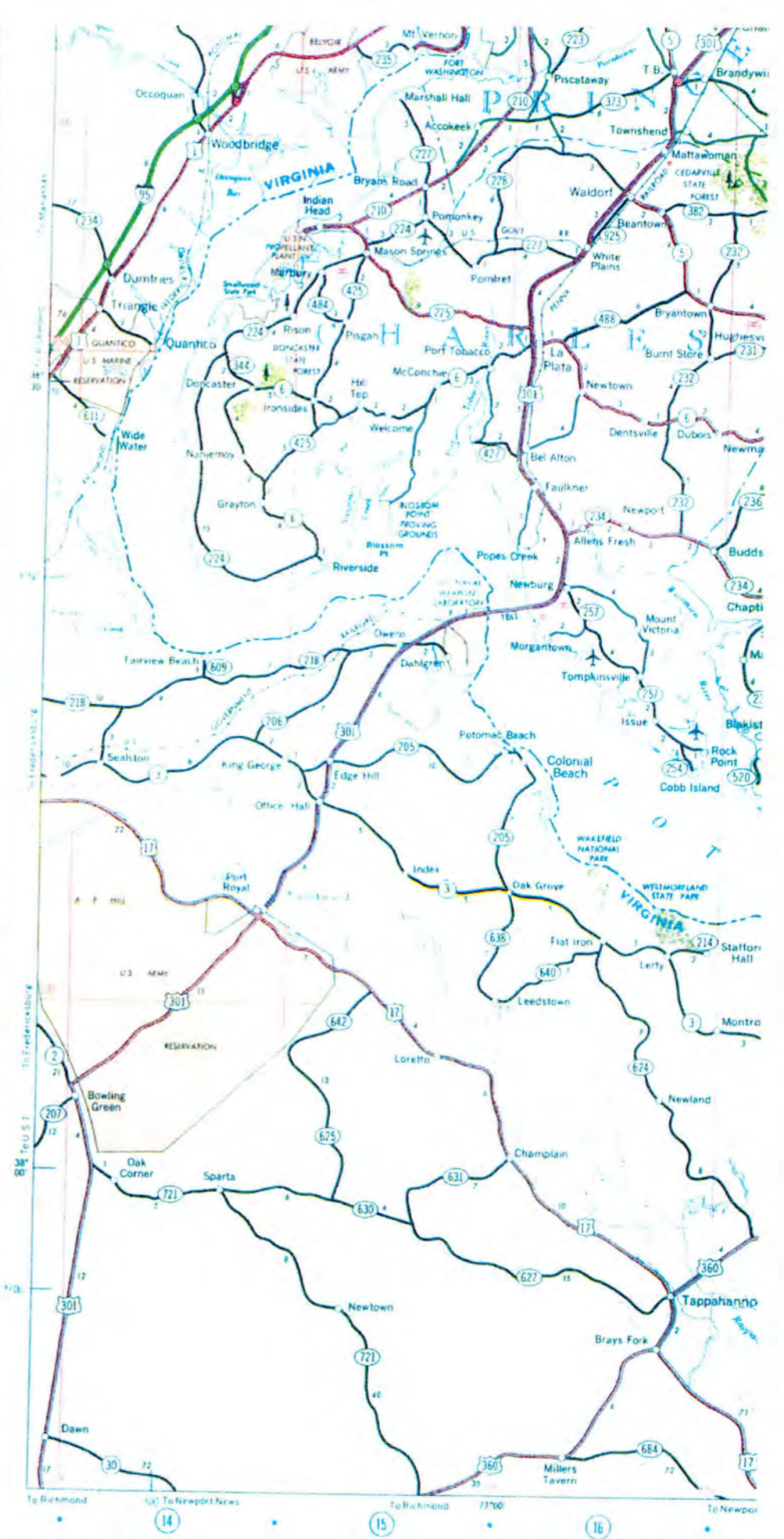
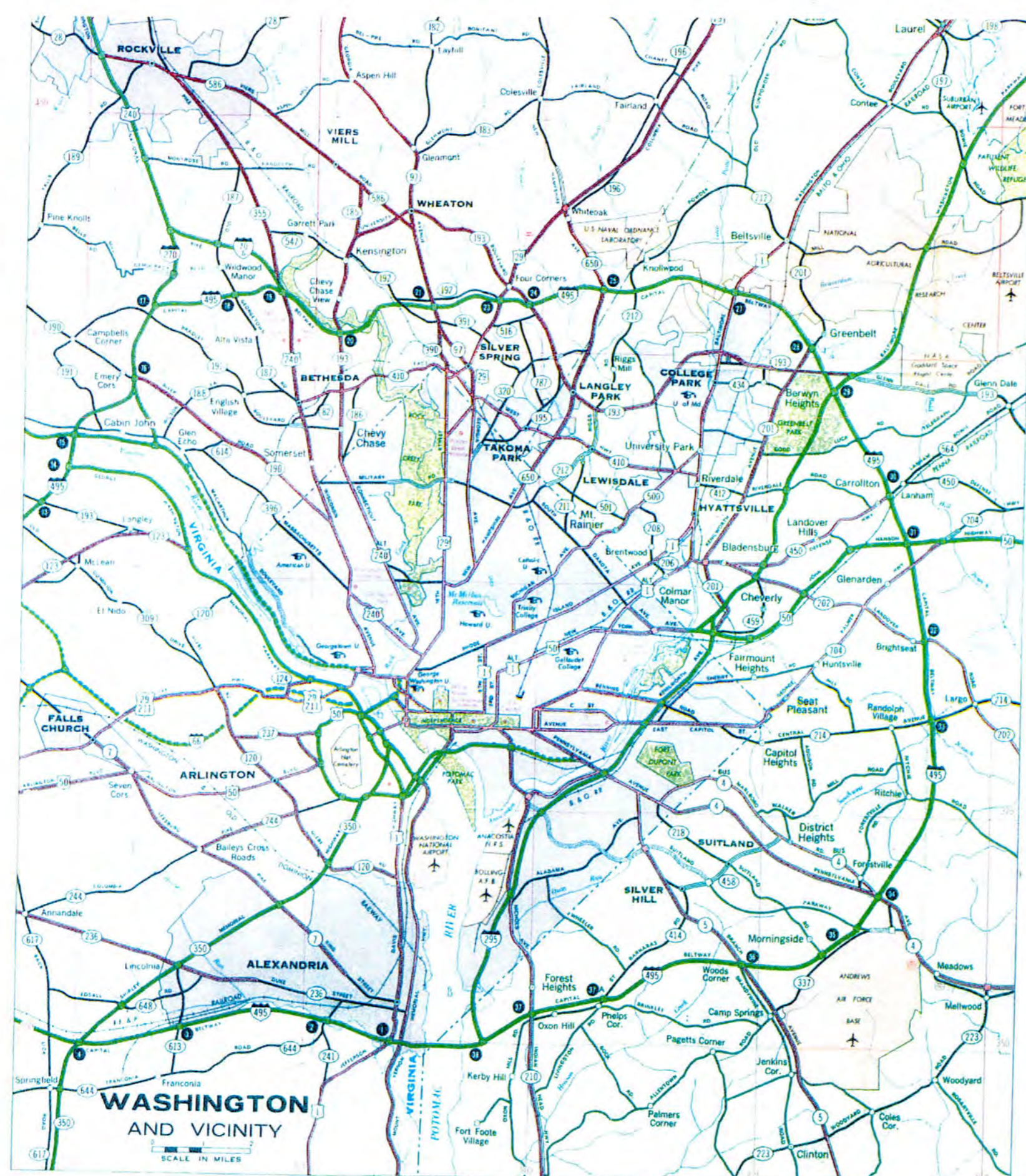
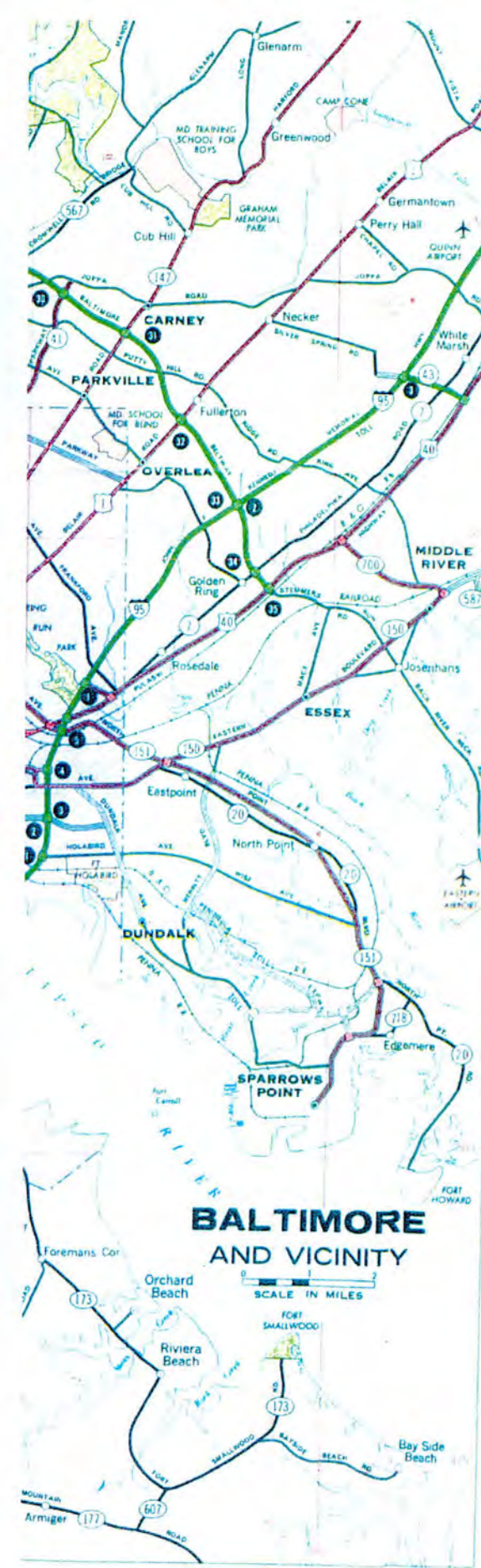

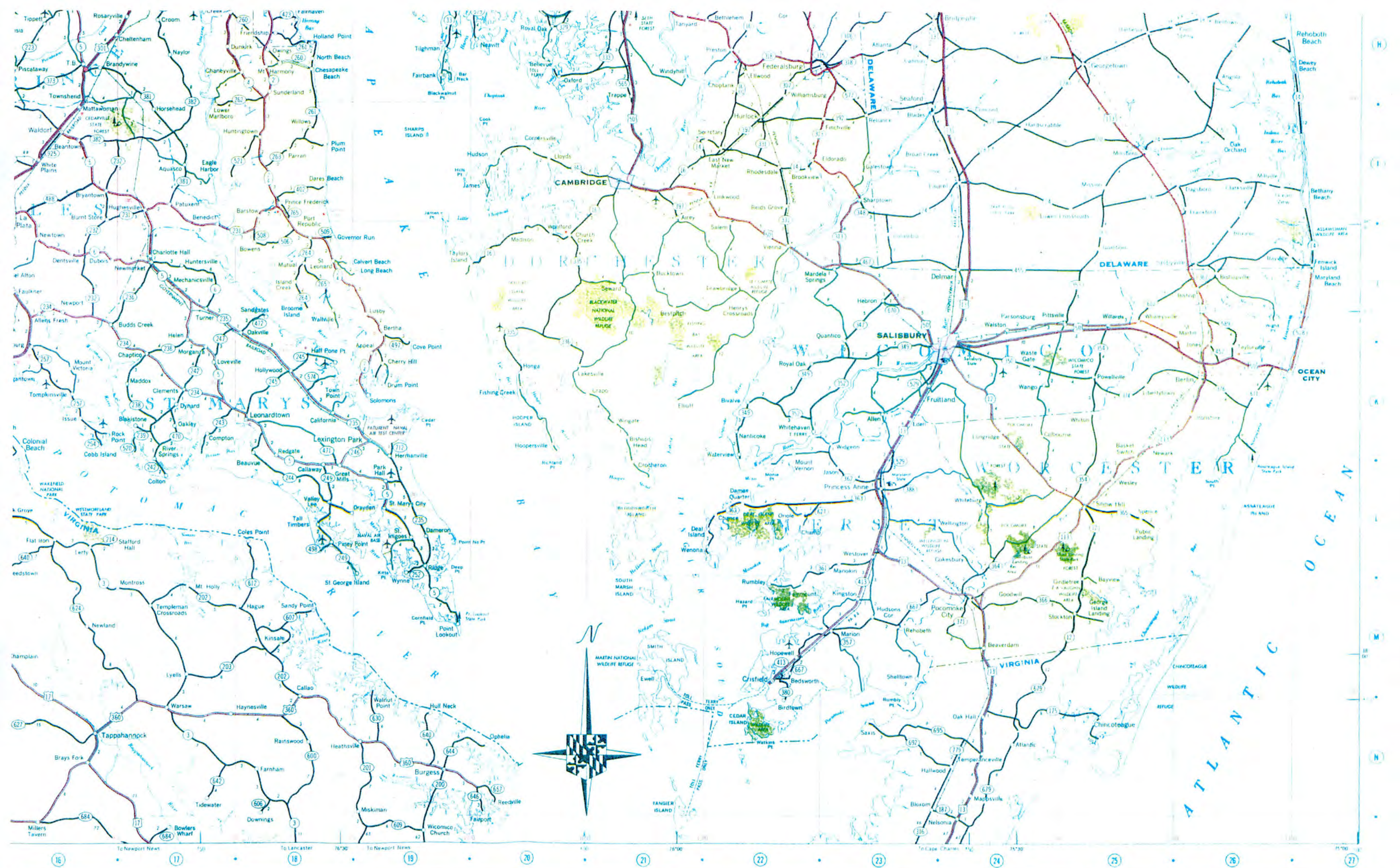

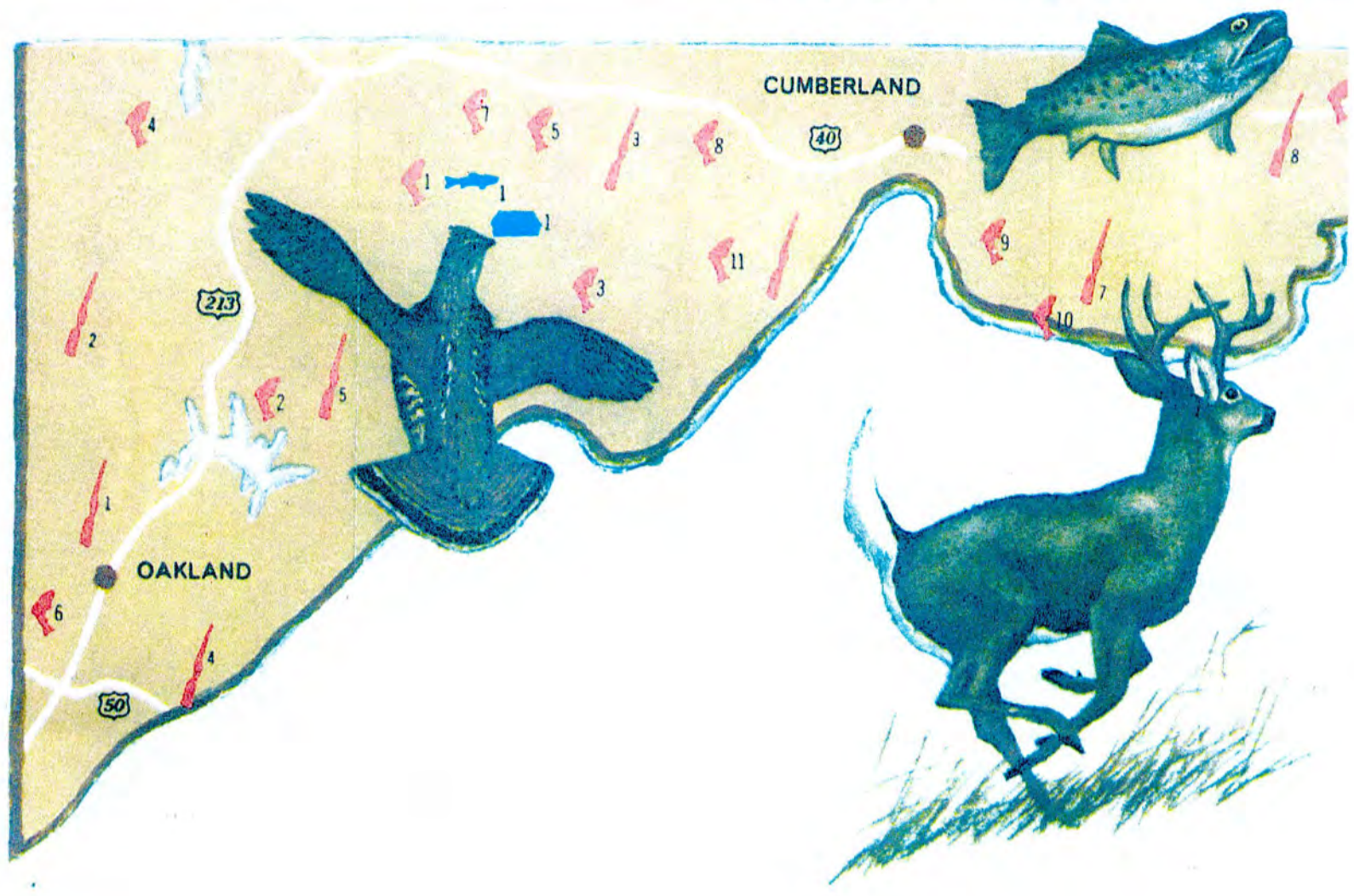

CANVASBACK

WILDLIFE

We thank Governor [Name] for his support of wildlife resources.

Prepared by Public Relations Division

Facilities and a numbers printed by using the lists

-  Public Hunting Lands
-  State Game Refuges

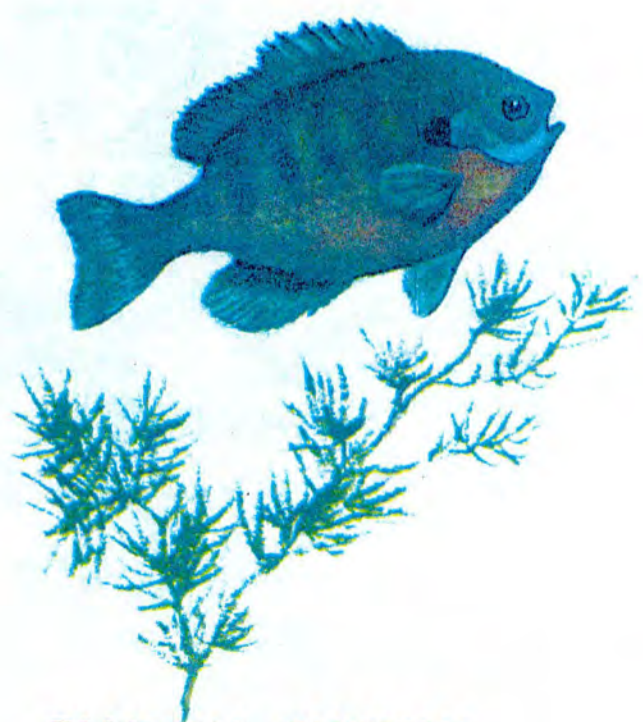

BLUEGILL SUNFISH

PUBLIC HUNTING LANDS		
Name of Property	Coordinates	
1. Mt. Nebo Wildlife Management Area Md. 219 near Oakland	130—595	13. Cedarville State Forest Brandywine
2. Swallow Falls State Forest 5 M. N.W. of Oakland	110—615	14. Doncaster State Forest Doncaster
3. Savage River State Forest 5 M. S. of Grantsville at New Germany	180—640	15. Myrtle Grove Wildlife Area Md. 225 near Ridge
4. Potomac State Forest Md. 560 near Kearney	160—560	16. Elk Neck State Forest Elkton
5. Meadow Mountain Recreation Area Off Md. 495 near Deep Creek Lake	160—625	17. Millington Wildlife Area Md. 291 near Millington
6. Dan's Mountain Wildlife Management Area Md. 220 near Rawlings	260—630	18. Linkwood Wildlife Area Md. 50 near Linkwood
7. Warrior Mountain Wildlife Management Area Off U. S. 40 near Twiggstown	345—650	19. Taylors Island Wildlife Management Area Md. 16 near Taylors Island
8. Green Ridge State Forest U. S. 40 near Flintstone	370—650	20. Fishing Bay Wildlife Area Near Bestpitch—
9. Sidling Hill Wildlife Management Area Md. 453 near Pearre	425—660	21. Ellis Bay Wildlife Management Area Md. 352 to Whitehaven
10. Indian Springs Wildlife Management Area U. S. 40 near Indian Springs	515—680	22. Cedar Island Wildlife Area Md. 413 to Crist
		23. Deal Island Wildlife Area Md. 363 to Dame
		24. Edgewater Wildlife Area Md. 402 to Edgewater

facilities and areas can be located on this map by appropriate symbols and numbers printed in red and blue. Exact locations are given on the reverse side by using the listed coordinate numbers which are printed in red on the map edges.



BLUEGILL SUNFISH



LEGEND



Name of Property	Coordinates
1. Mt. Nebo Wildlife Management Area Md. 219 near Oakland	130—595
2. Swallow Falls State Forest 5 M. N.W. of Oakland	110—615
3. Savage River State Forest 5 M. S. of Grantsville at New Germany	180—640
4. Potomac State Forest Md. 560 near Kearney	160—560
5. Meadow Mountain Recreation Area Off Md. 495 near Deep Creek Lake	160—625
6. Dan's Mountain Wildlife Management Area Md. 220 near Rawlings	260—630
7. Warrior Mountain Wildlife Management Area Off U. S. 40 near Twiggstown	345—650
8. Green Ridge State Forest U. S. 40 near Flintstone	370—650
9. Sidling Hill Wildlife Management Area Md. 453 near Pearre	425—660
10. Indian Springs Wildlife Management Area U. S. 40 near Indian Springs	515—680
11. South Mountain Watershed Area Top of South Mountain 1/2 mile strip between Washington & Frederick Counties extending from Potomac River to Mason-Dixon Line	
12. Cunningham Falls State Area Md. 77 near Thurmont	675—645

PUBLIC HUNTING LANDS

13. Cedarville State Forest Md. 381 near Brandywine	850—294
14. Doncaster State Forest Md. 6 at Doncaster	743—246
15. Myrtle Grove Wildlife Management Area Md. 225 near Ripley	775—260
16. Elk Neck State Forest Md. 7 near Elkton	1110—640
17. Millington Wildlife Management Area Md. 291 near Millington	1145—530
18. Linkwood Wildlife Management Area Md. 50 near Linkwood	1105—260
19. Taylors Island Wildlife Management Area Md. 16 from Cambridge	1010—220
20. Fishing Bay Wildlife Management Area Near Bestpitch—S.W. Vienna	1085—215
21. Ellis Bay Wildlife Management Area Md. 352 to Whitehaven	1145—160
22. Cedar Island Wildlife Management Area Md. 413 to Crisfield	1125—40
23. Deal Island Wildlife Management Area Md. 363 to Dames Quarter	1130—130
24. Fairmount Wildlife Management Area Md. 361 to Fairmount	1140—95
25. Wellington Wildlife Management Area Dublin Road near Kings Creek	1195—120
26. Sinepuxent Bay Wildlife Management Area Small Islands in Sinepuxent Bay	1340—170
27. Pocomoke State Forest U. S. 313 between Pocomoke City & Snow Hill	1225—140

STATE GAME REFUGES

1. Billmeyer Wildlife Refuge U. S. 40 near Piney Grove	400—685
2. McKee—Beshers Wildlife Refuge Off Md. 107 on Sycamore Landing Road	680—455
3. Dierssen Waterfowl Sanctuary Off Md. 190 at Pennyfield Locks	725—440
4. Strider Conservation Center Off Md. 118 near Germantown	725—485
5. Hugg-Thomas Wildlife Refuge Md. 32 at Sykesville	810—555
6. Harry Bowen Wildlife Refuge Md. 381 at Aquasco	890—270
7. Blackiston Island Refuge & Historical Monument Md. 242—1/2 M. off shore near Colton	875—140
8. Gwynnbrook Wildlife Refuge Off Md. 140 near Owings Mills	865—580
9. Cecil Wildlife Refuge Off U. S. 40 near Elkton	1140—650
10. Idylwild Wildlife Refuge Md. 306 at Federalburg	1155—320
11. LeCompte Wildlife Refuge Off U. S. 50 S. of Vienna	1120—230
12. Pocomoke Sound Wildlife Refuge Md. 357 S. of Marion	1155—60
13. Johnson Wildlife Refuge Off Md. 12 E. of Salisbury	1225—180
14. Girdletree Wildlife Refuge Md. 12 near Girdletree	1260—90

GAME FARM

1. Belle Grove Game Farm U. S. at Belle Grove
2. Girdletree Game Farm Md. 1 Girdletree

FISH HATCHERIES AND REARINGS

1. Bear Creek Fish Rearing Md. 219 near Accident
2. Beaver Creek Fish Hatchery U. S. 40 on Md. 66
3. Lewistown Fish Rearing Station U. S. 15 near Lewistown
4. Cecil Fish Rearing Station Off U. S. 40 near Elkton

WORK CENTERS

1. Bear Creek Work Center Md. near Accident
2. Lewistown Work Center Off U. S. 15 near Lewistown
3. Gwynnbrook Work Center Off U. S. 140 near Owings Mills
4. Fallston Work Center Off U. S. on Md. 147
5. Elkton Work Center Off U. S. at Elkton
6. Wye Mills Work Center Off U. S. 50 at Wye Mills
7. Johnson Work Center Off Md. of Salisbury



RACCOON



MUSKRAT



WOODCOCK



WILDLIFE RESOURCES of MARYLAND

We thank Governor J. Millard Tawes and the State Roads Commission for their interest in our wildlife resources and particularly for making available this side of the 1965 map for our use.

Prepared by Public Relations Division: Malcolm E. King, Chief

George B. Shields, Jr.
George B. Shields, Jr.
Maryland Game & Inland Fish Commission

Map Reading Guide

Facilities and areas can be located on this map by appropriate symbols and numbers printed in red and blue. Exact locations are given on the reverse side by using the listed coordinate numbers which are printed in red on the map edges.



Public Hunting Lands



State Game Refuges

LEGEND

 Work Centers

 Game Farms

 Boat Launching Ramps

 Fish I

 Lakes

PUBLIC HUNTING LANDS

Name of Property	Coordinates
1. Mt. Nebo Wildlife Management Area Md. 219 near Oakland	130—595
2. Swallow Falls State Forest 5 M. N.W. of Oakland	110—615
3. Savage River State Forest 5 M. S. of Grantsville at New Germany	180—640
4. Potomac State Forest Md. 560 near Kearney	160—560
5. Meadow Mountain Recreation Area Off Md. 495 near Deep Creek Lake	160—625
6. Dan's Mountain Wildlife Management Area Md. 220 near Rawlings	260—630
7. Warrior Mountain Wildlife Management Area Off U. S. 40 near Twiggstown	345—650
8. Green Ridge State Forest U. S. 40 near Flintstone	370—650
9. Sidling Hill Wildlife Management Area Md. 453 near Pearre	425—660
10. Indian Springs Wildlife Management Area U. S. 40 near Indian	515—680

Name of Property	Coordinates
13. Cedarville State Forest Md. 381 near Brandywine	850—294
14. Doncaster State Forest Md. 6 at Doncaster	743—246
15. Myrtle Grove Wildlife Management Area Md. 225 near Ripley	775—260
16. Elk Neck State Forest Md. 7 near Elkton	1110—640
17. Millington Wildlife Management Area Md. 291 near Millington	1145—530
18. Linkwood Wildlife Management Area Md. 50 near Linkwood	1105—260
19. Taylors Island Wildlife Management Area Md. 16 from Cambridge	1010—220
20. Fishing Bay Wildlife Management Area Near Bestpitch—S.W. Vienna	1085—215
21. Ellis Bay Wildlife Management Area Md. 352 to Whitehaven	1145—160
22. Cedar Island Wildlife Management Area Md. 413 to Crisfield	1125—40
23. Deal Island Wildlife Management Area Md. 363 to Dames Quarter	1130—130

STATE GAME REFUGES

1. Billmeyer Wildlife Refuge U. S. 40 near Piney Grove
2. McKee-Beshers Wildlife Refuge Off Md. 107 on Sycamore Landing Road
3. Dierksen Waterfowl Sanctuary Off Md. 190 at Pennyfield Locks
4. Strider Conservation Center Off Md. 118 near Germantown
5. Hugg-Thomas Wildlife Refuge Md. 32 at Sykesville
6. Harry Bowen Wildlife Refuge Md. 381 at Aquasco
7. Blackiston Island Refuge & Historical Monument Md. 242—1/2 M. off shore near Colton
8. Gwynnbrook Wildlife Refuge Off Md. 140 near Owings Mills
9. Cecil Wildlife Refuge Off U. S. 40 near Elkton
10. Idylwild Wildlife Refuge Md. 306 at Federalsburg
11. LaCombe Wildlife Refuge Off U. S.



ASBACK



SUNFISH



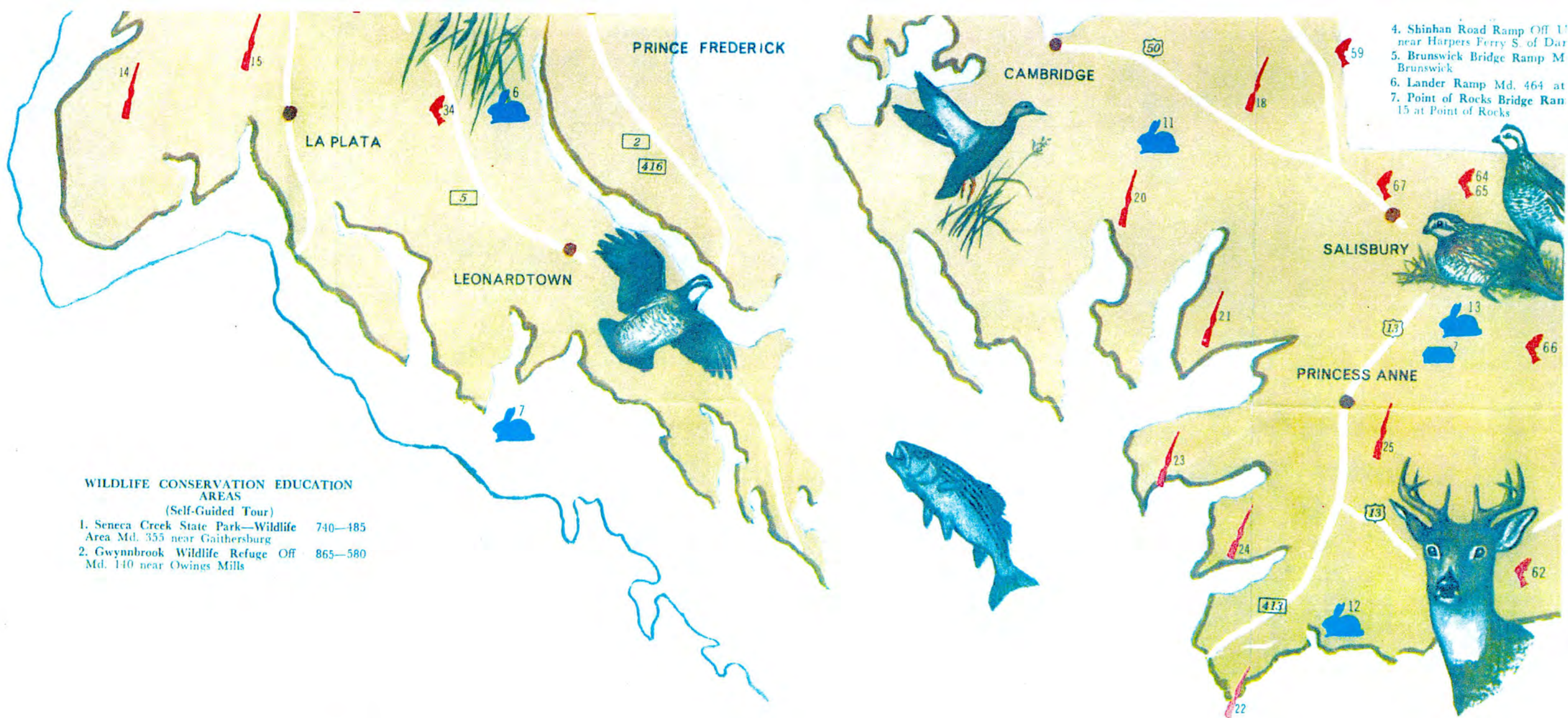

4. Shinhan Road Ramp Off U.S. 50 near Harpers Ferry S. of Dar.
5. Brunswick Bridge Ramp Md. 13 near Brunswick.
6. Lander Ramp Md. 464 at Point of Rocks.
7. Point of Rocks Bridge Ramp Md. 15 at Point of Rocks.
8. ...
9. ...
10. ...
11. ...
12. ...
13. ...
14. ...
15. ...
16. ...
17. ...
18. ...
19. ...
20. ...
21. ...
22. ...
23. ...
24. ...
25. ...

- GAME FARMS**
- Game Farm U. S. 40 415-680
 - Game Farm Md. 12 near 1260-90
- RIES AND REARING STATIONS**
- Fish Rearing Station 150-665
 - Accident
 - ek Fish Hatchery Off 620-610
 - Id. 66
 - ish Rearing Station Off 685-620
 - r Lewistown
 - earing Station Off U. S. 1140-650
 - n
- WORK CENTERS**
- Work Center Md. 219 150-665
 - Work Center Off U. S. 685-620
 - town
 - Work Center Off Md. 865-580
 - ngs Mills
 - rk Center Off U. S. 1 970-610
 - k Center Off U. S. 40 1140-650
 - Work Center Off U. S. 1060-410
 - ills
 - rk Center Off Md. 12 E. 1225-180

- WILDLIFE CONSERVATION EDUCATION AREAS**
(Self-Guided Tour)
1. Seneca Creek State Park—Wildlife Area Md. 355 near Gaithersburg 740-485
 2. Gwynnbrook Wildlife Refuge Off Md. 140 near Owings Mills 865-580



WOODCHUCK

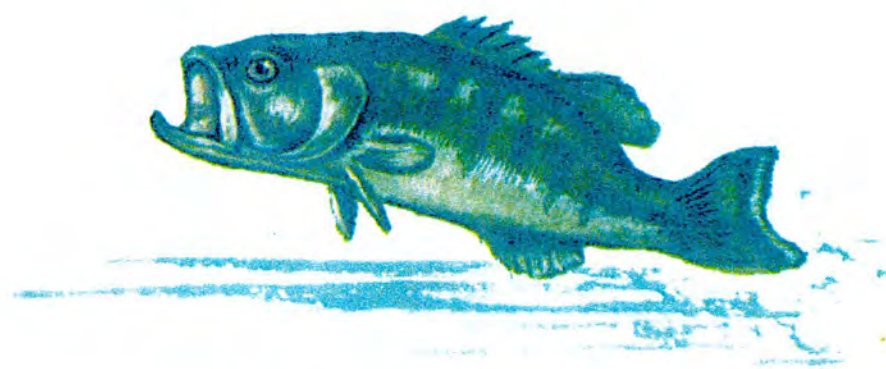

SMALLMOUTH BASS



BEAVER

URCES

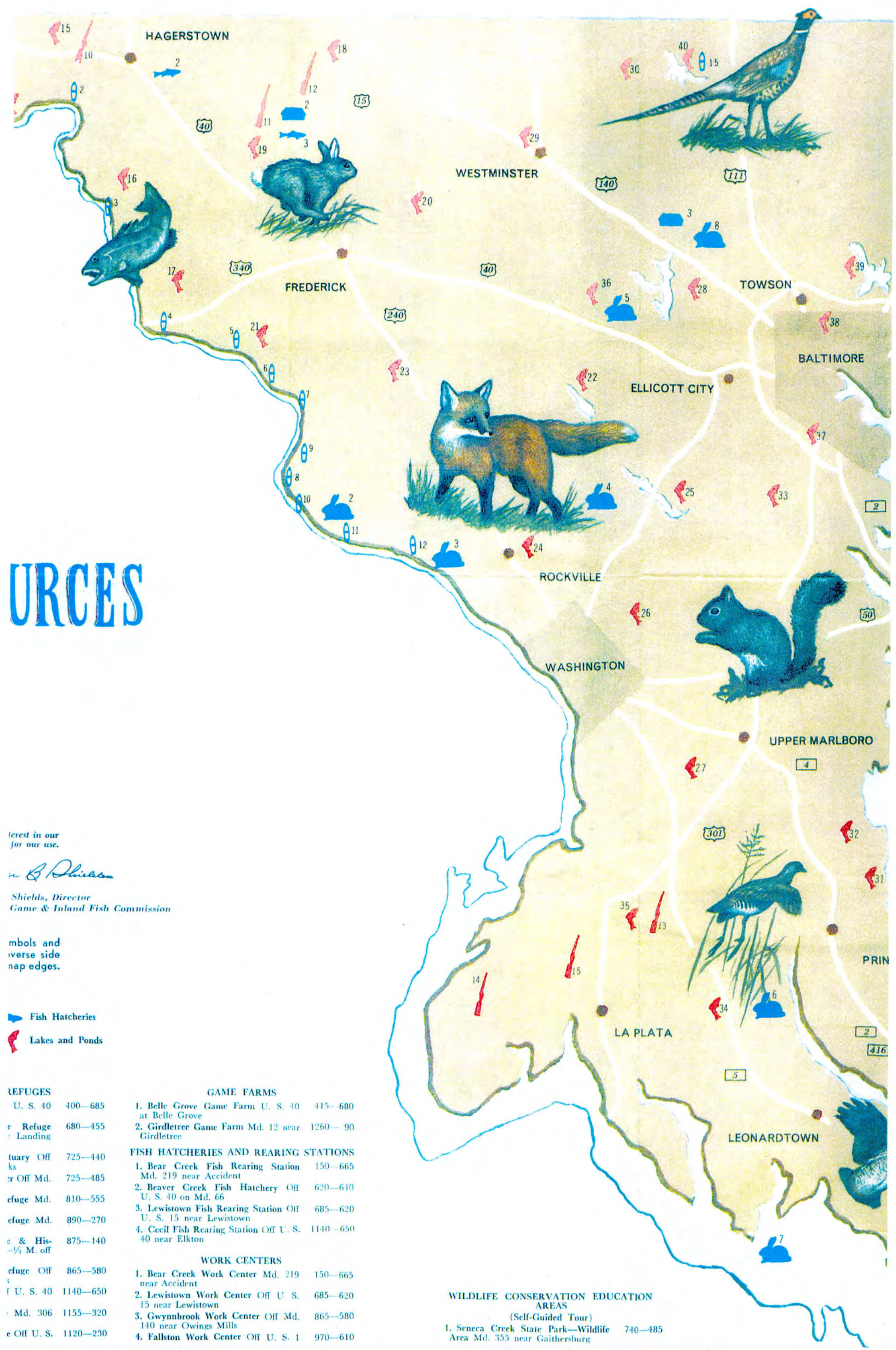

Interest in our
for our use.

B. Shields
Shields, Director
Game & Inland Fish Commission

Symbols and
reverse side
map edges.

Fish Hatcheries
 Lakes and Ponds

REFUGES

U. S. 40	400—685
Refuge	680—455
Landing	
Quary Off	725—440
er Off Md.	725—485
efuge Md.	810—555
efuge Md.	890—270
e & His- -1/2 M. off	875—140
efuge Off	865—580
f U. S. 40	1140—650
Md. 306	1155—320
e Off U. S.	1120—230

GAME FARMS

1. Belle Grove Game Farm U. S. 40	415—680
2. Girdletree Game Farm Md. 12 near Girdletree	1260—90

FISH HATCHERIES AND REARING STATIONS

1. Bear Creek Fish Rearing Station Md. 219 near Accident	150—665
2. Beaver Creek Fish Hatchery Off U. S. 40 on Md. 66	620—610
3. Lewistown Fish Rearing Station Off U. S. 15 near Lewistown	685—620
4. Cecil Fish Rearing Station Off U. S. 40 near Elkton	1140—650

WORK CENTERS

1. Bear Creek Work Center Md. 219 near Accident	150—665
2. Lewistown Work Center Off U. S. 15 near Lewistown	685—620
3. Gwynnbrook Work Center Off Md. 140 near Owings Mills	865—580
4. Fallston Work Center Off U. S. 1	970—610

WILDLIFE CONSERVATION EDUCATION AREAS (Self-Guided Tour)

1. Seneca Creek State Park—Wildlife Area Md. 355 near Gaithersburg	740—485
--	---------

LAKES AND PONDS OPEN TO PUBLIC FISHING

Name of Property	Acres	Coordinates	
1. Accident Community Pond U. S. 219—Accident	1	145—660	34. Hugl Md. 5
2. Deep Creek Lake* U. S. 219—McHenry	3900	150—620	35. Ceda U. S.
3. Savage Reservoir Md. 135—4 M. N.W. of Bloomington	350	200—620	36. Gwy Pond Owing
4. Youghiogheny Reservoir Md. 42—2 M. N. of Friendsville	800	125—690	37. Hills Lansdo
5. Pleasant Valley Lake Md. 495—12 M. S. of Grantsville	18	165—635	38. Lake Baltin
6. Herrington Lake U. S. 219—5 M. N. of Oakland	44	110—590	39. Locl 146
7. New Germany Lake U. S. 40—6 M. S. of Grantsville	10	205—630	40. Pret 25 an Rd.
8. Piney Reservoir Md. 546—8 M. W. of Frostburg	18	225—695	41. Atk near
9. Evitts Creek Community Pond U. S. 40—4 M. E. of Cumberland	4	315—670	42. Byn Pond
10. Battie Mixon Fishing Hole Md. 51—at Oldtown	33	345—630	43. For Md.
11. Dan's Mountain Pond Md. 36—2 M. E. of Lonaconing	1	240—665	44. Cor at Co
12. White Sulphur Community Pond U. S. 40—Greenridge State Forest, 12 M. E. of Flintstone	1	390—675	45. Ris U. S.
13. Little Pool U. S. 40—3 M. S.W. of Hancock	31	470—680	46. Elk 7 at
14. Big Pool U. S. 40—6 M. S.W. of Clearspring at Fort Frederick	88	515—650	47. Phu 40 n
15. Indian Springs Community Pond Md. 56—8 M. W. of Clearspring	1.3	510—680	48. Bac near
16. Sharpsburg Community Pond Md. 65 at Sharpsburg	1.2	590—590	49. Fri Ceci
17. Brownsville Community Pond Md. 67 at Brownsville	1.2	610—575	50. Ste near
18. Frank Bentz Memorial Pond Md. 77 East of Thurmont	2	680—655	51. Ur U. 1
19. Gambrill's Community Pond U. S. 40 near Frederick	1	660—590	52. St. Fair
20. Libertytown Community Pond Md. 75 at Libertytown	1	730—600	53. W Off
21. Brunswick Community Pond U. S. 79 at Brunswick	1	630—550	54. Ur Md.
22. Tridelfia Reservoir* off Md. 650 near Brighton at Dam	800	695—495	55. Sn Off
23. Kings Community Pond U. S. 355 and Md. 121—Clarksburg	1	730—525	56. G. Den
24. Gaithersburg Community Pond U. S. 365 near Gaithersburg	1.3	730—490	57. Li Pre
25. Rocky Gorge Reservoir* Md. 198 and U. S. 29—Burtonsville	300	820—470	58. C Fed
26. Greenbelt Lake Md. 564 at Greenbelt	22	830—435	59. G Gal
27. Melwood Community Pond Md. 5—Woodyard	1.3	850—355	60. B U
28. Liberty Reservoir* Md. 26 near Ward's Chapel	3100	830—565	61. T Oe
29. Westminster Community Pond U. S. 140 at Westminster	1.3	800—640	62. M nea
30. North Carroll Community Pond Md. 30 at Manchester	1.2	830—670	63. B Mc
31. Mt. Harmony Pond Md. 2 at Harmony	2.3	915—325	64. I of
32. Friendship Community Pond Md. 2, at Friendship	1	915—330	65. J Sal
33. Patuxent Ponds U. S. 301 at Conaways	3.2	875—435	66. S Sal
			67. T bu
			68. I at

* Indicates locations with boat

BOAT LAUNCHING

Non-Tidal Water

(In addition to those listed)

1. C & O Canal Four Locks Ramp Off Md. 56 near Big Spring	540—655	8. C Of
2. Williamsport River Front Ramp Md. 68 at Williamsport	565—650	9. M Me
3. Shepherdstown Bridge Ramp Md. 34 W. of Sharpsburg	575—585	10. A WI
4. Shinhan Road Ramp Off U. S. 340 near Harpers Ferry S. of Dargan	595—555	11. I S.V
5. Brunswick Bridge Ramp Md. 79 at Brunswick	625—540	12. S an
6. Lander Ramp Md. 464 at Lander	640—540	13. C of
7. Point of Rocks Bridge Ramp U. S. 15 at Point of Rocks	650—525	14. I Pe

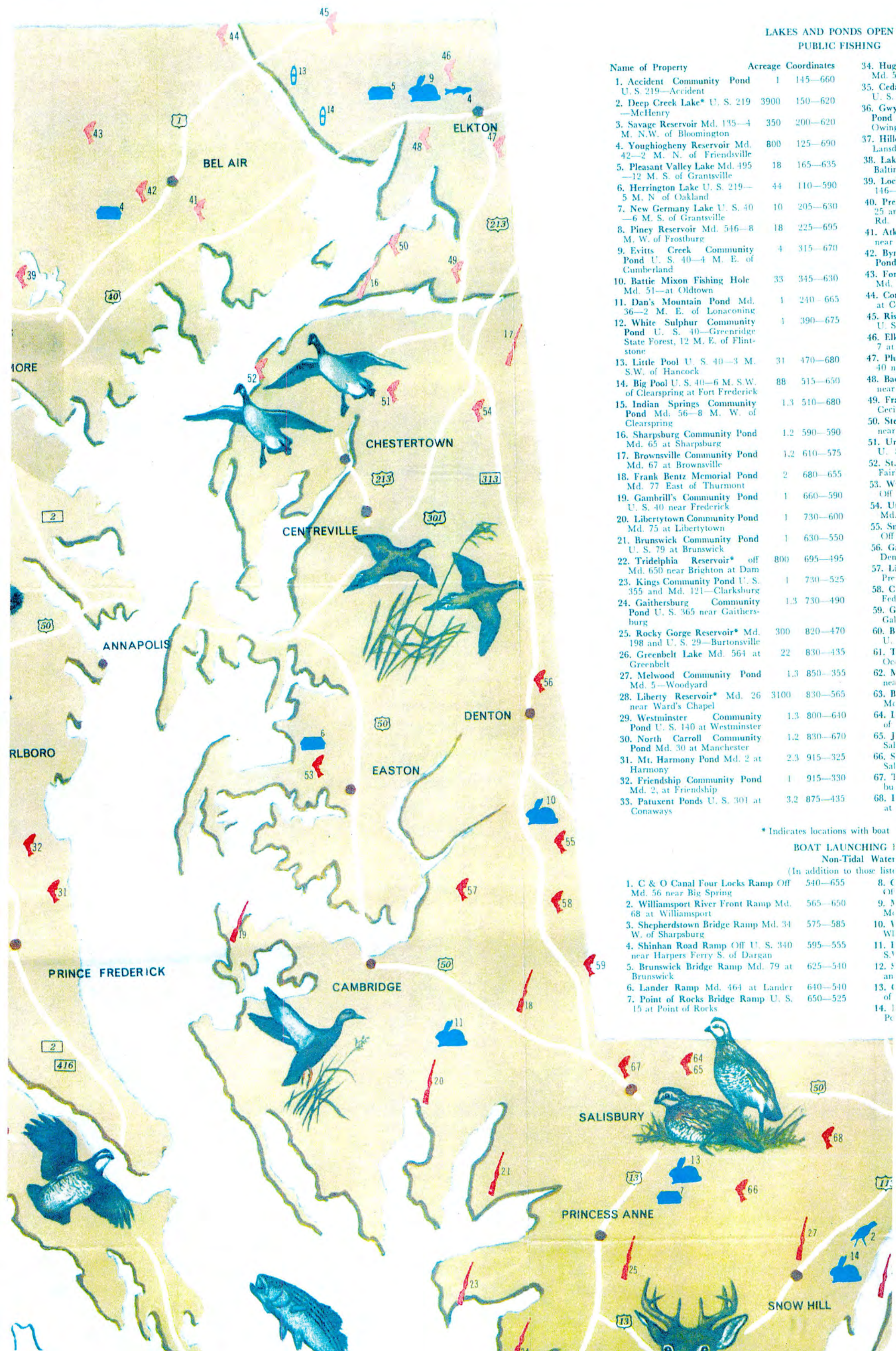

A MESSAGE FROM MARYLAND'S GOVERNOR
J. MILLARD TAWES



This is the 1965 edition of Maryland's Official Highway and Wildlife Resources Map. Our State has made significant strides both in highway construction and in providing outdoor recreational facilities, so that those who travel within our borders may be assured of both efficient transportation, and the opportunity to enjoy our natural resources. With the aid of these maps, the motoring public will be able to make the best possible use of the highway system

and become better acquainted with the outdoor recreational facilities administered by State agencies.

Featured on the wildlife map are the public hunting grounds, lakes and ponds, hatcheries, refuges, boat ramps and education areas maintained by the Department of Game and Inland Fish. I recommend also that you visit the fine picnic areas, forests and parks established by the Department of Forests and Parks.

Wherever you travel in our State, you will find accommodations staffed by people anxious to serve you and eager to help you enjoy Maryland.

Finally, I want to point out that Maryland's roadbuilders have incorporated every modern concept of safety into our highways. Won't you show an equal interest and drive with care, observing all the rules of the road established for your safety? I also urge all travelers to help us keep Maryland beautiful.

In the hope this map will be both interesting and helpful, I am with every good wish,

Sincerely yours,

J. Millard Tawes
Governor of Maryland

STATE ROADS COMMISSION

John B. Funk

Chairman of Commission and Director of Highways

Commission Members

Paul J. Bailey
Harley P. Brinsfield
Lansdale G. Clagett

Leslie H. Evans
John J. McMullen
William B. Owings

Official Highway Map
MARYLAND
with Wildlife Resources Map



PREPARED FOR FREE DISTRIBUTION BY THE MARYLAND STATE ROADS COMMISSION

1965

LAKES AND PONDS OPEN TO
PUBLIC FISHING

Range	Coordinates	Name	Location	Area	Notes
1	145-660	34. Hughesville Community Pond	Md. 5 at Hughesville	1	860-260
3900	150-620	35. Cedarville Community Lake	U. S. 301 at Cedarville	4	850-290
350	200-620	36. Gwynnbrook Community Pond	Off U. S. 140-near Owings Mills	1.3	865-580
800	125-690	37. Hillcrest Pond	Md. 144 at Lansdowne	4	900-510
18	165-635	38. Lake Roland*	Md. 139-Baltimore	80	910-560
44	110-590	39. Loch Raven Reservoir*	Md. 146-Dulaney Valley Rd.	2400	920-595
10	205-630	40. Prettyboy Reservoir*	off Md. 25 and U. S. 111 Beckleysville Rd.	1500	870-660
18	225-695	41. Atkisson Reservoir*	Md. 24-near Emmorton	91	980-605
4	315-670	42. Bynum Run Community Pond	Md. 22 at Bel Air	1.1	985-615
33	345-630	43. Forest Hill Community Pond	Md. 23 at Forest Hill	1.3	970-640
1	240-665	44. Conowingo Reservoir*	U. S. 1 at Conowingo	5000	1020-675
1	390-675	45. Rising Sun Community Pond	U. S. 1 at Rising Sun	1	1064-680
31	470-680	46. Elkton Community Pond	Md. 7 at Elkton	1.3	1135-648
88	515-650	47. Plum Creek Pond	off U. S. 40 near Elkton	4	1110-636
1.3	510-680	48. Back Creek Lake*	U. S. 213 near Chesapeake City	8	1128-615
1.2	590-590	49. Fraser Lake*	U. S. 213 near Cecilton	40	1117-590
1.2	610-575	50. Stemmers Lake*	Md. 282 near Crystal Beach	90	1090-590
2	680-655	51. Urvieville Community Lake*	U. S. 213 near Chestertown	35	1073-530
1	660-590	52. St. Paul's Lake	Md. 20 at Fairlee	30	1030-515
1	730-600	53. Wye Mills Community Lake*	Off U. S. 50 at Wye Mills	50	1060-405
1	630-550	54. Unicorn Lake*	U. S. 301, Md. 544 at Unicorn	45	1125-515
800	695-495	55. Smithville Community Lake*	Off Md. 404 at Smithville	40	1160-344
1	730-525	56. Garland Lake*	Md. 313 near Denton	45	1144-400
1.3	730-490	57. Linchester Lake*	Md. 331 at Preston	25	1112-322
300	820-470	58. Chambers Lake	Md. 306 at Federalsburg	6	1150-316
22	830-435	59. Galestown Lake	Md. 313 near Galestown	15	1167-270
1.3	850-355	60. Big Mills Lake*	Md. 12 off U. S. 113 near Stockton	10	1242-072
3100	830-565	61. Tingles Pond	U. S. 50 near Ocean City	3	1331-192
1.3	800-640	62. Moore's Pond	Off U. S. 13 near Pocomoke City	2	1218-096
1.2	830-670	63. Bishopville Community Lake	Md. 367 at Bishopville	8	1316-230
2.3	915-325	64. Leonards Lake	U. S. 13 north of Salisbury	30	1210-212
1	915-330	65. Johnsons Lake*	U. S. 13 at Salisbury	108	1204-203
3.2	875-435	66. Schumaker Lake	Md. 12 near Salisbury	35	1220-180
		67. Tony Tank	U. S. 50 at Salisbury	6	1202-198
		68. Powellville Pond*	Md. 354 at Powellville	4	1265-186

* Indicates locations with boat ramp facilities.

BOAT LAUNCHING RAMPS
Non-Tidal Waters

(In addition to those listed above)

Ramp Off	540-655	8. C & O Canal Viaduct Ramp No. 2	Off Md. 28 near Dickerson	570-505
Camp Md.	565-650	9. Monocacy River Ramp No. 1	Off Md. 28 near Dickerson	575-510
op Md. 34	575-585	10. Whites Ferry Ramp	Md. 107 at Whites Ferry	655-475
U. S. 340	595-555	11. Edwards Ferry Ramp	Off Md. 107 S.W. of Poolesville	665-465
argan Md. 79 at	625-540	12. Seneca Viaduct Ramp	Off Md. 112 and 190 near Seneca	715-445
at Lander	640-540	13. Octoraro Creek Ramp	Md. 222 S. of Conowingo	1010-665
mp U. S.	650-525	14. Port Deposit Ramp	Md. 222 near Port Deposit	1050-650



1	730-600	Md. 344 at Unicorn	40	1160-344
d	1	630-550		
F	800	695-495	45	1144-400
n	1	730-525	25	1112-322
s	1.3	730-490	6	1150-316
y	300	820-470	15	1167-270
r	22	830-435	10	1242-072
e	1.3	850-355	3	1331-192
t	3100	830-565	2	1218-096
y	1.3	800-640	8	1316-230
r	1.2	830-670	30	1210-212
y	2.3	915-325	108	1204-203
t	1	915-330	35	1220-180
t	3.2	875-435	6	1202-198
			4	1265-186

* Indicates locations with boat ramp facilities.

BOAT LAUNCHING RAMPS
Non-Tidal Waters
(In addition to those listed above)

mp Off	540-655	8. C & O Canal Viaduct Ramp No. 2	570-505
mp Md.	565-650	Off Md. 28 near Dickerson	
Md. 34	575-585	9. Monocacy River Ramp No. 1	575-510
S. 340	595-555	Off Md. 28 near Dickerson	
an	79 at	10. Whites Ferry Ramp Md. 107 at	655-475
79 at	625-540	Whites Ferry	
Lander	640-540	11. Edwards Ferry Ramp Off Md. 107	665-465
U. S.	650-525	S.W. of Poolesville	
		12. Seneca Viaduct Ramp Off Md. 112	715-445
		and 190 near Seneca	
		13. Octoraro Creek Ramp Md. 222 S.	1040-665
		of Conowingo	
		14. Port Deposit Ramp Md. 222 near	1050-650
		Port Deposit	



JOHN W. TAYLOR

Commission Members
Paul J. Bailey
Harley P. Brinsfield
Lansdale G. Clagett
Leslie H. Evans
John J. McMullen
William B. Owings

Official Highway Map

MARYLAND

with Wildlife Resources Map



PREPARED FOR FREE DISTRIBUTION BY THE MARYLAND STATE ROADS COMMISSION

1965

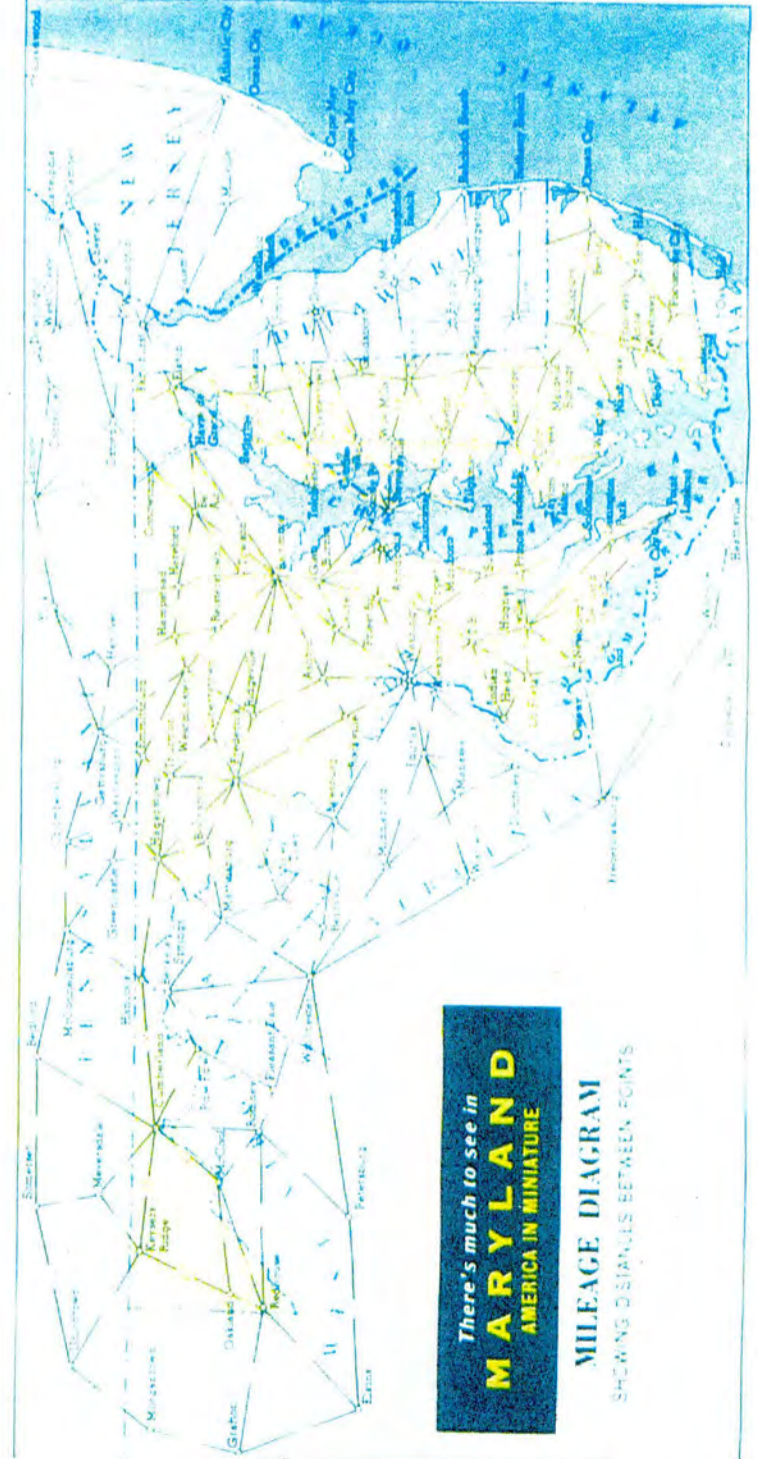

There's much to see in
MARYLAND
AMERICA IN MINIATURE

MILEAGE DIAGRAM
SHOWING DISTANCES BETWEEN POINTS

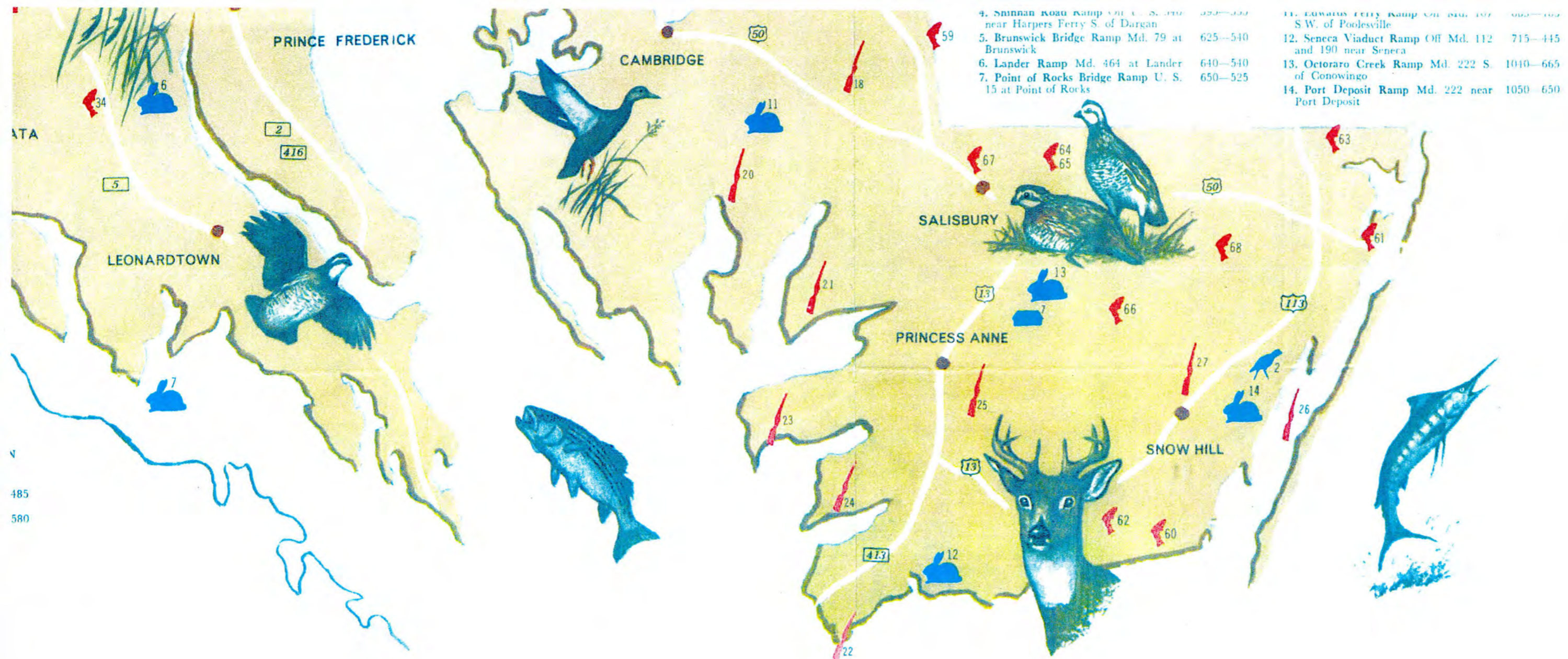

SMALLMOUTH BASS



BEAVER

JOHN W. TAYLOR