

# Standards and Guidelines for Architectural and Historical Investigations in Maryland



**MARYLAND HISTORICAL TRUST  
MARYLAND DEPARTMENT OF PLANNING**





# Standards and Guidelines for Architectural and Historical Investigations in Maryland

REVISED 2019  
Updated 2023

MARYLAND HISTORICAL TRUST  
MARYLAND DEPARTMENT OF PLANNING

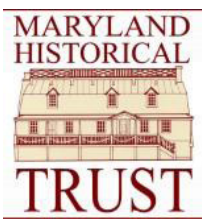

All rights reserved. Published 2019. Updated 2023.

Maryland Historical Trust  
Maryland Department of Planning  
100 Community Place  
Crownsville, Maryland 21032-2023

*Cover photographs:* The Beatty-Cramer House, Frederick County, photographed by David L. Ames, Center for Historic Architecture & Engineering, University of Delaware; Poplar Hill on His Lordship's Kindness, Prince George's County, photographed by William Graham; Mt. Lubentia Dairy, Prince George's County, photographed by William Graham.



# *Preface*

The Maryland Historical Trust was created in 1961 to assist the people of Maryland in identifying, evaluating, protecting and interpreting the state's significant historic, architectural, and cultural resources. The Trust's field survey program has operated continuously since that date, placing some 60,000 entries on the Maryland Inventory of Historic Properties. Over the years, documentation standards have evolved considerably. Early reconnaissance surveys produced brief architectural descriptions and minimal photographic coverage; subsequent efforts often expanded upon this basic information with historical research and measured drawings. Following the creation of the federal historic preservation program and the Trust's designation as the State Historic Preservation Office for Maryland, a more exhaustive inventory form was developed, based on the National Register format; this brought the state's field survey standards into close alignment with National Park Service requirements. Documentation produced in recent decades is rich in content, and has established the Maryland inventory's national reputation for thoroughness and professionalism. The architectural survey files, which comprise the Maryland Inventory of Historic Properties, are available at <https://apps.mht.maryland.gov/Medusa/>; this underscores the need to promulgate and maintain uniform documentation standards. To that end, the present publication has been developed. It contains comprehensive standards for conducting architectural investigations in Maryland, and provides guidelines for completing documentation for all types of survey projects. Originally published in 2000, this document was revised and updated in 2019 and is intended to serve as interim guidelines, as we develop an online submission process. We will release a new set of *Standards and Guidelines* in conjunction with the activation of the new process.



# *Table of Contents*

PREFACE.....	i
TABLE OF CONTENTS .....	ii
PERSONNEL.....	iv
COMMONLY USED ABBREVIATIONS.....	iv
I. INTRODUCTION.....	1
A Comprehensive Reference	
Survey Projects in Maryland	
Professional Qualifications	
Other Cultural Resource Investigations	
Additional Information	
II. ARCHITECTURAL INVESTIGATIONS IN MARYLAND.....	5
Introduction	
Survey Projects	
Compliance Investigations	
III. RESEARCH DESIGNS.....	11
Standards for Identification	
Mandatory Components	
Research Design Format	
IV. GUIDELINES FOR COMPLETING THE MARYLAND INVENTORY OF HISTORIC PROPERTIES FORM FOR ARCHITECTURAL AND HISTORICAL RESOURCES.....	17
Introduction	
Getting Started	
General Instructions for Completing Documentation	
Completing the Maryland Inventory of Historic Properties Form	
Accompanying Documentation	
V. GUIDELINES FOR COMPLETING NATIONAL REGISTER NOMINATION FORMS FOR MARYLAND PROPERTIES.....	39
Introduction	
Step One: Discuss your proposed nomination with MHT staff	
General Instructions for Completing National Register Documentation	
Completing the National Register Form	
Photographs	
Submittal of Documentation	
VI. FINAL SURVEY REPORTS .....	45
Final Report Contents	
Suggested Content Outline	
VII. COMPLIANCE REPORTS .....	49
Report Format and Content	
Coordinating with the SHPO	
Determining the Area of Potential Effect (APE)	

Identification of Properties	
Evaluation of Properties	
Assessing Effects	
Treatment	
VIII. ACCESSIONING PROCEDURES .....	59
Maryland Inventory of Historic Properties Form	
Compliance Reports	
Final Survey Reports	
HABS/HAER Materials	
IX. SURVEY AND PLANNING MATERIALS .....	63
Technical Information	
Survey Publications	
General Reference	
Selected Internet Resources	
APPENDIX A, Photo Continuation Sheet.....	67
APPENDIX B, Standards for Submission of Digital Images to the Maryland Inventory of Historic Properties .....	69
APPENDIX C, Submission Checklist.....	73
PHOTO CREDITS .....	75

# Personnel

## *Office of Research, Survey and Registration*

Marcia Miller, Chief	410-697-9573
Heather Barrett, Administrator of Architectural Research Allison Luthern, Architectural Survey Administrator	410-697-9536
Jessica French, National Register Administrator	410-697-9585
Grace Davenport, National Register Assistant	410-697-9623
Matthew McKnight, Chief Archaeologist	410-697-9562
Gregory Brown, Cultural Resource Information Manager Mary	410-697-9572
Kate Mansius, Architectural Registrar	410-697-9538
Lara Westwood, Librarian	410-697-9570
	410-697-9546

## *Office of Preservation Services*

Collin Ingraham, Chief	410-697-9558
Elizabeth Cole, Administrator, Project Review and Compliance	410-697-9541
Liz Casso, Preservation Officer	410-697-9533
Becky Roman, Preservation Officer	410-697-9587
Tim Tamburrino, Preservation Officer	410-697-9589

## *Office of Planning, Education and Outreach*

Nell Ziehl, Chief	410-697-9592
Ariane Hofstedt Administrator, Heritage Area Program	410-697-9586

*\*This list is current as of September 2023. Please refer to the MHT website for the most up-to-date listing. For e-mail addresses for individual staff members, please see <https://mht.maryland.gov/Pages/staff-directory-by-dept.aspx>*

# Commonly Used Abbreviations

Area of Potential Effect	APE
Advisory Council on Historic Preservation	ACHP
Certified Local Government	CLG
Cultural Resources Management	CRM
Code of Federal Regulations	CFR
Determination of Eligibility	DOE
Historic American Buildings Survey	HABS
Historic American Engineering Record	HAER
Historic Preservation Fund	HPF
Historic Structure Report	HSR
Maryland Historical Trust	MHT, Trust
Maryland Inventory of Historic Properties	MIHP
National Historic Preservation Act	NHPA
National Park Service	NPS
State Historic Preservation Office	SHPO

# MARYLAND BY JURISDICTION

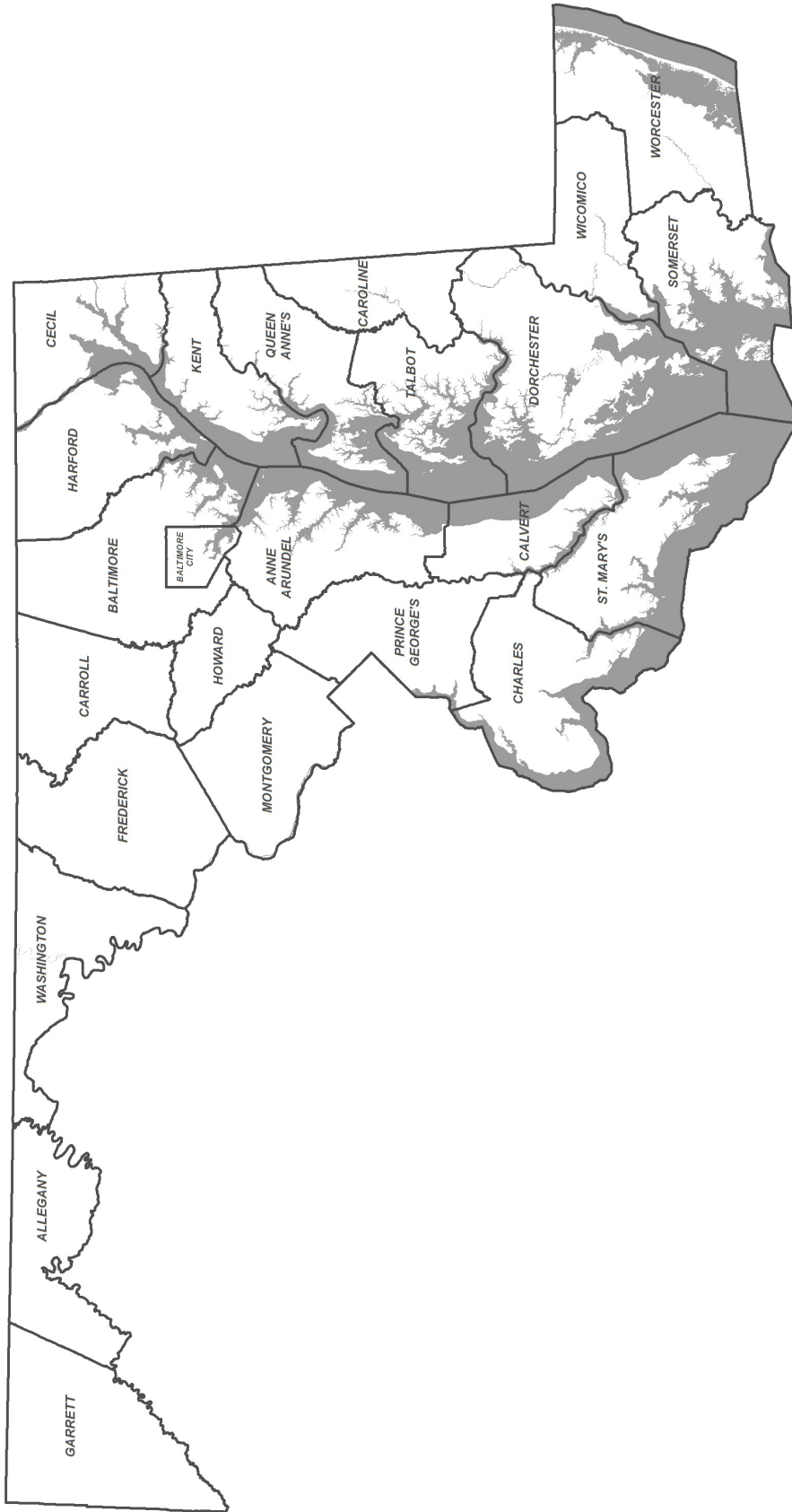



# I Introduction



## A Comprehensive Reference

**S**tandards and Guidelines for Architectural and Historical Investigations in Maryland is a comprehensive reference for professionals in their survey and research of architectural and historical properties in the state. Previously, researchers conducting architectural surveys or compliance projects in Maryland had to refer to materials published by a wide range of sources, including the National Park Service (NPS) and the Advisory Council on Historic Preservation (ACHP), as well as the Maryland Historical Trust (MHT). They reviewed a variety of publications, from the Secretary of the Interior's *Standards and Guidelines for Archeology and Historic Preservation* to the many technical, planning, and policy publications of the NPS and the Trust. The following is a compilation of information from these and other sources that will serve as a useful guide for identifying and documenting historic buildings, sites, structures, and objects in Maryland.

Members of preservation organizations and commissions; local, state, and federal government officials and administrators; preservation planners; developers; and others will find this a practical reference in cultural resource surveys and compliance reviews. The manual contains instructions in fieldwork and documentation that will help to develop professional standards and efficient procedures for recognizing and documenting historic properties. Its purpose is to foster a better understanding of the importance of high-quality research and to assist the Trust in speedier project review.

## Survey Projects in Maryland

As Maryland's State Historic Preservation Office (SHPO), the Trust is involved in the identification, evaluation, registration, preservation, and protection of historic properties. It derives its authority from State Finance and Procurement Article 5A, §§ 5A-325 and 5A-326 of the *Annotated Code of Maryland* and the *National Historic Preservation Act* of 1966 (NHPA), as amended in 1980.

To administer the federal historic preservation regulatory process detailed in the "Protection of Historic Properties" section of the U.S. Code of Federal Regulations, 36 CFR Part 800, Section 106 of the NHPA created the Advisory Council on Historic Preservation. The Council is an independent agency within the executive branch of the federal government. Its mandate is to inform, educate, encourage, and advise the President, Congress, and federal agencies on matters relating to historic preservation.

Under the authority and mechanisms established by Section 106, the Trust personnel, acting as the SHPO, review projects funded, licensed, or permitted by federal and state agencies for their compliance with existing laws related to historic preservation.<sup>1</sup> To further ensure the protection of historic properties, the SHPO is required to maintain an environmental review and compliance program. In short, the Trust assists federal and state agencies in determining the effects their actions will have on historic properties. This regulatory review process is often called a Section 106 review.

---

1. NHPA as amended in 1980; Section 106 (U.S.C. § 470f) and Section 110 (U.S.C. § 470h-2), as well as state preservation laws, (State Finance and Procurement Article 5A, §§ 5A-325 and 5A-326 of the *Annotated Code of Maryland*)



In accordance with the NHPA review process, the Trust is eligible for Historic Preservation Fund (HPF) grants for survey and documentation. Section 110 of the NHPA requires federal agencies to be responsible for documenting and preserving historic properties that they own or control. Section 110 also includes inventorying and nominating eligible historic properties to the National Register as well as ensuring that such properties are not “inadvertently transferred, sold, demolished, substantially altered, or allowed to deteriorate significantly.”

Assisted by HPF funds, the Trust maintains a statewide inventory of historic properties and other survey information. It also nominates significant resources to the Maryland Register of Historic Properties and the National Register of Historic Places. It works with federal agencies to determine the eligibility of properties under their jurisdiction or control. In addition, local governments often turn to the Trust for its cooperation and guidance in their development of local historic preservation programs. These include the Certified Local Government (CLG) program as well as many other eligible grant-funded activities requiring architectural investigations.

At the state level, Maryland law also requires a review of state-funded capital projects affecting historic properties. It spells out certain steps that state bodies or agencies must take before submitting a request for a capital project.<sup>2</sup> They are required to consult with the Trust “to determine if the proposed capital project or projects will adversely affect any property listed in, or eligible for, the Maryland Register of Historic Properties.” Like their federal counterparts, state agencies are responsible for identifying, documenting, and nominating all properties they own or control that appear to qualify for the Maryland Register

of Historic Properties. They must also ensure that any property listed or determined eligible for the Maryland Register is “not inadvertently transferred, sold, demolished, destroyed, substantially altered, or allowed to deteriorate significantly.” If a proposed capital project requires substantial alteration or demolition of a historic property, the agency must negotiate with the Trust to determine the appropriate mitigating measures, such as survey and other documentation.

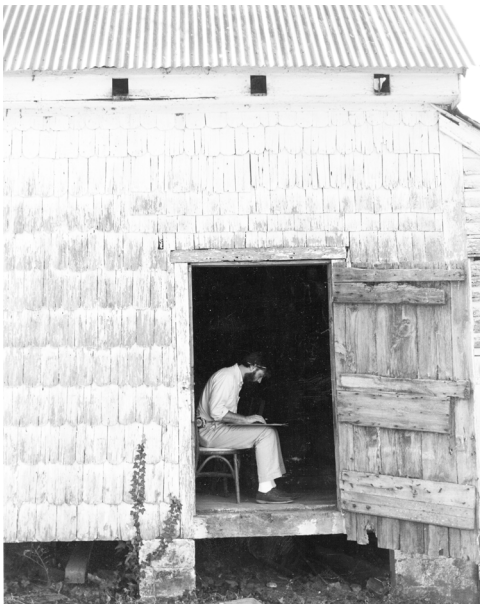

## Professional Qualifications

The requirements for personnel involved in architectural investigations conform to the national standards detailed in the Secretary of the Interior’s *Standards for Archeology and Historic Preservation* (Federal Register, 36 CFR Part 61). These professional qualifications, reprinted below, are used by the National Park Service to define the minimum education and experience necessary to perform identification, evaluation, registration, and treatment activities.

A professional’s expertise must be relevant to the preservation task at hand. For example, an architect would not be considered qualified to conduct a survey and perform documentation tasks unless he or she also met the standards required for a historian or architectural historian. Similarly, unless an architectural historian or historian also possesses a professional degree in architecture or is a state-licensed architect, he or she would not be qualified to conduct the stabilization, rehabilitation, or restoration of a historic property. Likewise, an archeologist would not be considered qualified to conduct an architectural survey unless he or she also met the standards for a historian or architectural historian.

Depending on a project’s complexity or the nature of the resources involved, the Trust may require multiple areas or levels of expertise. This requirement is usually fulfilled by

---

2. Art. 83B, §§ 5-617 and 5-618.



a team approach. In all cases, however, architectural investigators in Maryland will be required to meet at least one of the following professional qualification standards.

### *Architectural Historian*

The applicant, employee, consultant, or advisor will have a graduate degree in Architectural History or a closely related field of study, such as Art History; *plus* a minimum of two (2) years of full-time professional experience applying the theories, methods, and practices of architectural history to the identification, evaluation, registration, documentation, or treatment of historic properties in the United States and its territories; *and* products and activities that demonstrate the successful application of acquired proficiencies in the discipline to the practice of historic preservation; *or*

An undergraduate degree in Architectural History or a closely related field, such as Art History, *plus* a minimum of four (4) years of full-time professional experience applying the theories, methods, and practices of architectural history to the identification, evaluation, registration, documentation, or treatment of historic properties in the United States and its territories; *and* products and activities that demonstrate the successful application of acquired proficiencies in the discipline to the practice of historic preservation.

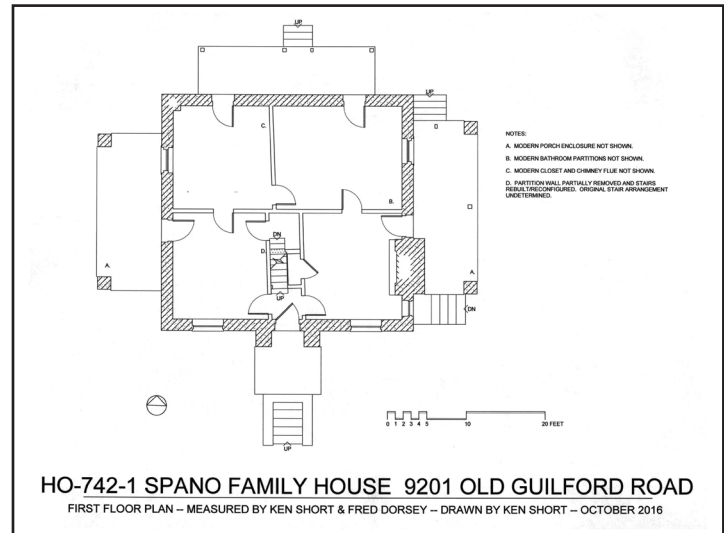

### *Historic Preservationist*

The applicant, employee, consultant, or advisor will have a graduate degree in Historic Preservation or a closely related field of study, such as Environmental Studies; *plus* a minimum of two (2) years of full-time professional experience applying the theories, methods, and practices of historic preservation to the identification, evaluation, registration, documentation, or treatment of historic properties in the United States and its territories; *and* products and activities that demonstrate the successful application of acquired proficiencies in the discipline to the practice of historic preservation; *or*

An undergraduate degree in Historic Preservation or a closely related field, such as Environmental Studies; *plus* a minimum of four (4) years of full-time professional experience applying the theories, methods, and practices of historic preservation to the identification, evaluation, registration, documentation, or treatment of historic properties in the United States and its territories; *and* products and activities that demonstrate the successful application of acquired proficiencies in the discipline to the practice of historic preservation.

### *Historian*

The applicant, employee, consultant, or advisor will have a graduate degree in American History or a closely related field of study, such as American Studies; *plus* a minimum of two (2) years of full-time professional experience applying the theories, methods, and practices of American history to the identification, evaluation, registration, documentation, or treatment of historic properties in the United States and its territories; *and* products and activities that demonstrate the successful application of acquired proficiencies in the discipline to the practice of historic preservation; *or*

An undergraduate degree in American History or a closely related field, such as American Studies; *plus* a minimum of four (4) years of full-time professional experience applying the theories, methods, and practices of American history to the identification, evaluation, registration, documentation, or treatment of historic properties in the United States and its territories; *and* products and activities that demonstrate the successful application of acquired proficiencies in the discipline to the practice of historic preservation.

## Other Cultural Resource Investigations

Cultural resource investigations in Maryland encompass a wide range of preservation initiatives beyond the scope and purpose of this document. Other major types of studies include the preservation components of comprehensive master plans, Cultural Resource Management plans, National Register nominations, and Historic Structure Reports. The focus of this document is the identification and documentation of historic cultural resources in Maryland that will initiate and support evaluation and registration program activities, such as the National Register of Historic Places.

The National Register of Historic Places is the official federal list of districts, sites, buildings, structures, and objects significant in American history, architecture, archeology, engineering, and culture. This national repository of information on historic properties that have been evaluated and documented according to uniform standards is a remarkable resource for preservation planning and the study of America's built environment.



All Maryland properties included in, or determined eligible for, the National Register are also given a parallel designation in the Maryland Register of Historic Properties. The Maryland Register, established by the Maryland legislature in 1985, provides eligibility for certain state regulatory protections as well as the availability of grant and loan programs. Inclusion in the Maryland Register requires that the resource be listed in or determined eligible by the Director of the Maryland Historical Trust for listing in the National Register of Historic Places. The National Park Service has published extensive technical information and specialized bulletins related to the survey and registration of historic properties.<sup>3</sup>

A Historic Structure Report (HSR), which records the documentary and physical research concerning a structure's evolution, is used in the management of historic resources. When used in conjunction with existing research, a HSR minimizes the loss of significant material or design elements when decisions are being made that affect a historic structure. As outlined in the National Park Service's *Cultural Resources Management Guideline* (NPS-28, October 1980), a HSR usually contains three major elements: administrative data, developmental history, and treatment and work recommendations. For additional information on what each of these sections includes see Preservation Brief 43: "The Preparation and Use of Historic Structure Reports." Normally, a HSR is prepared whenever a proposed major alteration of a historic site or structure will affect the qualities or characteristics that qualify the property for inclusion on the National Register.

## Additional Information

Chapter IX of this guide provides an extensive list of recommended readings applicable to architectural investigations in Maryland.

---

3. See *Bulletin 15: How To Apply the National Register Criteria for Evaluation*; *Bulletin 16A: How to Complete the National Register Form*; *Bulletin 16B: How to Complete the National Register Multiple Property Documentation Form*; and the *Maryland Supplement to Bulletin 16* (see Chapter IX for a complete list of NPS technical information publications).

# II *Architectural and Historical Investigations in Maryland*



## Introduction

Identifying and evaluating an area’s architectural and historical resources is basic to the preservation of its cultural heritage and distinctive built environmental character. Effective preservation planning depends on a survey of an area’s above-ground cultural resources, such as old and new buildings, street furniture, landscaping, open spaces, views, and vistas. This comprehensive description of an area’s physical characteristics helps to establish its historical character and to trace its development.

COUNTY	STANDING STRUCTURES BUILT PRIOR TO 1967	% OF PRE-1967 STANDING STRUCTURES SURVEYED	# OF STANDING STRUCTURES INCLUDED IN INVENTORY	#OF STANDING STRUCTURES LISTED ON NATIONAL REGISTER*	PUBLISHED COUNTY WIDE SURVEY?
Allegany	19,719	7%	1,420	3,270	No
Anne Arundel	56,004	5%	2,708	2,849	Yes
Baltimore City	185,557	3%	5,409	74,970	No
Baltimore	160,368	2%	3,455	6,292	No
Calvert	4,862	30%	1,454	54	No
Caroline	4,840	8%	402	671	No
Carroll	14,226	12%	1,750	2,421	No
Cecil	10,566	15%	1,611	547	Yes
Charles	7,343	17%	1,274	185	Yes
Dorchester	7,333	12%	869	1,350	Yes
Frederick	18,828	15%	2,773	4,379	No
Garrett	5,456	26%	1,417	413	No
Harford	18,788	12%	2,273	2,134	Yes
Howard	9,465	12%	1,171	452	No
Kent	4,293	17%	713	788	Yes
Montgomery	94,158	3%	2,743	1,876	Yes
Prince George’s	116,875	3%	2,937	5,483	Yes
Queen Anne’s	4,139	17%	724	485	No
St. Mary’s	7,623	14%	1,087	62	Yes
Somerset	4,069	14%	562	722	Yes
Talbot	5,910	20%	1,187	1,471	Yes
Washington	22,529	18%	4,039	4,987	No
Wicomico	13,260	5%	711	54	Yes
Worcester	6,242	10%	593	701	Yes

\* includes contributing resources within National Register Historic Districts

Preservation surveys define an area's distinctive character and identify the historic and cultural resources that meet the criteria for national, state, or local registers and merit whatever legal protection is available. Surveys also provide the groundwork for preservation plans.

Local designation created by city and county ordinances can go beyond the provisions and requirements stipulated by national and state registers. A local ordinance may prohibit demolition of recognized properties and may include design restrictions in a historic area.

## Survey Projects

Because architectural and historical investigations are critical in the preservation planning process and the rehabilitation of historic buildings, funding for specific survey projects is considered a good investment by both federal and state governments. Architectural and historical surveys in Maryland are supported by federal and state historic preservation funding. The Trust is the channel through which federal grant money is passed on to local governments and other entities through a subgrant program.

The 1980 amendments to the NHPA are the authority for transfers of funds to local governments and other entities. As amended, the NHPA established a Certified Local Government (CLG) Program that expanded the federal-state preservation partnership to include local governments, non-profit organizations, civic groups, and citizens. The state of Maryland ensures that at least ten percent of the congressionally appropriated Historic Preservation Fund is passed on to "Certified Local Governments" that qualify under the federal regulations.<sup>4</sup> The grant funding is available for a wide variety of projects, including but not limited to the development of preservation plans and architectural, archeological, or cultural surveys; educational outreach programs; National Register nominations; and training. Most often, CLG subgrants support some type of identification and evaluation of historic cultural resources.



The Trust also administers a state Historic Preservation Grant Fund established by the General Assembly in 1976 to encourage the preservation of historic properties. This grant fund supports both capital and non-capital Historic Preservation Grant Programs. Non-profit organizations, including State and Federal entities, and local jurisdictions are eligible to apply for non-capital grant funding.

Projects designed to locate and identify architectural and historical resources are among the broad array of survey and identification projects funded by Maryland Non-Capital Grants. Examples of these projects include county-wide surveys, collaborative regional heritage studies, and thematic surveys about a particular time period, property type, or topic. These comprehensive surveys provide a basis for evaluating a county's resources within their local historic context and aid in developing broader regional and thematic contexts. They also identify highly significant or endangered properties that should receive extensive documentation completed to *Historic American Buildings Survey* (HABS) standards including measured drawings, large-format photographs, and/or detailed building analyses by preservation professionals.

Evaluation and registration projects build on comprehensive surveys and determine if the subject properties meet specified criteria to be formally recognized in a register of historic properties. Such registration programs offer a number of benefits at community,

---

4. "Procedures for Approved State and Local Government Historic Preservation Programs," *Code of Federal Regulations*, 36 CFR Part 61.



county, state, and national levels. These can range from honorific recognition to financial incentives, including property and income tax deductions.

Listing in the National Register of Historic Places is the most common form of registration of historic properties in the state. Listing in the National Register follows a process established by the *Code of Federal Regulations*, 36 CFR Part 60. Properties listed in the National Register are listed concurrently in the Maryland Register. Under state and federal preservation laws, properties listed in the Maryland and National registers must be given due consideration in the planning of federal and state projects or actions and thus are given limited protection.

The evaluation and registration of historic properties in Maryland are part of the larger process of preservation planning; a process that organizes activities, such as identification, evaluation, registration, and treatment of historic properties, into a logical sequence. Surveys—the identification and evaluation steps—are the basic building blocks of this process. For the purposes of effective preservation planning, a survey must consider the historic context in which a particular property or resource exists.

A historic context is a format or method of organizing information about related historic properties into manageable units based on a theme, geographical limits, or chronological period. Establishing a historic context increases the reliability of decisions made concerning the identification, evaluation, registration, and treatment of historic properties. In many cases not all significant historic properties will have been identified at the beginning of the preservation planning process. Therefore, investigators should not only use all available existing data, but should also continually develop and broaden historic contexts to form a framework upon which preservation planning can build.

A historic context might encompass the development of an area, taking into account its history, architecture, archeology, engineering, and culture. It also might identify the significant patterns that individual properties represent within that context. One example is *Scientific Farming in Montgomery County between 1790 and 1860*. The study offers one theoretical construct of the effect of a particular movement or advance upon the history of agriculture. It establishes a time frame and geographical area from which discernible patterns in the county's historical and architectural development emerge. A set of such historic contexts can create a truly comprehensive view of an area's history, thus providing a broad definition that is useful to preservation planners and surveyors. As a result, researchers are able to anticipate, identify, and evaluate specific property types. The investigator should develop several levels of information that can be used in local, state, and regional planning. This ensures that the survey includes a range of properties representing all aspects of an area's history rather than a small, biased sample. One or more well-developed historic contexts for a geographical area can guide identification activities and assist in estimating the level of effort and methodology required by large-scale surveys.

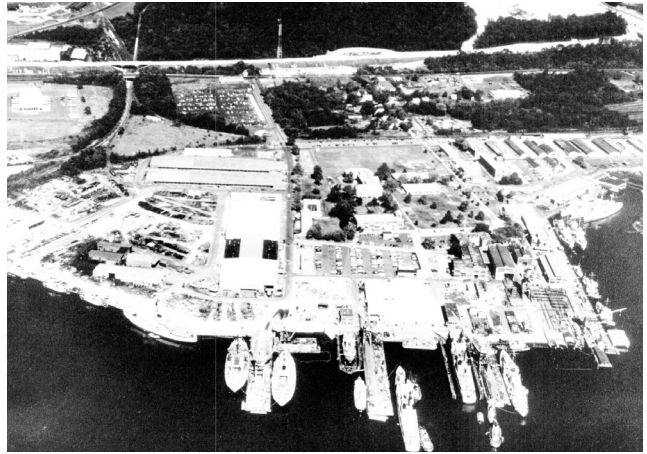

### *Comprehensive Survey Components*

All grant-funded comprehensive surveys include three major components: a research design, fieldwork and preparation of MHT inventory forms, and the final survey report.

The *research design* provides a framework that guides investigators in identification procedures. It includes an outline of the survey's objectives; a description of the research and fieldwork methods necessary to obtain data; and a discussion of expected results based on background research, experience, and a general knowledge of the survey area or

of areas with a similar environment or history (See Chapter III for detailed instructions and guidelines for preparation of the Research Design).

*Fieldwork* must be in keeping with the preservation goals or management needs that direct the survey, which should have as its overriding objective the greatest possible protection of the properties and historical context under study. Fieldwork techniques are usually related to the level of effort required by the significance of the resources. Architectural investigations are loosely organized into two levels: "reconnaissance" and "intensive" surveys.

The reconnaissance survey should document the kinds of properties identified; the boundaries of the area surveyed; the method of survey, including the extent of the survey coverage; the kinds of historic properties present in the surveyed area; specific properties that were identified; and the categories of information collected. It should also list places examined that did not contain historic properties.

The intensive survey should document the kinds of properties identified; the boundaries of the area surveyed; the method of survey, including an estimate of the extent of the survey coverage; a record of the precise location of all properties identified; and enough specific data on the appearance, significance, integrity, and boundaries of each property to permit an evaluation of its significance.

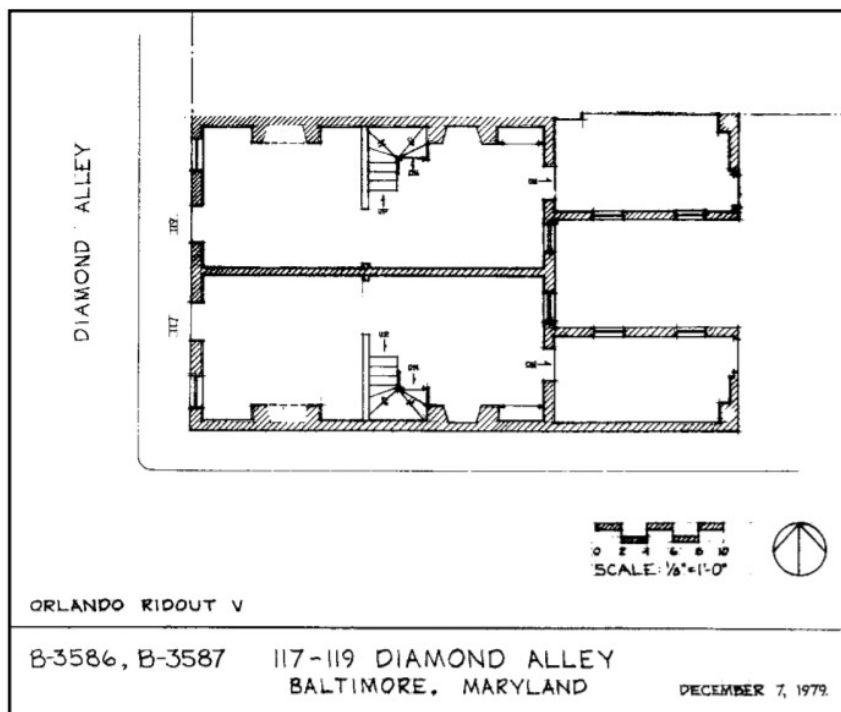

Architectural investigators may find it necessary to use both reconnaissance and intensive field survey techniques to accomplish the project goals. In developing their research design and methodology, investigators should use existing information as the basis for further research and ongoing fieldwork. As work progresses, they must continue to develop historic contexts as the underlying framework for identification and evaluation of the properties.

The assembled data is evaluated as the basis for determining eligibility for registration and for making treatment decisions. To ensure uniformity of information on properties surveyed in the state, the Trust has developed a standard inventory form, the *Maryland Inventory of Historic Properties (MIHP)* form. Data

recorded on a particular site includes an architectural description of the property, a statement that justifies its significance in relation to its context(s), analysis of the integrity of the property, and a record of when the property was surveyed and by whom. (See Chapter IV for instructions and guidelines for the preparation of these forms.)

Grant-funded surveys conclude with the submission of a *final survey report* that includes a statement of the survey's objectives, definition of the survey's geographical area, a discussion of the methodology and intensity of coverage, a description and the location of the results of survey, and recommendations for further work. (See Chapter VI for detailed instructions and guidelines for preparation of the Final Survey Report.)

## Compliance Investigations

An important goal of this guide is to facilitate the review of projects requiring compliance with federal and state historic preservation laws and regulations. Specific types of information are required by the governmental agencies responsible for identifying and treating historic properties, as well as by those who review activities affecting historic properties. On occasion, a project's cultural resources may also require archeological investigation, which is beyond the scope of this guide. For materials and sources of information on terrestrial and underwater archeology, preservation professionals should contact Trust staff. Standards and Guidelines for Archeological Investigations in Maryland are also available on the MHT website.



The Trust's Office of Preservation Services reviews projects for their effects on historic properties under the federal and state laws discussed in the previous chapter. As noted, the most common review is conducted pursuant to Section 106 of the *National Historic Preservation Act* of 1966, as amended, or State Finance and Procurement Article 5A, §§ 5A-325 and 5A-326, of the *Annotated Code of Maryland*. These laws require agencies to consider the effects of their undertakings on properties included in or eligible for the National Register of Historic Places and the Maryland Register of Historic Properties respectively. It is important to emphasize that any governmental agency initiating a project is responsible for compliance with the relevant historic preservation laws. The Trust's role is a consultative one in which it provides information, advice, recommendations, and determinations of register eligibility, as well as suggestions on how to avoid or minimize a project's adverse effects on historic properties.

The SHPO reviews more than 6,000 projects annually, on a first-come-first-served basis. Its response may take up to thirty days from the receipt of complete documentation from the requesting agency. Failure to submit the completed documentation, including the MIHP form and accompanying materials, could delay the process. Therefore, to provide adequate time to address all historic preservation concerns and to prevent avoidable delays, agency officials should consult the SHPO as early in the project planning process as possible—when alternative project locations, configurations, and methods are still available; or when program discussions begin.

Normally, coordination begins when an agency official or its designee submits a written request to the SHPO for assistance in identifying historic properties. A request should include:

- a description of the proposed project and the nature of federal or state agency involvement;
- a brief written justification of the APE with a clear delineation of the project's area of potential effect on an appropriate section of a labeled U.S. Geological Survey 7.5-minute quadrangle (or other 1 inch = 2000 feet scale map);
- a summary of the agency's review of existing information on known and potential historic properties that may be affected by the undertaking;
- a detailed description of current and past land use of the subject property; and,
- photographs.

Upon receipt of this information from the sponsoring governmental agency (or its applicant), Trust staff architectural historians will review the Maryland Inventory of Historic Properties for recorded standing structures. If archeological resources are involved, Trust archeologists will conduct a parallel review. Staff will also review other available records,





surveys, historic maps, and descriptions of present and past land use, among others, to determine if known or unidentified historic properties exist in the project's Area of Potential Effect. Based on this review, the SHPO staff will submit their recommendations to the inquiring agency, with comments on the possible need for further survey or other historic preservation activities.

Government agencies, professional historic preservation consultants, and others involved with compliance reviews are reminded that the Trust's insistence upon adherence to specific standards and guidelines stems, in part, from its legal responsibility to meet National Park Service requirements.

An aid to agencies responsible for managing large installations or land tracts or administering historic properties is the Cultural Resource Management Plan (CRMP), also referred to as a Historic Preservation Plan (HPP). Such plans provide an overview of the project area's historic contexts, describe inventoried historic properties and predicted resources, and recommend the appropriate treatment and management of the area's historic properties, both known and predicted. Generally, CRMPs are developed to address all historic property types on a particular site, including architectural and archeological resources.

To develop an effective plan, investigators should have a working knowledge and understanding not only of the area's historic properties, but also of the agency's mission, programs, and processes. Prior identification and evaluation greatly enhances a plan's usefulness in future compliance-related decisions. Also, the degree of prior investigation will influence the focus and research strategy for a given plan. For sites that encompass considerable acreage, for instance, agencies may find it more practical to complete phased investigations before developing their plans.

As with other cultural resource investigations, agencies should consult the Trust and the Federal Advisory Council on Historic Preservation, as appropriate, when deciding to develop a CRMP/HPP and determining the appropriate level of effort required. The content and form of a CRMP will vary depending upon the nature of the agency, project area, and historic properties involved. To determine the most appropriate methods and analysis, investigators should be clear on the precise objectives of a particular CRMP before initiating a study.



# III *Research Designs*



Working with the Architectural Survey Administrator of the Maryland Historical Trust, preservation planners and consultants for all grant-funded architectural investigations must prepare a research design incorporating the historic context framework established by the Trust. The design is a guide for efficient, goal-directed background research that occurs before field surveys are conducted. A chief component of the design is development of a localized historic contexts format, suitable in scale for the project area. An effective research design ensures that objectives are clear and that the products of the research and survey efforts are systematically collected and recorded and made available to those responsible for preservation planning.

## **Standards for Identification**

As used in the Secretary of the Interior’s *Standards and Guidelines for Archeology and Historic Preservation*, identification describes those activities undertaken to gather information about historic properties. When these activities relate to historic and architectural resources, they usually take the form of archival and background research, informant interviews, and surveys of standing structures.

The scope and nature of architectural investigations always depend on the existing knowledge of the survey or project area’s properties and the planning goals or current management needs. Identification activities generally have multiple objectives, reflecting complex goals and needs. As a result, combinations of these activities may be selected and assigned appropriate levels of effort to produce a flexible series of planning options.

The objectives, methodology, identification of the survey area, and expected results of a survey or compliance project are specified in the research design. These statements are required in all grant-funded architectural and historical investigations in Maryland before the fieldwork is performed but recommended for all intensive-level surveys regardless of the funding source. They must be reviewed and approved by the Architectural Survey Administrator. This requirement, as defined by the Secretary of the Interior’s *Standards and Guidelines*, “provides a vehicle for integrating the various activities performed during the identification process and for linking those activities directly to the goals and the historic context(s) for which the goals were defined.”

In practice, the research design also provides investigator(s) with the framework for developing a work program that defines planning goals for determining historic contexts and the scale and intensity of the survey work. It also specifies the proposed use of the survey data and can provide important interpretive information to generate local interest and participation in a survey project.

## Mandatory Components

As the vehicle for the integration of activities performed during the identification process, the well-crafted research design will, to the greatest extent possible, create linkages among the tasks in a survey project. These tasks include archival and background research, development of historic context(s), and fieldwork. Survey leaders will be responsible for ensuring the effective integration of all facets of the survey, which normally are conducted concurrently. The research design should include the following major sections:

### *Project Goals and Objectives*

This first section should include a statement of the survey or compliance investigation's goals and objectives. Ideally, the survey's goals should be based on historic contexts even though planning needs may determine the project's scope and priorities. Preservation planners should develop preliminary survey goals and objectives based upon current knowledge of a specific area's historic contexts or property types established through background research and assessments of previous research.

For example, suppose that future plans for highway improvements give high survey priority to a community within the highway's path. Background research reveals that the community was a tobacco port during the eighteenth century; experienced growth as an agricultural village in the nineteenth century after the construction of a turnpike; and developed into an ethnic suburban community in the twentieth century with the booming growth of regional urban centers and the construction of hard-surface roads.

Goals for a first stage survey effort might include determination of the boundaries of the eighteenth-century port; identification of any buildings still standing from the period; location of buildings requiring further study to determine whether they represent modernized eighteenth-century buildings; determination of likely archeological sites; identification of any surviving nineteenth-century agricultural or commercial properties; and identification of any ethnic neighborhoods or buildings that retain their architectural or cultural integrity.

The survey's objectives might be to characterize the range of properties in the region or planning area, to identify properties within a particular context, or to determine which properties in an area may be significant.

Survey planners should consult with SHPO staff when preparing a research design. Staff members in the Office of Research, Survey, and Registration and the Office of Preservation Services are experienced in designing and implementing surveys. They can provide valuable advice and models, as well as help ensure that the design is consistent with statewide survey standards and *Preserve Maryland II*, the statewide preservation plan for 2019-23.

### *Identification of the Survey Area*

Planners must clearly define the physical extent of the area to be investigated and the amount and kinds of information to be gathered from the properties. In planning a survey, they will need

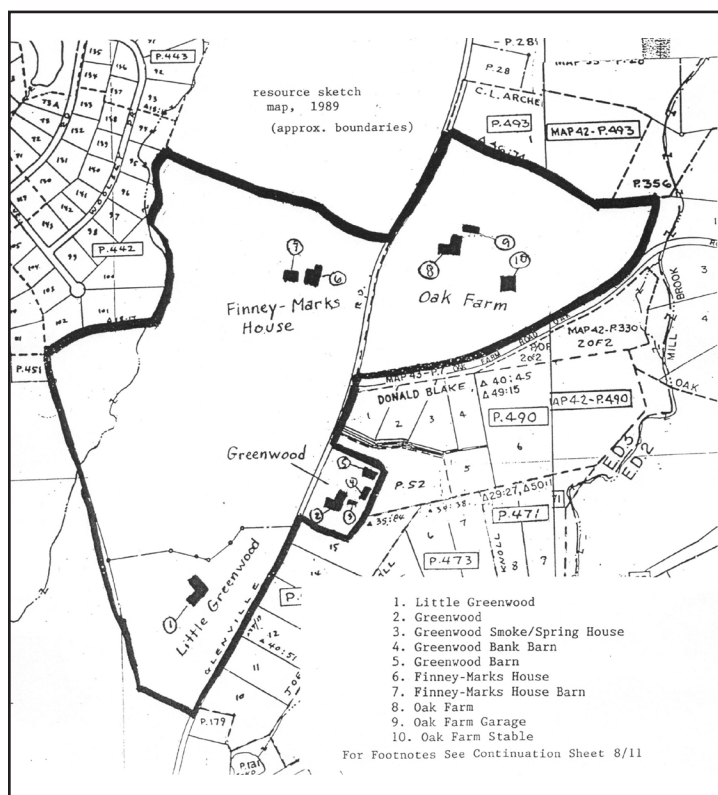

background data on the community or project area that provides an overview of its development.

This preliminary step and a reconnaissance survey of the community or project area will identify potentially significant areas or specific properties to target for possible intensive survey efforts. Usually jurisdictional or project-area boundaries define the survey area. In large project areas or in areas recognized for their development potential, however, survey efforts may be phased or targeted to address endangered properties or specific historic contexts.

If the background research suggests that significant properties may be concentrated in certain areas, the most cost-effective choice might be to survey those areas first. Areas where historic properties are less likely to be found would be given lower priority. Because historically significant places may not always be visually obvious, research designers should also make provisions for adding properties and areas identified through documentary research and subsequent field survey.

### *Discussion of Methodology*

The research design should include a detailed explanation of data collection methods and how those methods relate to the survey goals and objectives. The explanation should clearly define background and archival research and field-study methods so that others using the findings can understand how they were obtained and their possible limits or bias. Sources and methods of selecting field-survey techniques should be described and related to the preservation goals directing the survey effort. Planners should also establish approximate time frames within which the work, or particular phases of the work, should be completed. This statement should also include, or be supported by, a brief description of the historic contexts to be investigated.

### *Expected Results*

To the extent possible, those developing the research design should summarize their expectations as to the kind, number, location, character, and condition of historic properties from each historic context to be investigated.

### *Feedback for the Planning Process*

In conclusion, the research design should specify the purposes for which the survey data will be used. Typically, data is used to develop historic contexts or strategies for the preservation of historic resources; to revise community development planning; and to evaluate properties for designation locally or for the Maryland Register of Historic Properties and National Register of Historic Places. In the case of grant-funded survey contracts, resources identified through project research would be the basis of a preliminary plan for the evaluation and registration and/or a preliminary plan for protection and treatment.

## **Research Design Format**

All initial research designs for survey projects should be submitted to the Trust electronically for review in the following format: narrative sections should be typed, single-spaced, double-sided, and formatted for 8½" × 11" paper. For clarity, illustrations or maps may be larger than 8½" × 11", if they can be folded to fit in the report as pages or inserts in a pocket. The final research design will be a component of the Final Survey Report. It should reflect the project's adjusted goals and priorities, which usually are revised as the survey matures and new historic contexts are developed and others are refined. (See Chapter VI and VII for a description of research designs for the Final Survey Report or compliance document.)

## *Suggested Research Design Outline*

### **Title Page**

- Include the name, nature, and location (with county) of the project.
- Clearly designate the report's author(s) with complete email and mailing addresses.
- Clearly designate the project's principal investigator(s) with complete email and mailing addresses.
- List names and complete mailing addresses of the lead government agency or non-profit organization and of the government agent (e.g., engineering firm, developer, or project sponsor, if applicable).
- Indicate the date.

### **Introduction**

- Begin with a brief statement of the nature of the project, the source of funding, and sponsors.
- Include locator maps.

### **Goals and Objectives**

- Include a detailed statement of goals and objectives.
- Explain the applicability of the work to broader county or regional historic and architectural contexts.

### **Identification of the Survey Area**

- Clearly define the physical extent of the area to be investigated, including acreage.
- Describe the amount and kinds of information to be gathered about the properties in the area.

### **Methodology**

- Explain the research methods to be used to develop the historic context(s).
- Describe the field survey techniques available and the levels of effort that may be assigned.

### **Historic Overview of the Project Area**

- Identify the concept, time period, and geographical limits for the historic context(s).
- Collect and compile existing information about the historic context(s) in a written narrative.
- Include maps depicting potential locations of resources along with boundaries of the area to be surveyed.

### **Description of Expected Results of Field Investigations**

- Describe field conditions and constraints.
- Describe potential architectural and historic resources with reference to comparable published studies, if known. Maryland Inventory site numbers issued by the Trust's Office of Research, Survey, and Registration must be utilized in the text and illustrations of the final report.
- When possible and appropriate, include interpretations referring to historic contexts; research questions; and integrity/significance (i.e., eligibility for the National Register).

### **A Plan for Evaluating and Registering Resources**

- State the minimum information necessary to evaluate properties against Maryland Register and National Register criteria.
- Explain how historic significance and historic integrity will be assessed and related to the properties surveyed.

### **Preliminary Plan for Protection and Treatment**

- Summarize and evaluate the proposed methods and techniques to be used for protection and treatment.
- Assess the need for additional investigations or resource treatment.
- Discuss the study's public interpretation measures, if applicable.

### **Review of Bibliographic and Documentary Material**

- The style of all citations should follow the latest edition of *The Chicago Manual of Style*.





# IV *Guidelines for Completing the Maryland Inventory of Historic Properties Form for Architectural and Historical Resources*



## Introduction

The Maryland Inventory of Historic Properties is a broadly-based record of Maryland's historical and cultural heritage. It currently consists of information on more than 60,000 properties, including districts, sites, buildings, structures, and objects of known or potential value to the prehistory, history, upland and underwater archeology, architecture, engineering, and culture of the state.

Established primarily for information and record purposes, the inventory is an important repository of useful data for the study of Maryland's history and culture. These records provide information on a wide range of historic properties and are used by scholars and planners to identify the state's heritage, evaluate that heritage, and plan for its preservation. The MIHP is a research and documentation – not a regulatory – instrument. The legislature provided elsewhere in State law for mechanisms—separate from the MIHP—giving both the State and local jurisdictions the authority to regulate appropriately designated historic resources. Inclusion in the inventory also serves as a red flag, alerting preservationists, governmental agencies, organizations, and others that a property may have some level of historical significance and may require further study and evaluation.

Whereas inclusion in the inventory is tacit recognition by the state that a property contributes to the historical and cultural heritage of Maryland, protective and financial benefits, often associated with historic properties, are not automatically extended to inventory properties. Nor are inventory properties automatically evaluated with regard to significance or eligibility for inclusion in the National Register of Historic Places. Inventory documentation does, however, provide the basis upon which evaluation decisions can be made.

The Maryland Inventory of Historic Properties, created by an act of the Maryland Legislature, is maintained by the Maryland Historical Trust, an agency of the Maryland Department of Planning.<sup>5</sup> The inventory is divided into two parts: standing structures (i.e., buildings, structures, objects, and districts) and archeological sites. Properties that are included in the inventory are usually at least fifty years of age and should be of potential significance in relation to major historical trends at the local or state level.

A property should also demonstrate the potential for historical significance in one or more of four aspects of Maryland history:

- association with historic events or activities;
- association with persons who are important to the community or to specific developments of history;

5. *Annotated Code of Maryland*, Article 83B, Title 5, Subtitle 6, Section 5-615.

- embodiment of distinctive characteristics of a type, period, method of construction, or the work of a master; and
- potential to provide important information about history or prehistory.

The Maryland Historical Trust also maintains the Maryland Register of Historic Properties and administers the state's nominations to the National Register of Historic Places. The National Register includes a broad range of types and levels of significance of properties, but it reflects a more intensive level of documentation and evaluation not generally associated with the Maryland Inventory of Historic Properties. To be entered in the National Register, the property must go through a more rigorous nomination process than required for inclusion in the inventory. All properties listed on the National Register, if they have not been previously recognized, are automatically included in the Maryland Inventory. For information and questions on the National Register, please refer to Chapter V and contact the Administrator of Evaluation and Registration, Maryland Historical Trust, at 410-697-9562.

## Getting Started

The following guidelines describe the requirements for completing the form used to add standing structures to the Maryland Inventory of Historic Properties. These guidelines should also serve as a standard for more intensive survey projects. Survey work that uses state or federal funds or is required by the compliance process is directly supervised by the Trust and may incorporate more specific requirements. For further information, consult the scopes of work or Memoranda of Agreement applicable to the specific project.

The archaeological section of the Maryland Inventory uses an entirely different form. For information on the archaeological inventory forms and inventory number assignment, please contact the Archaeological Registrar. Copies of the *Standards and Guidelines for Archeological Investigations in Maryland* are available on the MHT website.

The Maryland Inventory form and accompanying documentation must be prepared by a professional qualified in at least one of the following disciplines: architectural history, American history, historic preservation, or a closely related field. Please note that archeology is not considered a closely related field for inventory documentation of standing structures. The federal qualifications for "Procedures for Approved State and Local Government

Historic Preservation Programs," in the *Code of Federal Regulations*, 36 CFR Part 61 are more fully described in Chapter I, Section C of this manual. In certain cases, if the sole purpose is to add a historic property that is of interest to an individual or organization, the owner or a member of the organization, with prior approval of the Trust, may complete the inventory form. All documentation must meet the standards and adhere to the guidelines outlined in this chapter.

The Maryland Historical Trust's goal is to obtain detailed, comprehensive documentation and research on all properties. For practical purposes, survey documentation may be broken down into two levels of information: reconnaissance (the minimal amount) and intensive (in-depth research and analysis). Recognizing that surveys are made for diverse reasons, the Trust will accept reconnaissance

level documentation when appropriate to the nature of the resource and/or the project. The surveyor must always consult with Trust staff for prior approval before undertaking a reconnaissance survey.

Reconnaissance documentation provides information sufficient to identify and locate properties and may serve as a useful planning tool. A reconnaissance level survey will in-

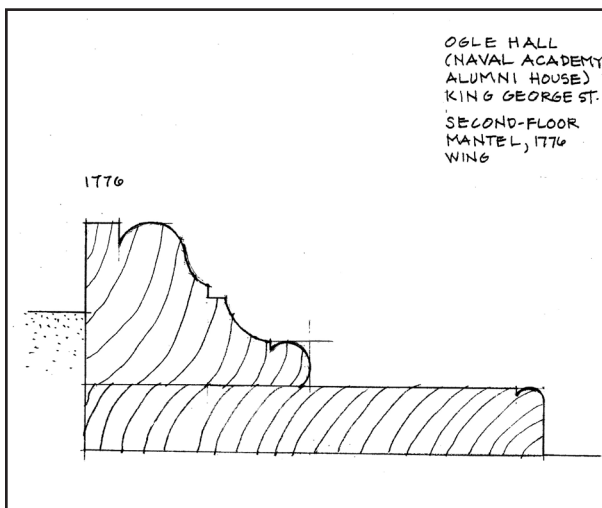



clude a concise overall description of the resource as well as general basic research of the site. At this level, the surveyor may document the exterior of the building only.

Intensive level of survey is required to determine eligibility for inclusion on the National Register of Historic Places, as well as the Maryland Inventory of Historic Properties. Trust-supervised survey projects, including grant-funded and review and compliance projects, are also required to submit intensive level documentation. An intensive-level survey must include a comprehensive description of the exterior and interior of the building and emphasize the key elements that determine the resource's significance. All intensive level survey documentation must include an analysis of the resource and site-specific research into its history. A discussion of the history will place the property in its context by addressing its relationship to the history of the community and/or the state and other similar properties. Documentation would include multiple photographs illustrating various aspects of the property.

Regardless of the level of survey, the preparer must complete all sections of the MIHP form and a capsule summary. For MHT grant-funded survey and National Register nomination projects, the documentation will also include: at least one 5" x 7" black and white or color photograph; a map locating the property on the USGS topographic quadrangle; and, a parcel map showing the exact boundary of the surveyed area. Please refer to the Accompanying Documentation section for a more comprehensive discussion on specific requirements. Digital files of all submitted materials must be included on an archival disk with the final submittal.

## General Instructions for Completing Documentation

The *Maryland Inventory of Historic Properties (MIHP) Form* is the only form used for all architectural fieldwork in Maryland, regardless of the level or type of survey. The MIHP form is available electronically as a Microsoft Word file located on the MHT website. The form may also be sent via e-mail upon request by MHT staff. The form is supplemented by continuation sheets, which are also available electronically as a Microsoft Word file located on the MHT website. In most cases, an Addendum form should be used when updating an existing MIHP form (see page 33 for more details).

The four-page MIHP form should be completed using a computer. When submitted to MHT, the hard copy of the MIHP form and all accompanying documentation must be printed on acid-free, plain white bond paper. The information must be submitted electronically as well (a Microsoft Word file is preferred). Consistency in completing the form is critical. Standardized terminology and approaches as well as general definitions are included throughout these instructions. Complete each section and fill in every blank. Use "unknown" or "N/A" when necessary. Continuation sheets, with the appropriate heading, may be used for any section where space is limited, but only after the space has been used; do not type in "see continuation sheet." Enter the property name, inventory number, and section and page numbers in the header of each continuation sheet.

For projects designed to determine National Register eligibility, the property must be placed in its historical context, and the statement of significance must address applicable National Register evaluation criteria. If, in the opinion of the preparer, the property is ineligible, the statement must address all criteria for evaluation and discuss how the property fails to meet each one. The actual determination of eligibility should be placed on an ac-

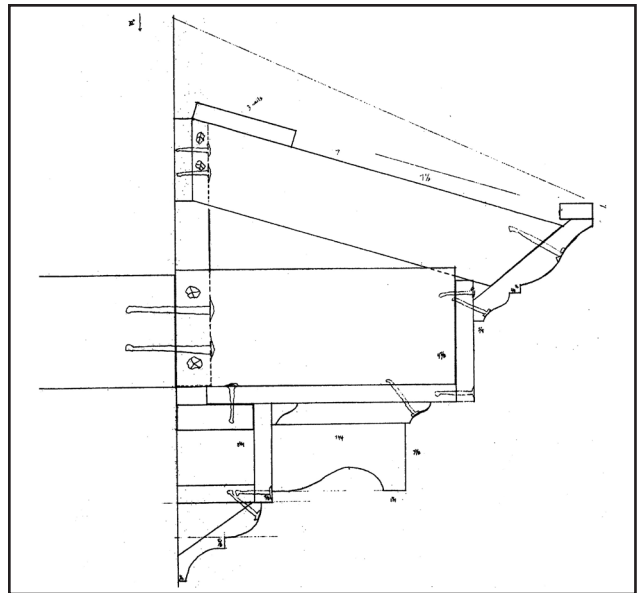

companying Determination of Eligibility (DOE) form and the box under Evaluation should be checked “Yes” to indicate a determination has been made. In the preparation of any DOE form, the preparer should consult the Guidelines for Compliance-Generated Determinations of Eligibility (DOEs) found at: <https://mht.maryland.gov/projectreview/project-review-DOE-Guide.aspx>

## Completing the Maryland Inventory of Historic Properties Form

Each section of the Maryland Inventory form should be completed according to the instructions listed below. Do not leave any section blank. The instructions are organized according to the number and name of each section of the form. Specific directions, terminology, and definitions are included.

### *The Inventory Number*

An inventory number must be included in the appropriate space at the top right-hand corner of each page of the form and on all continuation sheets, maps, drawings, photographs, and the capsule summary. The inventory number should be entered exactly as issued by MHT. The inventory number formatting should not be altered and no substitutions in punctuation should be made. Leading zeros should not be incorporated into an inventory number, unless specifically issued by MHT. If there is any question of the proper inventory number, please contact the Inventory Registrar directly. The preparer must confirm that the site does not hold an existing inventory number before requesting a new number; this information can be verified by consulting Medusa, Maryland’s Cultural Resource Information System. It is the preparer’s responsibility to identify previous documentation of the site. Inventory numbers should be added to all documentation before submitting any forms or draft reports for review and compliance surveys, as well as grant-funded projects.

Please note that if an MIHP (or DOE) form is being prepared for an individual resource located within the boundaries of an existing district, then a new, separate inventory number must be requested and assigned to that particular resource. Please do NOT use the inventory number assigned to the district when preparing forms and accompanying documentation for an individual resource located within the district. Likewise, if a number has been previously assigned to an individual resource or property, do not use that number when documenting a larger group of resources. Inventory numbers are not transferrable to other properties once assigned by MHT.

Inventory numbers are assigned only in coordination with the Inventory Registrar. Local jurisdictions cannot assign numbers. If an inventory number has not already been assigned, please contact the Inventory Registrar. The formal request should be emailed to the Inventory Registrar and should include the historic names and complete addresses (including zip codes) of all properties with each site clearly located on a late 20th century United States Geological Survey (USGS) topographic quadrangle map at 1:24,000-scale, along with a zoomed-in view of the map with the exact boundary of the surveyed area clearly marked. The late 20th century USGS topographic quadrangle map is preferred over the modern version. All map files should be submitted



as PDFs; please do not embed images in a Word document. A set of maps should be prepared for each number requested; do not include multiple properties on a single map. If requesting a number for a complex or district, please provide an inclusive list of all street addresses. If the resource does not have a singular street address, it may be necessary to provide a rough verbal boundary description instead.

Inventory numbers should only be requested in conjunction with the preparation of an MIHP, DOE, or NR form. Be prepared to notify the Inventory Registrar as to which form of documentation you are preparing, and if the documentation is being prepared for compliance purposes. Inventory numbers will not be assigned for any other purpose. All inventory numbers are issued by MHT with the expectation that the completed documentation will be prepared in accordance with the Standards and Guidelines, and that MHT will receive a complete copy for inclusion in the library as the official repository of the Maryland Inventory of Historic Properties. If an inventory number is requested in error and is later found to be no longer necessary, please contact the Inventory Registrar.

If a DOE “short” form for certain ineligible properties is being prepared, do not request an inventory number from the Inventory Registrar. Properties being documented on DOE “short” forms are not added to the MIHP and their survey should be coordinated with the appropriate Project Reviewer in the Office of Preservation Services. The Inventory Registrar will not assign an inventory number to a property being documented on a DOE “short” form.



### *Section 1: Name of Property*

This section identifies the various names by which the property has been known. The term “property” refers to the entire historic resource being documented. A property may be an individual building, site, structure, or object, or it may be a district consisting of numerous buildings, sites, structures, or objects. For Maryland Inventory purposes, MHT prefers to use the term ‘survey district’ when referring to areas that are not National Register-listed historic districts and have not been formally determined eligible.

**Historic Name:** The historic name is generally the name associated with the historic significance of the property. The historic name of the property will be used to identify the property in the Maryland Inventory of Historic Properties and any publications. The name as entered on the MIHP form should correspond with the name as it has been entered into Medusa. If the historic name changes during the course of research, it is the preparer’s responsibility to alert the Inventory Registrar of that change. The historic name is preferred for general reference because it continues to be meaningful regardless of changes in ownership or use.

**Other Name:** In the space provided, enter any other names by which the property has been commonly known, in chronological order of their use. These may reflect its history, current ownership, or popular use, and may or may not fall into the category of historic name. In some circumstances, there is reason to use a common name for the property rather than the historic name. In this situation, enter “preferred” after the appropriate name and explain the reason in Section 8: Significance. Be consistent throughout the form—use the historic or preferred name for all labels, including maps, drawings, and photographs.

If the property being documented is part of a historic district or thematic or multiple-property study for which a separate inventory form has been prepared, include the



name of the district or study in parenthesis to the right of the historic or preferred name, and refer to the name and inventory number of the district or study in the narrative.

### *Section 2: Location*

**Street and Number:** For individual buildings, structures, sites, and objects, enter the number and name of the street or road where the property is located using the actual premises address. If the road has a route number rather than a name, give the number and indicate whether it is a federal, state, or county road. If a property does not have a specific address, give the names of the nearest roads and the property's relationship to the roads (i.e., ½ mile east of Middletown Road; or northwest corner of Hampton Road and Smith Avenue). The address must be as exact as possible to be entered into the Trust's searchable database. For districts, enter either the inclusive street address numbers for all primary buildings and structures (i.e., 12-157 South Street, 414 Eutaw Street, and 40-819 Maple Avenue); or a rough description of the boundaries (i.e., roughly bounded by Perdue, South, Roland, and Belmont streets; or eight blocks in downtown Gouldville). If the location is not to be published for any reason, place an "x" in the space allotted.

**City, Town:** Enter the name of the city or town where the property is located, followed by the zip code. If the property is not located within the boundaries of a local jurisdiction, then place an "x" in the space for vicinity.

**County:** Enter the county in which the property is located.

### *Section 3: Owner of the Property*

Give the names and addresses of all owners of the property at the time the inventory form is completed. Use the Maryland Department of Assessments & Taxation (SDAT) as the source for this information. For ten or fewer owners, list each one; use a continuation sheet if necessary. For more than ten owners, enter "multiple ownership" in the space provided, and give the name of a contact person, if appropriate.



### *Section 4: Location of Legal Description*

Usually, the legal description of a property is in the land records office in the courthouse for the county or city in which the property is located. You may also find the information online at the SDAT. Cite the tax map, parcel designation, and deed reference to Liber (deed book) and folio (page); these are usually included in the assessment records. For more than ten owners, enter "multiple deeds" in the space provided, with the name of a single contact person, if appropriate.

### *Section 5: Primary Location of Additional Data*

Mark "x" in the appropriate spaces that apply to the property. Check, or list, any prior historical or architectural studies in which this property was included. Indicate whether the property has been listed on, or has been determined eligible for, the National Register of Historic Places or the Maryland Register of Historic Properties. Preliminary research should include the completed DOE forms for individual properties determined eligible for the National Register through review and compliance projects. Also determine whether a Historic Structure Report or other field report has been completed. List under Other any broad surveys that include the property. Site-specific research should be listed in Section 9: Major Bibliographic References.

## Section 6: Classification

Mark “x” in the appropriate spaces that apply to the property.

**Category:** Mark the one most appropriate resource type on the list. If the property has a number of resources, choose the most important or main resource. Definitions of each resource type are listed below.

- **District:** A district possesses a significant concentration, linkage, or continuity of sites, buildings, structures, or objects united historically or aesthetically by plan or physical development. Examples include residential areas, industrial complexes, rural villages, transportation networks, and large landscaped parks.
- **Building(s):** A building, such as a house, church, hotel, or similar construction, serves principally to shelter any form of human activity. The term building may also be used to refer to a historically and functionally related unit, such as a courthouse and jail or a house and barn.
- **Structure:** The term structure is used to distinguish from buildings those functional constructions usually made for uses other than human shelter. Examples include bridges, corncribs, kilns, historic vessels, and roadways.
- **Site:** A site is the location of a significant event, a prehistoric or historic occupation or activity, or a building or structure, whether standing, ruined, or vanished, where the location itself possesses historic, cultural, or archeological value regardless of the value of any existing structure. Examples include gardens, ruins, shipwrecks, designed landscapes, and land areas having cultural significance.
- **Object:** The term object is used to distinguish from buildings and structures those constructions that are primarily artistic in nature or are relatively small in scale and are simply constructed. Although it may be movable by nature or design, an object, as referred to here, is associated with a specific setting or environment. Examples include monuments, boundary markers, and sculptures.

**Ownership:** Mark whether the property is currently public or private property.

**Current Function:** Mark the current use of the resource(s). Describe its historic function or use in the narrative portion of Section 8: Significance.

**Resource Count:** Count both the contributing and non-contributing resources that make up the property, and place the numbers by each resource type (i.e., buildings, sites, structures, objects) in the appropriate column. Total each column. Include in this count all resources, regardless of whether they already appear in the Maryland Inventory or are listed in the National Register. Completing this item requires three steps: 1) classify each resource by category: building, site, structure, or object; 2) determine whether each resource does or does not contribute to the potential historic significance of the property; 3) count the contributing and noncontributing resources in each category. For additional information regarding contributing and non-contributing resources, see below in Section 7.

Proper headings on continuation sheets include name of property as it appears after “historic name” on page one of form and section and page numbers.

Record the number of resources previously entered in the Maryland Inventory or listed on the National Register in the space provided. This number should also be included in the total resource count.

## Section 7: Description

**Condition:** Identify with an “x” the condition of the property as it existed at the time of the survey.

**Narrative Description:** Provide a narrative describing the property and its physical characteristics as it exists today, noting the features which create the historic character

plus changes that have been made over time and the impact of those changes on the historic character. The narrative should be concise but thorough, factual, and well organized.

Where brevity is required, emphasize the main elements that determine a particular property's character—form, plan, spatial use, and key features. The narrative should provide a detailed, comprehensive description of the property, whether buildings and structures or districts and sites. It should cover the historic and non-historic features that characterize the property. The text should trace the property's evolution and describe its present-day physical characteristics. If the property is a primary building or structure, the narrative should include a detailed description of its exterior. Also, because information on the interiors of resources is essential in evaluating their significance, ideally, an inventory listing should cover the interiors of historic properties.

## Outline for Describing Properties in Section #7

### Introduction

Briefly describe the geographic location of the historic site or property.

- Summarize the physical setting and the number and type of buildings or features. Include all structures, even if they are not considered to be significant and are not mentioned again in the form. Include approximate construction dates to the extent possible. A discussion of specific dating evidence should be included in the appropriate sections of the detailed description.

### Detailed Description

Begin with the principal dwelling house (or the dominant structure, if not a dwelling site).

- Describe the overall form, size, height, and number of bays, roof form, and principal materials.
  - ▶ If the building was constructed in more than one stage, briefly summarize the building sequence in a logical order, even including modern additions that may not be discussed any further. If for some reason this cannot be done, be careful that your description doesn't become confused with references to the different stages. Sometimes a series of simple sketch plans labeled "Period I, Period II," etc., with the text keyed to the drawing will prove to be the easiest solution.
- Proceed to a more detailed description of each exterior façade. Begin with the front or principal entrance façade, and then move in a logical sequence (clockwise; counter clockwise; front, rear, left gable, right gable). If there is a wing or addition, it is often helpful to describe the façade affected by the wing last, so that the description of the wing can follow in a logical sequence. Where relevant, the description should note when a feature is not original or historical.

► The description of the façade should follow a logical order that is repeated for each successive façade. For example:

Fenestration: first story, second story, roof (if dormers), cellar openings.

Materials: foundation, siding or brick bonding, roofing.

Decorative elements: door and window trim, cornice, and porches.

- As a general rule, proceed to a description of the exterior of any wings or additions before describing the interior of the original

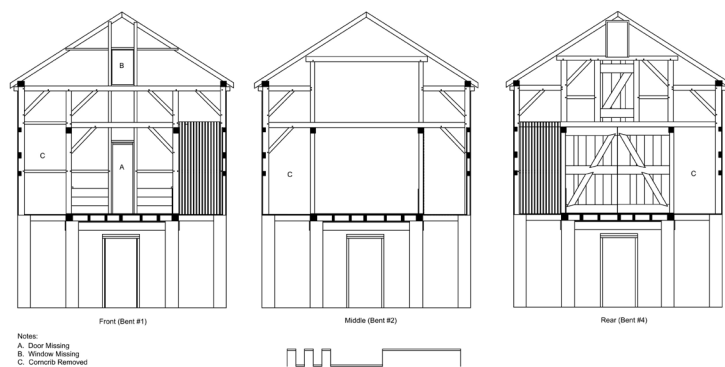

HA-579 Eightrup Corn House, Susquehanna State Park

Section Drawings - Measured by Peter Morrill, Abby Hobbs, Casey Pecoraro, Heather Barnett, Barbara Fisher, and Jessica French. Drawn by Peter Morrill - December 2018

section. The exception would be an extremely complex house that defies orderly description. In this case, it is often easier to describe the principal section, or main block, in its entirety and then move to later sections, which should have been briefly described in the introductory paragraph.

- Describe the interior of the main structure in detail.
  - ▶ Begin with the first floor, and always start by describing the floor plan. Use conventional terminology.
  - ▶ After describing the plan, proceed in a logical order from room to room. In a central passage house, for example, describe the stair passage first, then the rooms to one side (front to rear), then the rooms to the other side. In a hall-parlor plan house, describe the larger, more public hall first, then the parlor. Room descriptions should, where possible, include major features (staircases, fireplace, mantel, cupboards, paneling, decorative trim, baseboard, chair rail, cornice, door and window architraves), doors and hardware, original or altered flooring, early heating stoves, decorative plaster ceiling medallions, etc.
  - ▶ Describe each successive floor in a logical order. It is usually best to begin with the first floor and move up to the attic, then describe the cellar, if one exists. Upper floors are often similar to the first story but become simpler in detail as you move away from the first floor.
  - ▶ The attic description should, where possible, include a description of the principal construction details of the roof, including evidence of the date (and possible sequence) of construction.
  - ▶ The cellar description should, where possible, include the plan, visible construction details, and a discussion of any evidence of room use (cooking fireplaces, early shelving, hanging hooks, barred windows, lattice partitions, etc.)
- Describe the interior of any wings or additions. Particular attention should be paid to the spatial and functional relationship of the wing to the house. For example, was this a service wing for cooking and dining? Is there evidence of segregated living space for servants or farm laborers (i.e., a separate ladder or stair to rooms over the kitchen that has no direct access to the house) or other functions?
- After the house has been described, move out into the yard. Describe any outbuildings or farm buildings that are considered significant, as well as historic landscape features (terraced gardens, fully mature plantings, the family cemetery, etc.).



#### **Other issues to be discussed in Section 7 include:**

- Deterioration due to vandalism, neglect, lack of use, or weather, and the effect it has had on the property's historic integrity.
- For **moved properties**:
  - ▶ Date of move;
  - ▶ Descriptions of location, orientation, and setting historically and after the move;
  - ▶ Reasons for the move (if known);
  - ▶ Method of moving; and
  - ▶ Effect of the move and the new location on the historic integrity of the property.



- For **restored and reconstructed buildings**:
  - ▶ Date of restoration or reconstruction;
  - ▶ The historical basis for the work done;
  - ▶ The amount of remaining historic material and replacement material;
  - ▶ The effect of the work on the property's historic integrity; and
  - ▶ For reconstructions, whether the work was done as part of a master plan.
- For **properties where landscape or open space adds to the significance or setting of the property**, such as rural properties, college campuses, or the grounds of public buildings:
  - ▶ The historic appearance and current condition of natural features; and
  - ▶ Land uses, landscape features, and vegetation that characterized the property during the period of significance, including gardens, walls, paths, roadways, grading, fountains, orchards, fields, forests, rock formations, open spaces, and bodies of water.
- For **industrial properties where equipment and machinery are intact**:
  - ▶ The types, approximate date, and function of machinery; and
  - ▶ Their relationship to the historic industrial operations of the property.
- For **scenic roadways or viewsheds**:
  - ▶ The historic appearance and current condition of both man-made features (such as bridges, buildings, farms, villages) and natural features throughout the area; and
  - ▶ Land uses, features, and vegetation that characterized the roadway during its period of significance.
- For **architectural and historic districts**:
  - ▶ Natural and man-made elements comprising the district, including prominent topographical features and structures, buildings, sites, objects, and other kinds of development.
  - ▶ Architectural styles or periods represented and predominant characteristics, such as scale, proportions, materials, color, decoration, workmanship, and quality of design.
  - ▶ General physical relationship of buildings to each other and to the environment, including facade lines, street plans, squares, open spaces, density of development, landscaping, principal vegetation, and important natural features. Any changes to these relationships over time. Some of this information may be referred to on the Resource Sketch Map but should still be described in the narrative.
  - ▶ Appearance of the district during the time when the district achieved significance and any substantial changes or modifications since.
  - ▶ General character of the district, such as residential, commercial, or industrial, and the types of buildings and structures, including outbuildings and bridges, found in the district.
  - ▶ General condition of buildings, including alterations, additions, and any restoration or rehabilitation activities.
  - ▶ Identity of the buildings, groups of buildings or other resources that do and do not contribute to the district's significance in the form of a list or coded sketch map.
  - ▶ Individually describe the most important contributing buildings, sites, structures, and objects. Characterize in general terms the common kinds of other contributing resources; describe representative examples.
  - ▶ Qualities distinguishing the district from its surroundings.
  - ▶ A chart listing every resource within the defined boundary for ALL survey or historic districts. At a minimum, the chart should list historic name (if applicable) or resource type (i.e. House or Commercial Building), property address, and recommended contributing or non-contributing status. Depending on the project, you may elect to add additional information such as architectural style, construction



date, and/or a brief property description. Please consult with MHT staff to determine the appropriate level of information for your particular project.

- ▶ Any open space such as parks, agricultural areas, wetlands, and forests, including vacant lots or ruins that were the site of activities important in history or prehistory.
- For **industrial districts**:
  - ▶ Outline industrial activities and processes, historic and current, within the district; describe important natural and geographical features related to these processes or activities, such as waterfalls, quarries, or mines.
  - ▶ Original and other historic machinery still in place.
  - ▶ Linear systems within the district, such as canals, railroads, and roads, including their approximate length and width and the location of terminal points.
- For **rural districts and cultural landscapes**:
  - ▶ Geographical and topographical features such as valleys, vistas, mountains, and bodies of water that convey a sense of cohesiveness or give the district its rural or natural characteristics.
  - ▶ Examples and types of vernacular, folk, and other categories of architecture, including outbuildings, within the district.
  - ▶ Man-made features and relationships making up the historic and contemporary landscape, including the arrangement and character of fields, roads, irrigation systems, fences, bridges, and vegetation.
  - ▶ The historic appearance and current condition of natural features such as vegetation, principal plant materials, open space, cultivated fields, or a forest.



## Section 8: Significance

Mark “x” in the appropriate spaces that apply to the property in terms of period and areas of significance. More than one area can be selected based on the history of the property over time.

**Period of Significance:** Enter the dates for one or more periods of time when the property attained significance. For some properties, the period of significance can be as brief as a year, whereas others may span many years and consist of beginning and closing dates. Base the period of significance on specific events directly related to the significance of the property.

**Areas of Significance:** Mark all areas of significance that are directly related to the property. Only enter those areas that are supported and justified by the narrative statement. For districts, enter areas of significance applying to the district as a whole. If no category applies to the property, mark “other,” and identify the area in which the property attained significance.

The area of significance relates to the property’s contributions to the broader patterns of American history, architecture, archeology, engineering, or culture. The area of significance may differ from the historic function. The terms are defined below:

**Agriculture** The process and technology of cultivating soil, producing crops, and raising livestock and plants.

**Architecture** The practical art of designing and constructing buildings and structures to serve human needs.

**Archeology** The study of prehistoric and historic cultures through excavation and the analysis of physical remains.

**Art** The creation of painting, printmaking, photography, sculpture, and decorative arts.

**Commerce** The business of trading goods, services, and commodities.

**Communications** The technology and process of transmitting information.

**Community Planning/Development** The design or development of the physical structure and communities.

**Conservation** The preservation, maintenance, and management of natural or man-made resources.

**Economics** The study of the production, distribution, and consumption of wealth; the management of monetary and other assets.

**Education** The process of conveying or acquiring knowledge or skills through systematic instruction, training, or study.

**Engineering** The practical application of scientific principles to design, construct, and operate equipment, machinery, and structures to serve human needs.



**Entertainment/Recreation** The development and practice of leisure activities for refreshment, diversion, amusement, or sport.

**Ethnic Heritage** The history of persons having a common ethnic or racial identity.

**Exploration/Settlement** The investigation of unknown or little known regions; the establishment and earliest development of new settlements or communities.

**Health/Medicine** The care of the sick, disabled, and handicapped; the promotion of health and hygiene.

**Industry** The technology and process of managing materials, labor, and equipment to produce goods and services.

**Invention** The art of originating by experiment or ingenuity an object, system, or concept of practical value.

**Landscape Architecture** The practical art of designing or arranging the land for human use and enjoyment.

**Law** The interpretation and enforcement of society's legal code.

**Literature** The creation of prose and poetry.

**Maritime History** The history of the exploration, fishing, navigation, and use of inland, coastal, and deep sea waters.

**Military** The system of defending the territory and sovereignty of a people.

**Performing Arts** The creation of drama, dance, and music.

**Philosophy** The theoretical study of thought, knowledge, and the nature of the universe.

**Politics/Government** The enactment and administration of laws by which a nation, state or other political jurisdiction is governed; activities related to political process.

**Religion** The organized system of beliefs, practices, and traditions regarding mankind's relationship to perceived supernatural forces.

**Science** The systematic study of natural law and phenomena.

**Social History** The history of efforts to promote the welfare of society; the history of society and the lifeways of its social groups.

**Transportation** The process and technology of conveying passengers or materials.

**Other** An area not covered by the above categories.

**Specific Dates:** Enter the specific year(s) of the event(s) or association(s) for which the property is significant. As noted above under Period of Significance, for a property important for its architectural character, only the date of construction or major alterations will be included. For significance acquired by associations with a person or event, list only the specific date of the occupation of the property or specific date the event occurred. If a property is significant for more than one reason, the Specific Date will be multiple years. If not enough information is known about the property to list specific dates, enter Unknown.

**Construction Dates:** Enter the date of construction and date of any major alterations for the main resource. If the exact construction date is not known, use a “circa” (ca.) date or specify to the nearest quarter of a century. If not enough information is known about the property to list specific dates, enter Unknown.

**Architect/Builder:** Enter the name of any known architect (individual or firm, builder, designer, landscape architect, engineer, or artist primarily responsible for the design or construction of the property. Identify the individual’s role after the name (i.e., John Smith, builder). If a building’s plan is from a pattern book or catalogue, enter the name of the publication. This space is not for the name of the person for whom the property was developed. If the design source is not known, write “unknown.” For more information on architects and builders in Maryland, consult the Maryland Historical Trust library.

**Evaluation:** If the purpose of this form is to determine a property’s eligibility for the National Register of Historic Places or the Maryland Register of Historic Properties, check the appropriate line. For compliance projects, the evaluation should then be completed on a *Determination of Eligibility (DOE) Form* and submitted with the MIHP form. The preparer should consult the Guidelines for Compliance-Generated Determinations of Eligibility (DOEs) found at: <https://mht.maryland.gov/projectreview/project-review-DOE-Guide.aspx>. Questions concerning the DOE forms should be directed to the Administrator of Project Review and Compliance, or the staff person overseeing that particular project review. The DOE process should be completed in consultation with the Preservation Officer reviewing the project.

On the DOE form, the preparer should address all applicable evaluation criteria for which the property is significant. If the property is determined not eligible, each criterion must be addressed with a justification for lack of significance. Include an objective discussion of the property’s integrity as it relates to its eligibility. Avoid using the term “potentially eligible.” See below under, “Applicable Criteria for Evaluation,” for more information. In Section 8 of the inventory form, the preparer should proceed with a concise discussion of the significance of the resource, addressing the applicable criteria in a summary statement and then, providing a narrative discussion of the history of the resource and its context.

If the purpose is mainly to identify and document the property (including most grant-funded projects), mark “not evaluated.” Unless a Determination of Eligibility form is also being prepared, “not evaluated” should be marked. Nevertheless, the preparer should discuss the significance of the resource by providing a statement of significance that addresses the applicable criteria and continues with a narrative discussion of the history of the resource and its context.

All criteria under which this property is significant must be explained in the significance statement. The statement may address a criterion that may potentially apply but sufficient information is currently lacking to support evaluation. The preparer should note that more information is needed before that criterion can be marked as part of a determination of eligibility.

**Applicable Criteria for Evaluation:** The criteria used for evaluating properties for the National Register of Historic Places are designed to guide state and local governments, federal agencies, and others in evaluating properties for eligibility for the National Register.

The quality of significance in American history, architecture, archeology, engineering, or culture is present in those districts, sites, buildings, structures, and objects that possess integrity of location, design, setting, materials, workmanship, feeling, and association, and

- a) are associated with events that have made a significant contribution to the broad patterns of our history; or
- b) are associated with the lives of persons significant in our past; or
- c) embody the distinctive characteristics of a type, period, or method of construction; represent the work of a master; possess high artistic value; represent a significant and distinguishable entity whose components may lack individual distinction; or
- d) have yielded, or may be likely to yield, information important in prehistory or history.

**Applicable Exception (Consideration):** The criteria exceptions or considerations are part of the National Register criteria and set forth special standards for listing certain kinds of properties that are usually excluded from the Register. The applicable exception should be marked on the DOE form for all compliance projects. If the project is an evaluation of the resource for eligibility but will not be submitting a DOE form, the *Applicable Exception* should be clearly stated in the narrative statement of significance.

Ordinarily cemeteries, birthplaces, or graves of historical figures, properties owned by religious institutions or used for religious purposes, structures that have been moved from their original locations, reconstructed historic buildings, properties primarily commemorative in nature, and properties that have achieved significance within the past fifty years are not considered eligible for the National Register. However, such properties will qualify if they are integral parts of districts that do meet the criteria or if they fall within the following categories:

- a) a religious property deriving primary significance from architectural or artistic distinction or historic importance; or
- b) a building or structure removed from its original location but which is significant primarily for architectural value, or which is the surviving structure most importantly associated with a historic person or event; or
- c) a birthplace or grave of a historical figure of outstanding importance, if there is no other appropriate site or building directly associated with his productive life; or
- d) a cemetery that derives its primary significance from graves of persons of transcendent importance, from age, from distinctive design features, or from association with historic events; or
- e) a reconstructed building when accurately executed in a suitable environment and presented in a dignified manner as part of a restoration master plan, and when no other building or structure with the same association has survived; or
- f) a property primarily commemorative in intent, if design, age, tradition, or symbolic value has invested it with its own historical significance; or
- g) a property achieving significance within the past fifty years, if it is of exceptional importance.

**Statement of Significance:** Provide a narrative stating the significant qualities and associations that make the property important. Begin with a summary paragraph that briefly explains why the property is significant in the areas marked and how it meets selected criteria. In additional paragraphs, provide information to support your assertions regarding the significance of the resource. Include a discussion of the historical context in which the resource has been studied and the evaluative information that explains its significance in relation to other properties of its type within precisely defined geographic boundaries, such as a neighborhood, city, county, region, state, or the nation.

Include background information on events, development of the property (i.e., date of construction, factors leading to the construction, etc.), and biographical data on persons associated with the property. If available, also include an evaluation of the importance of the property in architectural history, and/or an assessment of the types of information the property may be expected to provide.



Employ primary sources for research whenever possible and carefully document all sources of information. Use footnotes to indicate sources, and provide photocopies of key source documents, chain of title, etc., where appropriate. While parenthetical or in-text citations are also acceptable, please note that footnotes are preferred. Be consistent when indicating sources and do not switch between footnotes and other formats such as parenthetical or in-text citations within the narrative. In all cases, follow the most recent edition of *The Chicago Manual of Style*.

### *Completing the Resource History*

Documentary research in libraries, archives, and other facilities can provide both primary and secondary architectural and historical information. Several of the most basic archival sources that describe known historic structures, sites, and objects and their locations are the Maryland Inventory of Historic Properties, the National Register of Historic Places, and lists of sites for which determinations of National Register eligibility have been made. Note also that archeological sites included in the Maryland Inventory and the National Register may also indicate the possibility of architectural and historic resources from the historic period. Published and unpublished reports or surveys in or near the current project area are also essential sources. Other documentary materials, which can be useful in locating potentially significant architectural and historic properties, depending on the nature of the undertaking and project tract, include:

- historic maps and atlases, including early U.S. Geological Survey quadrangles;
- insurance records and maps;
- publications on local history;
- building permits;
- tax maps;
- publications on the nature and significance of the general property type;
- early lithographs and photographs;
- court records (deeds, mortgages, etc.);
- real property records;
- ordinances and resolutions;
- transportation records (i.e., ship manifests for a port);
- wills and probate inventories;
- census data;
- oral histories;
- family histories (published and unpublished).

Informant interviews are another potential source of data on a project area's architectural and historic resources. Contacting people who live or work near a study site can yield very specific data on historic sites or standing structures and past land use. Preliminary field visits will establish a network of local contacts; and meetings with local historical societies, civic associations, and/or citizen groups can provide access to an array of knowledgeable individuals. MHT staff can provide the names of contact persons and may, in some instances, possess additional project-specific architectural and historical information.

Together, informant interviews and documentary research assist in predicting the number, location, and nature of cultural





resources in a study area. Additionally, these activities enable the refinement of appropriate historic contexts for the interpretation of new architectural and historical structures, sites, and objects. Fully developed contexts are the basis for well-reasoned discussions of the potential significance of the resources with respect to important research issues and comparative data from similar historic properties.

Important facilities for conducting archival and background research are:

- Maryland Historical Trust Library
- Maryland Historical Trust's online database known as Medusa
- Maryland State Archives, Hall of Records
- Enoch Pratt Free Library
- Maryland Historical Society
- University of Maryland at College Park, Maryland Room and architectural library, Hornbake Library
- National Trust for Historic Preservation Library, Hornbake Library, UMCP
- Smithsonian Institution
- National Archives and Records Service
- Library of Congress
- University and public libraries
- Local museums and historical societies
- County and municipal government offices.

### *Section 9: Major Bibliographical References*

Enter the primary and secondary sources of information used in documenting and evaluating this property. These may include land records, published works, oral interviews, library and historical society files, photograph collections, and drawings. Do not include general reference works, unless they provide specific information about the property or have assisted in evaluating the significance of the property.

The format for bibliographical entries should be clear and consistent and follow the most recent edition of the *Chicago Manual of Style*. Use a continuation sheet if necessary. Within the narrative in Section 8, please note that footnotes are preferred over parenthetical or in-text citations and should be used consistently to indicate sources.

### *Section 10: Geographical Data*

**Acreage of Surveyed Property:** Enter the total number of acres surveyed. This may be the acreage to which the present owner(s) hold(s) title, otherwise known as the tax parcel boundary; the Area of Potential Effect for a large study area; or boundaries determined by the surveyor. The acreage should include all of the land surveyed, even if large sections contain no historic resources—but only if the entire area was actually considered. For example, if the inventory form for a 300-acre farm complex includes ten resources grouped within only five acres, it is important to know the surveyor found no other resources in the 300-acre parcel. Thus, the acreage for the surveyed property should be 300 acres. The goal for intensive survey is to carefully study the entire 300 acres to determine the extent of historic resources within the entire area. However, if it is not possible to verify the existence or non-existence of resources within the larger area, the preparer must include only five acres as the acreage surveyed. Discuss the area of coverage within Section 7. For a compliance project, the Area of Potential Effect should encompass the entire project area. Acreage should be accurate to the nearest whole acre. For properties of less than one acre, round to the nearest quarter or tenth of an acre, as appropriate. If the exact acreage is unknown, a close approximation must be given. The National Park Service requires this information for SHPO reporting, and must be included on the form. Please do not provide acreage in square feet.

**Acreege of Historical Setting:** This refers to the property historically associated with the resource(s). In many cases, the significant elements of a historic resource will occupy an area that is different from—usually smaller than—the total area surveyed. For example, the 300-acre farm complex mentioned above is comprised of ten buildings and structures related to the farmstead within only five acres. It is surrounded by 295 acres of fields and woods on which no additional resources are found. In this case, the historical setting would be five acres with an explanation in the verbal boundary description and justification (see below). The significance of the landscape or setting may increase the acreage, and should be addressed more carefully in Section 8. Using the same example, the historic setting may be expanded to include the 50 acres of historic fields, including hedgerows and other field delineations, surrounding the farm. In a compliance project, an Area of Potential Effect might cover several square miles within which a series of historic resources, each with a definable historic acreage, can be identified. The historic setting would include only the definable acreage associated with the resources. For inventory forms used for a determination of eligibility, the acreage should include only the area being evaluated.

**Quadrangle Name and Scale:** List the name of the United States Geological Survey quadrangle map upon which the property is located. The quadrangle scale used by the Maryland Historical Trust is 1:24,000.

**Verbal Boundary Description and Justification:** Describe both the survey and historical setting boundaries of the property. A legal parcel number or block and lot number, a sequence of metes and bounds, or dimensions may be used; or refer to an attached map. Provide a brief and concise explanation of the reasons for selecting the survey boundaries. Discuss how these differ from the historical setting, and provide a justification for the latter boundary. Also, list all states or counties for properties overlapping state or county boundaries. A continuation sheet may be used, if necessary.

### *Section 11: Form Prepared by*

Enter the name, title, organization, address, and daytime telephone number of the person(s) who compiled the inventory form. This section is intended to credit authorship of the form and identify a person who can be contacted if a question arises or if additional information is needed. If different persons prepared the description and significance sections, identify the preparer of each part. If multiple authors contributed to the form, you may prefer to list only one person as coordinator with the other contributors acknowledged in the bibliography section. Also enter the date the form was completed. If the form is completed long after the property was inspected, include the date of the field inspection as well.

## **Accompanying Documentation**

*All accompanying documentation should be labeled with the inventory number at a minimum. Each subsection below contains labeling instructions for that component.*

**Capsule Summary:** Each Maryland Inventory of Historic Properties form must be accompanied by a capsule summary for inclusion with the inventory form. The summary should include a brief one- to two-paragraph description of the property noting its overall appearance, any key characteristics of the resource(s), a statement of significance, and a summary paragraph on the history of the resource in its context. This must be typed, double-spaced, on plain white 8½" × 11" acid-free paper. In the top left margin, type a heading that includes the name of the property, MIHP number, location, town or town vicinity in which the property is located, approximate date of construction, and access (public or private).



**Continuation Sheets:** Use continuation sheets when the space on the inventory form is insufficient to enter all the information necessary for documenting the property. A header for continuation sheets has already been created on the inventory form. If used, fill in the inventory number in the top right-hand corner of the page, the name of the property, and the number of the section being continued.

Number the pages according to the section being continued in the space that is provided. The electronic version will automatically number sheets for Sections 7 and 8. Note on the inventory form in the appropriate sections the number of the continuation sheet on which the information is continued.

**Chain of Title:** Place on a separate sheet of paper using Microsoft Word (not on a continuation sheet). The header should include the inventory number, name of property, town/vicinity, and county. The formatting of this information is at the discretion of the consultant.

**Photographs:** For each property recorded on an inventory form for a grant-funded or National Register nomination project, submit clear and illustrative black-and-white or color photographs. Check individual project requirements for the number of sets of photographs to be provided. You may use a 35mm single-lens reflex (SLR), a large format camera, or a digital SLR camera able to produce photographs with a pixel array of at least 3000 × 2000 at a resolution of 300 ppi or larger. All photographs should be in the form of prints at least 5" × 7" in size. Smaller size prints will not be accepted.

While prints are still desirable, MHT will accept embedded black and white or color images on continuation sheets for non-grant funded projects. See example in Appendix B for formatting. Embedded photos should be sized to approximately 4" × 6" when oriented horizontally. Ideally, when inserting horizontal images, you should be able to fit two per page.

The photographs should be recent and should be a true visual representation of the historical integrity and significant features of the property. The number of photographic views will vary according to the size and complexity of the property. Take as many photographs as needed to show the current condition and significant aspects of the property. However, when submitting a large number of photographs, limit the number to no more than

20 prints or images on continuation sheets, with the remainder submitted digitally. You may elect to print a smaller number of photographs for exceptionally complex resources and include additional digital image files on the accompanying archival CD. Include representative views of both contributing and non-contributing resources. Copies of historic photographs may supplement documentation and may be particularly useful in cases where alterations make a property's historic integrity questionable. Photographic prints of historic views are preferred; photocopies may be acceptable. For additional information on digital submissions, please see Appendix C, Standards for Submission of Digital Images to the Maryland Inventory of Historic Properties.

Guidelines relating to the number and types of photographs for individual properties and districts are listed below.

### **Buildings, Structures, and Objects**

Submit one or more views to show the principal facades and the environment or setting in which the property is located.

- Additions, alterations, intrusions, and dependencies should appear in the photographs.
- Include views of interiors, outbuildings, landscaping, or unusual details if the significance of the property is entirely or in part based on them.



- If the property includes a number of resources, such as a farmstead, key the photographs to a sketch map of the property.

### Survey and Historic Districts

MHT distinguishes between an area, a village, a community, or town surveyed for inclusion in the Maryland Inventory of Historic Properties and historic districts listed in the National Register of Historic Places. For the purposes of the Inventory, MHT prefers to use the term ‘survey district’ when referring to areas that are not National Register-listed historic districts or areas that have not been formally determined eligible.

Submit photographs representing the major building types and styles, pivotal buildings and structures, representative non-contributing resources, and any important topographical or spatial elements defining the character of the district.

- Provide overall streetscape, landscape, or aerial views showing the resources in context, as well as views of representative individual properties within the district. Views of individual buildings are not necessary, if streetscapes and other views clearly illustrate the significant historical and architectural qualities of the district.
- Key all photographs to the Resource Sketch Map for the district or prepare a separate photograph map.



### Photograph Labeling

The subject of each photograph must be written legibly on the back of the print. Use a soft graphite (lead) pencil to label photographs, such as the Stabilo All 8008. It may be difficult to write on resin-coated photographic paper with many pencils, however, soft grades such as #1, commonly available in office-supply stores, or #4B, #5B, sold in art-supply stores, work well. Do not use china marking or grease pencils, as their waxy medium will smudge and transfer to the surface of other prints. Felt-tip markers are not acceptable. Although MHT prefers soft graphite pencil for labeling, we will accept photographs labeled with archival pens such as Pigma or Kaiser CD [R] pens. MHT staff will test all ink used for labeling prints; if we find the ink unacceptable (non-archival), the photos will be returned to the preparer for reprinting at consultant’s expense.

Provide the following information on the back of each photograph:

- Maryland Inventory of Historic Properties (MIHP) number
- Name of photographer
- Date of photograph
- Photograph numbers should be assigned sequentially (i.e. #1 of 7 or 1/7).

In addition to the above information, please include a photo log as a continuation sheet in the MIHP documentation that contains the description of view indicating direction of camera. For example, Photo 1 of 10: Front Façade, facing north. If you elect not to include a photo log and are only labeling the backs of the photographs with the above information, you must include the description of the view above the photograph number.

Use archival storage pages for submitting photographs to the Trust. These must be heavyweight polypropylene pages with two side-loading pockets in 5" x 7" format that fit a standard three-ring binder. Vinyl or polyvinyl chloride (pvc) sheets are not acceptable. Photo sleeves are available through archival photographic storage companies, such as C-Line. Place the photographs in the storage pages in a logical sequence, showing views of the overall setting, the exterior, the overall interior, specific rooms, details, and finally all



secondary resources. Insert only two photographs per page. Do NOT place photographs back to back so that four photographs are stored in one page. Please do not label (or otherwise write on) the photo sleeve pages themselves.

**Locational Map:** The Trust's standard base map is the United States Geological Survey topographic quadrangle map at 1:24,000-scale. The USGS maps created in the period between 1884-2006 were originally published as paper documents and are available as scanned images, now referred to as "historic maps" in order to distinguish between the current-generation topographic maps that are created from digital GIS databases and branded "US Topo." The late 20th century USGS topographic quadrangle map is preferred to the current-generation.

Submit two maps sized to fit on 8½" × 11" inch paper using the appropriate section of the late 20th century USGS topographic quadrangle maps, with the first map indicating the overall location of the property at 1:24,000-scale (1 inch = 2,000 feet) and the second map clearly depicting the exact boundary of the survey area at a zoomed-in view of the same map, such as at 1:12,000-scale. For urban properties, a current tax, block, and parcel map should be included along with the USGS quad map. Aerial imagery can be submitted along with, but not as a substitute for, the USGS topographic quadrangle maps. For incorporated towns and cities, prior approval of base map is required. For regulatory surveys that make a determination of eligibility, the map should clearly define the property boundaries and eligible resource, if different. Each map should include a north arrow, scale and a title block that lists the inventory number, property name, town or town vicinity, county, and map or quadrangle name (adhesive labels are not acceptable).

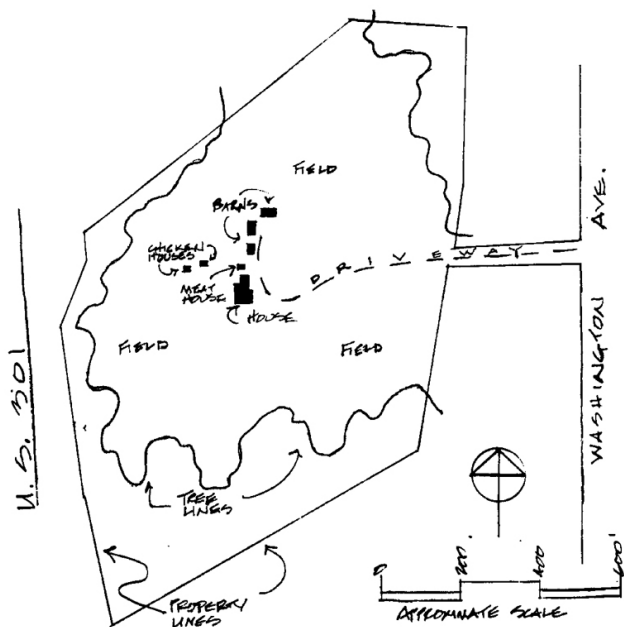

**Resource Sketch Map:** If the property contains a number of buildings, structures, objects, and/or sites, prepare a map that illustrates the approximate location of these resources within the boundaries of the property and clearly identifies contributing and non-contributing resources as well as their use. This map does not have to be drawn to scale. The map must be labeled with the inventory number, name of property, town or town vicinity, county, a north arrow, and the title *Resource Sketch Map* (adhesive labels are not acceptable).

**Historic Maps:** Historic maps should be included when possible, with the property clearly marked on an 8½" × 11" photocopy. Label the map, including the inventory number, name of property, town or town vicinity, county, north arrow, date, and source of the historic map (adhesive labels are not acceptable).

**Measured Drawings:** When possible, provide a plan of the room arrangement of the principal building(s) that characterize the property. Draw the plan to fit an 8½" × 11" sheet of paper. The plan need not be drawn to precise scale, but it should be generally proportional and should indicate overall exterior dimensions. It may be drawn either free hand, hardline, or using CAD or SketchUp but must be clear and detailed.

The plan should illustrate the principal floor, generally the first floor, and should include additions, porches, etc. Denote arrangement of rooms, chimney or fireplace locations, and the placement of stairs, doors, and windows. Use conventional symbols to represent these elements.



When the significance of the resource is based on its architectural character or if the resource is complex, prepare measured floor plans. These may be annotated field drawings, in pencil, at ¼" scale, and should include at least the principal floor plan. If warranted, include other floor plans, sections, elevations, or details. If appropriate, prepare larger scale drawings. Label each plan with the inventory number, name of the property, town or town vicinity, county, year drawn, the delineator, and the floor represented. For specific requirements for compliance project drawings, refer to the applicable "Memorandum of Agreement" or recordation requirements.

**Addenda:** If the original inventory form was adequate and provided good documentation or the current project will only update current conditions, prepare addenda to update the existing forms. If, however, the existing form is inadequate, is reconnaissance level, or requires extensive correction, prepare a new form. Consultation with Trust staff is recommended before an addendum is completed. Include an addendum when, for example, a MIHP form documents the main house of a complex but not the outbuildings; an existing intensive form was prepared for a property that has since been significantly altered; or a surveyed property was not evaluated.

The addendum form can be found under the Research and Survey tab, "Forms and Documents" on the MHT website. Addenda should contain all new information in a narrative format. If updating the entire form, follow and change the existing information in logical order. If a change is necessary (i.e., if there is a new owner) list Section 3 as an addendum and give the current information. If the addendum is only updating Sections 7 and 8, the new narrative text should follow the continuation-sheet format for section and page number information.

### *Submittal of Documentation*

*Please note: Documentation that does not meet all of the above requirements will be returned for revision. Review will not proceed until all requirements are met. See Appendix C for a helpful checklist for the proper submission of final MIHP forms.*

Submit all Maryland Inventory forms and accompanying documentation to the Trust in a standardized manner. The required order follows the way the inventory forms are stored in the inventory notebooks at the Trust library. Once the information has been reviewed and accessioned into the library, the Trust will return the preparer's packaging materials upon request. For further guidance on accessioning procedures, please refer to Chapter VIII, Accessioning Procedures. Specific questions on submitting survey documentation materials should be addressed to the Inventory Registrar.

All forms and accompanying documentation must be three-hole punched, and submitted to the Trust in a binder (3" or smaller). Individual forms need not be placed in a binder, but must be hole-punched. Place photographs in appropriate archival storage pages at the end of the property's documentation. Place the final survey report in front of the individual forms. Arrange the forms in the following order: capsule summary, the four main pages of the inventory form with continuation sheets placed directly behind each section in sequential order, figures, drawings, maps, photo log, and photographs.

#### **SUBMIT COMPLETED FORMS, ALONG WITH A COVER LETTER, TO:**

Office of Research, Survey, and Registration  
Attn: Architectural Survey Administrator  
Maryland Historical Trust  
100 Community Place, 3rd Floor  
Crownsville, Maryland 21032-2023

SUBMIT COMPLIANCE DOCUMENTATION, ALONG WITH A COVER LETTER, TO:

Office of Preservation Services  
Attn: Administrator, Project Review and Compliance  
Maryland Historical Trust  
100 Community Place, 3rd Floor  
Crownsville, Maryland 21032-2023

If you are working on grant-funded or compliance projects, submit documentation directly to your Project Monitor or Preservation Officer.

# V *Guidelines for Completing National Register Nomination Forms for Maryland Properties*



## Introduction

The National Register of Historic Places is the federal government's official list of properties worthy of recognition and protection for their capacity to reflect a significant aspect of American history and culture. A program of the National Park Service, the National Register is administered in Maryland by MHT. The MIHP and the NR differ in significant respects. Most importantly, while the MIHP is a broad catalog of historic properties that does not involve evaluative judgment, inclusion in the National Register requires that a property meet specific criteria for significance and integrity, and specifies a multi-level review process to support that evaluation. Because all properties listed in the NR are also automatically included in the MIHP, the details of the documentation must satisfy the technical requirements of both programs. The following chapter will address the specifics of preparing National Register nomination documentation for Maryland properties.

## Step One: Discuss your proposed nomination with MHT staff

National Register nominations require a substantial level of research and preparation. Therefore, we strongly encourage prospective preparers to contact MHT's National Register staff to discuss the property's likelihood for success in listing before investing significant time and effort in developing the documentation. MHT staff can advise on the property's potential eligibility for the NR, and can also suggest the most appropriate directions to focus research. Contact MHT's Administrator of Evaluation and Registration at (410) 697-9562.

## General Instructions for Completing National Register Documentation

The documentation required for the National Register of Historic Places (NRHP) is similar in many respects to the Maryland Inventory of Historic Properties (MIHP) – in fact, the MIHP form was originally modeled on the NR form. The above guidance for completing the MIHP form is, for the most part, equally applicable to the NR form. Areas where the programs differ are addressed below.

National Register nominations must be completed on the National Register Registration Form, NPS Form 10-900 (aka "*NR Form*"), available at <https://www.nps.gov/subjects/nationalregister/upload/NPS-Form-10-900-NRHP-Registration-Form.docx>

Detailed instructions for completing the NR form are provided by the National Park Service (NPS) at: <https://www.nps.gov/subjects/nationalregister/upload/NRB16A-Complete.pdf> (National Register Bulletin 16A, How to Complete the National Register of Historic Places Registration Form, aka "*NR How-to*").

## *Multiple Property Submissions (MPS)*

The National Register also offers a format for nominating multiple properties that share common attributes or themes. In this format, the historic context and registration requirements are detailed on a Multiple Property Documentation Form (MPDF), and related properties are documented on individual Registration Forms. This allows for an efficient and open-ended approach, as the context statement need not be repeated on each registration form, and additional related properties may be nominated at any time. Information on the Multiple Property Format, and relevant forms, may be found here:

- <https://www.nps.gov/subjects/nationalregister/upload/NRB16B-Complete.pdf>
- <https://www.nps.gov/subjects/nationalregister/upload/NPS-Form-10-900b-NRHP-Multiple-Property-Documentation.docx>

The specifics of utilizing the MPS format are beyond the scope of this document. Anyone contemplating a project that may benefit from the Multiple Property approach should contact MHT's Administrator of Evaluation and Registration for direction and assistance.



## **Completing the National Register Registration Form**

Carefully read this entire document and the *NR How-to*. The Standards and Guidelines offer especially valuable guidance on substantive issues concerning the description, statement of significance, and resource history. The *NR How-to* specifies the technical requirements for NR forms.

*Important: MHT's requirements for NR nominations differ from those outlined in the NR How-to in certain areas. After filling in the blanks on the NR registration form as directed in the NR How-to, refer to MHT requirements as noted below within the relevant section of the NR form.*

### **Name of Property**

- Follow instructions in *NR How-to*.
- Insert MIHP number under "Other names/site number," and in the header of every page that follows.

### **Location**

- Follow instructions in *NR How-to*.

### **State/Federal Agency Certification**

- Leave this section blank

### **National Park Service Certification**

- Leave this section blank

### **Classification**

- Follow instructions in *NR How-to*.
- Under "Number of contributing resources previously listed in the National Register" do not leave the space blank; insert 0 if none.

### **Function or Use**

- Follow instructions in *NR How-to*.

### **Description**

- Follow the prompts on the *NR Form* and instructions in *NR How-to*.
- See MIHP guidance for writing and organizing description.

- For Historic Districts, provide a table or list that identifies all properties within the district boundary by address or tax parcel, and includes a brief description of each, along with an indication whether the property contributes to the significance of the district or does not (C or NC). Property descriptions must include, at minimum, the property type (and style, if applicable), major materials, and approximate construction date.

### Statement of Significance

- Follow the prompts on the *NR Form* and instructions in *NR How-to*.
- The Summary Paragraph must explicitly address how the property meets NR criteria. “[Name of Property] meets National Register Criterion [blank] in the area [insert Area of Significance here] because . . .” Also address issues of integrity: “the property retains integrity to convey its significance because . . .” If any of the Criteria Considerations apply, explain.
- At the end of the Summary Paragraph, specify, explain, and justify the Period of Significance. “The Period of Significance, 1805-1910, begins with the initial construction of the main house and ends when the property was transferred out of the Ziegelhofer family. During this period it substantially attained its historic form.”
- In the Narrative Statement of Significance, provide information supporting the defined areas of significance. Discuss the history of the property and its historic contexts. The MIHP guidance for preparing a Resource History will be particularly useful here.



### Major Bibliographical References

- Follow instructions in *NR How-to*.
- Insert MIHP number in the blank after “Historic Resources Survey Number (if assigned)”

### Geographical Data

#### Acreege of Property

- Enter the total acreage of the property included in the nomination.
- NR forms need not identify “Acreege of Surveyed Property;” this item is only relevant to the MIHP.
- Enter UTM references or Latitude/Longitude coordinates according to instructions in *NR How-to*.

#### Verbal Boundary Description

- Describe property boundaries by reference to tax parcel map or in metes and bounds. Maps used to document NR boundaries must be at least 1”=200’ in scale.
- For properties with large acreage or complex boundaries, provide a map delineating the area to be included in the National Register. Label this map “National Register Boundary” and refer to it in the Verbal Boundary Description (“The nominated property, X acres, is shown on the map which accompanies this documentation, entitled National Register Boundary.”) If the boundary map is larger than 11” by 17”, provide two copies. For properties that are coterminous with the tax parcel, it is not necessary to provide a boundary map; the Verbal Boundary Description should read “The nominated property is described within the Land Records of X County in Liber Y, folio Z.”



## Boundary Justification

- Follow *NR How-to* instructions for identifying appropriate boundaries (typically, the property historically associated with the resource which encompasses all contributing elements and retains integrity).

## Form Prepared By

- Follow instructions in *NR How-to*.

## Other Required Materials

Submit the following items with the completed *NR Form*:

**Maps:** A **Locational map** (USGS Quad or equivalent, 7.5 or 15 minute series) indicating the property's location as directed for the MIHP. In addition, indicate the Lat/Long coordinates or UTM references in the map label. For properties of ten acres or less, a single point marking the center of the nominated property is adequate; larger properties must be defined by multiple points, following the instructions in the *NR How-to*. Include a **Sketch map** for historic districts and properties having large acreage or numerous resources. Key all photographs to this map.

Other **graphics** such as historic maps and images and/or measured drawings are encouraged, and may be submitted on continuation sheets as Supplementary Documentation.

**Ownership Information:** Property owners are notified of pending National Register nominations, and the NR requires that ownership letters be specifically addressed to an appropriate individual (not "To Whom it May Concern," etc.) Provide the name and mailing address of the current owner(s) of the property. For corporate ownership, provide the name and address of the individual in charge. For historic districts, provide a list of owners of all property within the district boundaries, both contributing and non-contributing, generated from Maryland State Department of Assessments and Taxation records. Indicate the date when the information was compiled.



## Photographs

Submit clear, descriptive, and current photographs. The size of each image must be 1600 × 1200 pixels (minimum), 3000 × 2000 preferred, at 300 ppi (pixels per inch) or larger. Key all photographs to the sketch map. Each photograph must be identified by its file name and number on the photo log. For simplicity, the name of the photographer, photo date, etc. may be listed once on the photograph log and doesn't need to be labeled on every photograph.

Follow the guidance given elsewhere in this document for technical specifications and photographic coverage. Images may be embedded on continuation sheets within the Photo Log section of the NR form.

## Photo Log

MIHP Number: \_\_\_\_\_

Name of Property: \_\_\_\_\_

City or Vicinity: \_\_\_\_\_

County: \_\_\_\_\_ State: \_\_\_\_\_

Photographer: \_\_\_\_\_

Date Photographed: \_\_\_\_\_

Image file name in NR format (MD\_County\_PropertyName\_XXXX.tif)

Brief caption describing view, including direction of camera

Sequential number, e.g., 1 of [total], 2 of [total], etc.

Photo image files must be named according to National Register conventions, as follows:

MD\_County\_PropertyName\_XXXX.tif

Be sure to include the **underscores** within the filename, and assign leading zeroes to the photo number to create four places, as in the examples below:

MD\_BaltimoreCity\_Clifton\_0001.tif

MD\_AnneArundelCounty\_45FleetStreet\_0010.tif

MD\_BaltimoreCounty\_ReisterstownHD\_0100.tif

## Submittal of Documentation

- Submit
  1. one unbound hard copy of the NR form and all accompanying documentation
  2. one archival CD or DVD containing the image files in unmodified .tif format
  3. a separate archival CD or DVD containing the nomination documentation in MS Word format.
- Submit two hard copies of any oversized materials (larger than 11" by 17").
- If photographic prints are submitted, place them in archival sleeves as directed in the MIHP instructions above. Label each print with the information included in the Photo Log.
- Do not punch NR materials, and do not place in a binder.
- Incomplete submittals will not be processed.

SUBMIT NATIONAL REGISTER FORMS, ALONG WITH A COVER LETTER, TO:

Office of Research, Survey, and Registration  
Attn: National Register Administrator  
Maryland Historical Trust  
100 Community Place, 3rd Floor  
Crownsville, Maryland 21032-2023





# VI *Final Survey Reports*



**H**istoric resource surveys and their resulting inventories can form an important basis for planning decisions affecting the quality of life in our communities. The final survey report represents the culmination of a process of identification and gathering of data on a community's historic resources. It includes a field survey, the search for and recording of historic resources, a summary of pre-survey planning and background research, and the establishment of a historical overview of the project area to document the broad patterns of a community's historical development that will be represented by its historic resources.

Basic standards and guidelines for historic preservation surveys have been published as part of the Secretary of the Interior's *Standards and Guidelines for Archeology and Historic Preservation*, and this chapter interprets these standards and guidelines for use in Maryland. The National Park Service requires that all grant-funded projects complete a final survey report that provides a summary of all aspects of the project for future reference. This report differs from a final grant project report, which is primarily administrative in nature, in that it documents the results of identification efforts. These results can then be integrated into the planning process so that any evaluation decisions will be based on the best available information.

## **Final Report Contents**

The final report should convey the thoroughness, consistency, and accuracy of all aspects of the survey. It should clearly summarize and demonstrate the goals and objectives of the survey that provided the foundation for the organization of the historical research and field survey work. A description of the methodology for the completed project should explain how specific historical and cultural information relevant to the development of the survey area was discovered and was related to the field work. The project's results should be described, emphasizing the quality and usefulness of the survey. Finally, a separate statement should address the disposition of all final products of the survey. (See suggested outline, below.)

Organization and review of the survey data is an ongoing process that begins while the fieldwork is in progress. The methods used to compile, evaluate, and store the data will have a direct effect on the usefulness of the inventory for planning purposes. Therefore, it is vital that the inventory forms, field notes, photographs, maps, and other supporting documentation are organized so that the disposition of the survey's final products can be easily described and located by planners and other interested individuals. The suggested organization and components of the final survey report are discussed in the following detailed outline.

## Suggested Content Outline

### Title Page

- Title of report.
- Name, nature, and location (with county) of the project.
- Clear designation of report's author(s) with complete email and mailing address(es).
- Clear designation of project's principal investigator(s) with complete email and mailing address.
- Names and complete mailing addresses of the lead government agency and of the government agent (i.e., engineering firm, developer, or project sponsor, if appropriate).
- Date of current version of report (i.e., latest production date).

### Executive Summary

- This summary—at most one half page long—should cover the survey's purpose, the location of the survey area findings, and recommendations.

### Table of Contents

- Entries with page numbers for all report chapters and headings/sub-headings.
- A figures list including all forms of illustrations (i.e., line drawings, plates) and tables, with page numbers for all figures.

### Introduction

- A brief statement should give the purpose of the historic preservation work.
- Identify the lead governmental agency, or project sponsor, if appropriate.
- Include information on project funding and sources.
- Include locator maps.
- Specify dates when background research and architectural investigations were conducted.
- Record the acres examined.
- Give the number and titles of historic preservation personnel involved.
- Describe the organization of the report.

### Research Design

- For grant-funded surveys, incorporate the revised research design that was previously submitted and approved by MHT.
- Open with a detailed statement of the survey's goals and objectives, including applicability of the work to broader county or regional historic and architectural contexts.
- Describe the methods and techniques used, the archival and background research, the survey, and final analysis, including the intensity of coverage and any changes from proposed research design methodology.
- Summarize the results of the survey and other findings.
- Give the final disposition of field records and research information.

### Historic and Architectural Context (Guidelines for organizing a historical overview of the project area):

- Determine the kinds of events, patterns of development, or activities for which properties meet the National Register criteria. (See the list of areas of significance in Section 8 of the Maryland Inventory of Historic Properties and National Register forms.)
- Carefully analyze the survey area to identify themes in the area's history and within the general areas of significance that represent significant patterns of American



history, architecture, archeology, engineering, and culture and have made significant contributions to the historical development of the locality, state, or nation.

- Identify the concept, time period, and geographical limits for the historic context(s) based on historical research related to theme(s), area(s) of significance, and geographical area.

Base this step on historical documentation of and fieldwork in the survey area. Consider stages and patterns of area settlement and development; aesthetic and artistic values embodied in the architecture or art such as craftsmanship, construction technology, or style; the work of a master; research values or problems related to the area's history; social and physical sciences and humanities; and local cultural interest.

### **Results of Field Investigations**

- The report should include a statement of conditions and constraints that may have affected the fieldwork.
- Include a qualitative and quantitative description and an analysis of the architectural and historic resources with reference to comparable published studies.
- Include maps depicting the locations of identified resources and descriptive illustrations.
- When interpreting field-investigation results, refer to historic contexts and research questions; and address the issue of integrity and/or significance as related to the property's eligibility for the National Register, if possible and appropriate.
- Use official Maryland inventory numbers (i.e., site numbers issued by the Trust's Office of Research, Survey, and Registration) to identify resources in the text and in illustrations of both draft and final reports.

### **Summary and Recommendations**

- Summarize the results and evaluate the survey's methods and techniques.
- Include a statement addressing the eligibility of identified cultural properties for the National Register of Historic Places, and recommendations for future nominations.
- Address the need for additional investigations or resource treatment, if applicable.
- Discuss the study's appropriateness for public interpretation.
- Include recommendations for future work.

### **References Cited**

- The style of all citations should follow the latest edition of *The Chicago Manual of Style*.

### **Appendices**

- Include an index that identifies all sites surveyed and include the inventory number, building name, specific address or location, and town for each resource.

### *Final Report Format*

*Original inventory forms, maps, and photographs must be submitted separately and should not be placed in the bound report.*

All final reports submitted to the Trust for review should consist of spiral bound, 8½" x 11" single-spaced, double-sided, typed pages. Three-ring binders are not acceptable. The final report must be submitted on acid-free paper, along with an electronic copy on archival disc. Figures or maps may be larger in size for clarity, if they can be folded to fit in the bound report as pages or inserts in a pocket. Property survey data should be submitted on the official inventory form, which is not bound in the report. The original inventory forms, submitted with the final survey report, are processed separately and stored in the



architectural survey files in the MHT library in notebooks in the MHT library. (See Chapters IV and VIII for guidance on the preparation and accessioning of the Maryland Inventory of Historic Properties Form and supporting graphic materials.)

### *Standards for Illustrations in the Spiral Bound Final Survey Report*

The following elements must characterize all report illustrations (maps, drawings, photographs, etc.), which should be called “figures” and numbered in a single running series. Each figure should be identified with:

- An informative title (including location and orientation of the camera for all landscape photographs) with any necessary citations;
- Scale (or indication that a historic source lacks a scale);
- North arrow and key;
- Clarity of illustrations (i.e., original photographs, halftones, or clear photocopies or scans) is of paramount importance;
- Illustrations must supplement text with useful information that is not easily conveyed in written form.

# VII *Compliance Reports*



The preceding chapters described the standards and guidelines for survey, identification, and documentation of standing cultural resources for survey projects in Maryland. Although the same standards and guidelines apply to compliance documents, these specialized reports also contain additional vital information that assists agency personnel (i.e., at the SHPO, the governmental agency sponsoring an undertaking, and the Federal Advisory Council on Historic Preservation) in making informed decisions regarding the identification and treatment of significant historic resources. The submission of reports that lack key information may cause delays. For this reason, the Trust accepts only complete reports—not management summaries—for review. This chapter reviews the essential components of the compliance report.

With respect to compliance projects, reports are always reviewed in two phases. The first is a complete draft report submitted to the Trust's Office of Preservation Services for review. After review by SHPO staff, the report's author(s) will prepare a final, revised document for submission to the Trust.

Contractors and their clients, or the agencies that employ them, should decide which party will submit the draft and final reports to the Trust's Office of Preservation Services. Draft and final reports should be accompanied by cover letters containing agency names. These steps will help to eliminate confusion and prevent delays. Clear prose and illustrations will also help reviewers to interpret the information in the reports. For questions of style in the presentation of technical material, such as tables, footnotes, and the bibliography, follow the most recent edition of *The Chicago Manual of Style*.

For training in the preparation of compliance documents, historians and architectural historians are encouraged to attend the Federal Advisory Council on Historic Preservation's course, "Introduction to Federal Projects and Historic Preservation Law." On June 17, 1999, revised regulations for the implementation of Section 106 became effective. The Trust strongly recommends agencies, project sponsors, and preservation consultants become familiar with the revised regulations before participating in the historic preservation review process. The study of accepted final versions of recent cultural resource reports in the Trust library is also instructive.

## **Report Format and Content**

All reports submitted to the Trust for review should be spiral bound, using 8½" × 11" acid-free paper, along with an electronic copy on an archival disc. The pages should be typed single-spaced and double-sided. Bulky three-ring binders are not acceptable. Illustrations or maps may be larger in size for clarity, if they can be folded to fit in the bound report as pages or inserts in a pocket. Inventory forms are not bound in the report. These original inventory forms must be submitted in both the draft and final phases of the compliance project. Scanned images or clear, sharp copies of photographs and the map may be submitted with the draft; however, photographs inserted on continuation sheets are required in the

final submittal of the inventory forms. After final review and approval, the inventory forms are processed individually as separate documents (see Chapters IV and VIII for guidance on the preparation and accessioning of the Maryland Inventory of Historic Properties Form).

## *Compliance Report Outline*

### **Title Page**

- Title of report including the name, nature, and location (with county) of the project.
- Clear designation of report's author(s) with complete email and mailing address.
- Clear designation of project's principal investigator(s) with complete email and mailing address.
- Names and complete mailing addresses of the lead government agency and of the government agent (i.e., engineering firm, developer, or project sponsor, if appropriate).
- Date of current version of report (i.e., latest production date).



### **Abstract**

- This is an executive summary—at most one half page long—that covers the purpose of the historic preservation work, nature of the given governmental project, location of the project, findings, and recommendations.

### **Table of Contents**

- Entries for all report chapters and headings/sub-headings with appropriate page numbers.
- A figures list including all types of illustrations (i.e., line drawings, plates) and tables, with page numbers for all figures, and appendices.

### **Introduction**

- Briefly state the purpose of the historic preservation project.
  - Identify the lead governmental agency, or project sponsor, if appropriate.
  - Describe the proposed project with anticipated direct and indirect project impacts.
  - Include information on the agency contract or project numbers/names.
  - Cite the specific law calling for the current historic preservation work.
  - Name any governmental agents directly involved with the historic preservation project.
- Include a copy of a county map with project location and a copy of U.S. Geological Survey 7.5' quadrangle map (1"=24,000') showing the Area of Potential Effects, as defined in 36 CFR § 800.2(c) and determined by the governmental agency.
  - Give the dates when background research and architectural investigations were conducted.
  - Specify the total number of acres examined.
  - Give a brief description of the qualifications of historic preservation personnel involved.
  - Describe the organization of the report.



## **Research Design**

- Give a detailed statement of objectives, including applicability of the work to broader county or regional historic and architectural contexts. If a formal scope of work or proposal was prepared, authors may refer to this document, and include it in an appendix to avoid lengthy repetition.
- Describe the methods and techniques of archival and background research, survey, and analysis.
- Discuss the expected results and the proposed disposition of field records and research information.

## **Historic and Architectural Context**

- Guidelines for organizing a historical overview of the project area:
- Determine the kinds of events, patterns of development, or activities for which properties meet the Maryland and National Register criteria (see the list of areas of significance in Section 8 of the Maryland Inventory of Historic Properties and National Register forms).
- Carefully analyze the survey area to identify themes in the area's history and within the general areas of significance that represent significant patterns of American history, architecture, archeology, engineering, and culture and have made significant contributions to the historical development of the locality, state, or nation.
- Identify the concept, time period, and geographical limits for the historic context(s) based on historical research related to theme(s), area(s) of significance, and geographical area. Base this step on historical documentation of and fieldwork in the survey area.
- Consider stages and patterns of area settlement and development; aesthetic and artistic values embodied in the architecture or art, craftsmanship, construction technology, or the style and work of a master; research values or problems related to the area's prehistory or history; social and physical sciences and humanities; and local cultural interest.

## **Results of Field Investigations**

- Include a statement of field conditions and constraints and a qualitative and quantitative description and analysis of the architectural and historic resources with reference to comparable published studies.
- Include maps depicting locations of identified resources, with Maryland inventory numbers, along with boundaries of the Area of Potential Effect and descriptive illustrations.
- When interpreting field-investigation results, refer to historic contexts and research questions; and
- Address the issue of integrity and/or significance as related to the property's eligibility for the National Register, if possible and appropriate.
- Use official Maryland inventory numbers (i.e., site numbers issued by the Trust's Office of Research, Survey, and Registration) to identify resources in the text and illustrations used in both draft and final reports.

## **Summary and Recommendations**

- Discuss the impact of the governmental undertaking on identified cultural properties when recommended by the SHPO (36 CFR § 800.3).
- Include a summary of results and an evaluation of methods and techniques used.
- Include a statement addressing the survey's level of intensity. If it was an intensive survey, address the eligibility of identified cultural properties for the National Reg-



ister of Historic Places and the Maryland Register of Historic Properties. (Chapter IV and V contain guidance on the application criteria used for compliance evaluation.)

### References Cited

- List all references consulted in the report's preparation according to the latest edition of *The Chicago Manual of Style* format.

### Appendices

- Include relevant project correspondence only.
- The scope of work or proposal, if appropriate.
- The qualifications of principal investigator(s). The maximum resume length should be two (2) pages per individual. Each resume must clearly demonstrate that the person meets National Park Service requirements published in the Code of Federal Regulations (36 CFR Part 61 and discussed in Chapter I).

### Standards for Illustrations

The following elements must characterize all report illustrations (i.e., maps, drawings, photographs, etc.), which are called “figures” and are numbered in a single running series:

- informative title, including location and orientation of the camera for all landscape photographs, with any necessary citations;
- scale, or indication that a historic source lacks a scale;
- north arrow and key;
- clarity (i.e., original photographs, scanned images, halftones, or clear photocopies); and
- utility, which means that illustrations should provide useful information that cannot readily be transmitted in written form.

### Coordinating with the SHPO

To provide adequate time to address all historic preservation concerns and to prevent avoidable delays, agency officials, or their officially designated project sponsor, should consult the SHPO as early in the project planning process as possible—when alternative project locations, configurations, and methods are still available; or when program discussions begin; etc.

An agency official should initiate coordination with the Trust with the submission of a written request for assistance in identifying historic properties. To enable Trust staff to respond in a timely and effective manner, the request should include: 1) a brief description of the proposed undertaking and the nature of federal or state agency involvement; 2) a clear delineation of the project's Area of Potential Effect marked on a section of a U.S. Geological Survey 7.5' quadrangle, or other 1"= 2,000' scale map (see below for clear understanding of the APE); 3) a summary of the agency's review of existing information on known and potential architectural and historic properties, including the Maryland Inventory of Historic Properties and surveys by Certified Local Governments that may be affected by the undertaking; 4) a detailed description of past land use on the subject property; and 5) labeled photographs of known and potential architectural and historic properties.

### Determining the Area of Potential Effect (APE)

The Area of Potential Effect means the geographical area or areas within which an undertaking may directly or indirectly cause changes in the character or use of historic properties, if any such properties exist. The area of potential effect is influenced by the scale and nature of an undertaking and may be different for different kinds of effects caused by the undertaking (36 CFR § 800.16(d)).

The first and most essential step in the compliance review process is determining the Area of Potential Effect using a map (i.e., U.S. Geological Survey 7.5' quadrangle, or other 1" = 2,000' scale map) showing the area and indicating the acreage surveyed for the project. Factors to be considered in preparing an APE are the anticipated impact of the project, the characteristics of resource types expected to be found within the APE, the number and types of alternatives under consideration, and potential geographic and topographic changes.

The Federal Agency determines the Area of Potential Effect. If the Trust staff recommends preparation of a compliance report, the agency should submit a draft of the compliance report (see outline described above). For purposes of clarity, the draft report must include the original photographs or sharp, clear photocopies. The draft report will facilitate the Trust staff's review of potentially significant resources.

After addressing staff review comments and incorporating needed changes and requested revisions, the agency will then submit its final report.

## Identification of Properties

The goal of property identification for compliance projects is to locate architectural and historic properties that may be eligible for the National Register of Historic Places or the Maryland Register of Historic Properties, as appropriate, in an undertaking's Area of Potential Effect. All identification projects should begin with the formulation of an explicit plan or program of architectural and historical study—a research design. The research design for a compliance project describes activities that will accomplish the goals of an identification study (Chapter III includes more comprehensive directions and describes the important components of the research design). Part of the research design might take the form of a proposal written in response to a request for bids.

## Research Design

The Secretary of the Interior's *Standards and Guidelines or Standards for Historic Preservation Projects* requires that a research design for a historic preservation project have three major sections: objectives, methodology, and expected results. The objectives section should begin with a discussion of why architectural and historical identification is necessary. This should include the name of the governmental agencies and other parties involved in the undertaking; the nature of the undertaking (i.e., construction of a transmission line with certain access roads) and its Area of Potential Effect, where both the direct and indirect consequences of a project may occur. This discussion should also cite the specific laws, regulations, guidelines, and other requirements that either call for or apply to the project. Based on this information, project historians or architectural historians will determine the appropriate level of research to be conducted. Specific objectives of a compliance investigation should include:

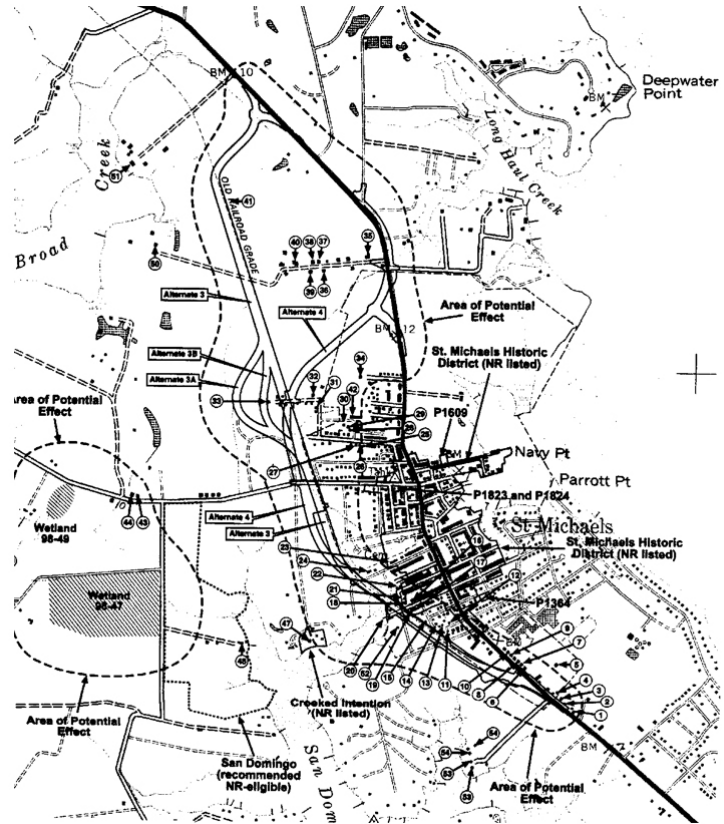

- an inventory of all architectural and historic properties in the APE;
- characterization and interpretation of all identified architectural and historic properties with respect to the historic contexts outlined in the state plan;
- an appraisal of the results of the investigations in light of existing architectural and historic information;
- an evaluation of National or Maryland register eligibility; and
- an assessment of the undertaking's effects on the identified architectural and historic properties.

The methodology section of a research design should describe the amounts and kinds of archival or background research, field investigations, and analytical studies anticipated to achieve the goals and objectives of the project. Descriptions of the general research methods (i.e., literature review, archival and background research, and oral history) and specific survey techniques (i.e. reconnaissance or intensive survey). To ensure a successful outcome of the research, plan appropriate strategies for the particular project area's size, accessibility, environmental characteristics, and expected architectural and historic properties. This explicit discussion of research methods and survey techniques will also help agency reviewers and other architectural historians and historians to judge the quality and effectiveness of the work.

The expected results section of the research design should discuss the number, size, location, age, and characteristics of the architectural and historic resources anticipated in the area of potential effect. Thorough background research into the project area and

the historic contexts for analogous locations can provide the basis for these expectations. Whenever possible, make a preliminary field check to provide familiarity with the APE's potential historic resources and cultural and historic landscape.

Additional technical information for developing strategies for identification surveys can be found in the publications listed in the Secretary of the Interior's *Standards for Identification*. Numerous other sources of information on survey methods and strategies are cited in Chapter 8.

### *Archival and Background Research*

The purpose of archival and background research is to acquire information on a project

area's known and potential architectural and historic properties before initiating time-consuming and costly field investigations. Most archival and background studies should be completed and their results assessed before fieldwork begins so that the preliminary survey strategies outlined in contract proposals may be refined. The non-field research will help guide the field survey by indicating where any documented Maryland Register or National Register eligible architectural and historical sites are located and where other significant properties may be found.

### *Fieldwork*

The Federal Advisory Council on Historic Preservation's regulations for the Section 106 review process state that federal agency officials "shall make a reasonable and good faith effort to carry out appropriate identification efforts. . ." (36 CFR § 800.4(b) (1)). In the same



manner, historians and architectural historians conducting surveys for all federal and state compliance projects in Maryland are to conduct their investigations with “a reasonable and good faith effort.” A reasonable and good faith effort would, in most cases, include well-designed reconnaissance or intensive surveys to collect the necessary representative information in the Area of Potential Effect, and the systematic application of field survey techniques, whatever the level used. Surveys performed according to a judicious survey methodology will help to reduce project costs while yielding credible information on the distribution of historic standing properties throughout a project tract. (See Chapter IV for information on the preparation of the Maryland Inventory of Historic Properties Form and how to determine the appropriate survey treatment for historic standing structures.)

## Evaluation of Properties

The goal of evaluation for compliance projects is to determine if an architectural and historical property identified in a project’s APE is eligible for inclusion in the National Register of Historic Places (for federal projects) or the Maryland Register of Historic Properties (for state projects). To decisively evaluate the eligibility of a cultural resource, the accumulated documentation must demonstrate that the subject property does or does not meet the four eligibility criteria for the Maryland Register of Historic Properties and National Register of Historic Places.<sup>6</sup> These criteria define the scope and nature of historic and archeological properties that are considered for listing in the Maryland Register of Historic Properties and the National Register of Historic Places (see Chapter IV).

When developing a compliance report and documenting individual historic properties or districts, the preparer should focus on three major areas: its significance within local, state, and national contexts; its historical and architectural integrity; and a clear definition of the resource’s boundaries. Care in documenting and identifying the areas of significance and physical characteristics of historic properties are fundamental to subsequent assessments of project effects and may suggest appropriate treatment measures.

In most cases, the significance of any one resource cannot be fully evaluated until the survey area’s historic contexts have been developed and other resources in the project area have received some reasonably comparable level of documentation. During the survey, the investigator should record the qualities of each property that relate it to the project area’s historic contexts and may contribute to its significance. (See below.) The surveyor should also note any qualities that appear unique or significant and should record these observations for future reference and evaluation. Evaluation of a property is based upon relevant historic contexts and the areas of significance under which the property may be important, for example agriculture or architecture. (See Chapter IV and V for more on the areas of significance used by the Maryland and National register programs.) The areas in which a property may be significant should be recorded on the *Maryland Inventory of Historic Properties Form* or *National Register of Historic Places Form* and supported in the statement of significance.

Whether showing that a property is or is not significant, the statement of significance should be developed as a well-reasoned argument that identifies the historic context or contexts to which the property relates and discusses the property type within relevant historic contexts and describes the characteristics that justify its place within the context.

The exact information needed to evaluate significance depends upon a property’s historic context. In most cases, the needed information will fall into one or more context categories, which include

---

6. Described in Chapter IV and cited in Maryland Department of Housing and Community Development Title 05.08.05 and 36 CFR Part 60.4.



- historically significant events/or patterns of activity associated with the property;
- significant period or periods of time during which the property was in use;
- specific dates or period(s) of time when the resource achieved its importance (i.e. date of construction, date of a specific event, period of association with an important person, period of an important activity);
- historically significant persons associated with the property (i.e. tenants, visitors, and owners);
- exemplification of a style, period, or method of construction;
- person(s) responsible for its design or construction;
  - quality of style, design, or workmanship;
  - historically or culturally significant group associated with the property and the nature of the association;
  - information that the property may yield (especially true of archeological sites and districts).



A property's integrity enables it to clearly convey its historic identity and significance. Therefore, a description of the physical characteristics of a historic resource is an important consideration in its evaluation. The survey should produce sufficient information for an authoritative description of the property's physical appearance and condition. In most cases, a description following the guidelines presented in Chapter IV will be sufficient. However, if a building is judged to be ineligible based on its lack of structural integrity, a structural engineer's report may be required to substantiate the recommendation. Guidelines for evaluating the significance and integrity of historic properties are contained in *National Register Bulletin 15:*

*How to Apply the National Register Criteria for Evaluation.*

A final important component of the review of a historic property is a definition of its boundaries, which may be either spatial or conceptual, or both. The acreage of the property, a written description of its boundaries, and a statement justifying the choice of particular boundaries are vital to an understanding of the nature and extent of a historic resource. Carefully defined boundaries are important to individual properties as well as historic districts and may require considerable professional judgment. (See *National Register Bulletin 21: How To Establish Boundaries for Historic Properties* for technical information on this subject.) Documentation for complexes containing more than one building, structure, or object, or for historic districts must contain a statement clearly categorizing all inventoried properties as contributing or non-contributing (see Chapter IV for guidelines for counting resources). Factors that influence the selection of boundaries include the distribution of significant features, uses, historic associations, property lines, integrity of the site, topographic features, and visual qualities, both natural and historic.

## Assessing Effects

If a survey reveals historic properties listed in, or determined eligible for, inclusion in the Maryland Register of Historic Properties or National Register of Historic Places, the agency must assess how its project will affect them. Throughout this assessment stage, the agency should work with the Trust staff and consider the views of others, such as representatives of local governments, property owners, members of the public, and the Advisory Council on Historic Preservation. The agency's assessment must be based on a complete documentation of the significant characteristics of any eligible or potentially eligible historic standing structures within the area in question and the project's potential impact on them. This



documentation can be presented as part of the compliance report, or may be contained in a letter from the agency to the Trust. In either instance the statement must be well justified. In making its assessment, the agency should use the criteria found in the Advisory Council's regulations (36 CFR § 800.5).

Upon completion of its deliberations, the agency can make one of three determinations:

- no effect—the undertaking will not affect historic properties;
- no adverse effect—the undertaking will affect one or more historic properties, but the effect will not be harmful—or
- adverse effect—the undertaking will harm one or more properties.

If an adverse effect will occur, the agency should consult with the Trust staff and others (i.e., local governments, property owners, members of the public, and the Federal Advisory Council on Historic Preservation) to find ways to reduce, avoid, or mitigate the adverse effect. A productive consultation will result in a Memorandum of Agreement (MOA) outlining the measures the agency agrees to take to account for the adverse effects on historic properties. In rare situations when consultation is unproductive, the agency, the Trust, or the Advisory Council may terminate consultation. Should that occur, the agency would be required to submit appropriate documentation to the Advisory Council for its written comment. In limited cases, the Advisory Council may comment during the consultation step by participating in and signing the MOA.

If a MOA is executed, the agency must submit a copy of the MOA with supporting documentation noted in 36 CFR § 800.11(F) to the Advisory Council before approving the undertaking. The agency proceeds with its undertaking under the terms of the MOA. In the absence of an accepted MOA, the agency head must take into account the Advisory Council's written comments in deciding whether and how to proceed.

## Treatment

Treatment measures may be agreed upon to mitigate or take into account any adverse effects of the proposed undertaking. In some situations, historic properties cannot be saved and consequently should be fully documented before destruction. More commonly, the goal is to protect the historic properties. Protection is a broad term referring to the process of determining and implementing the steps that must be taken to preserve and enhance those historic properties considered important.

When historical property protection relates to environmental review and compliance procedures, it has two aspects: integration into land use planning and zoning processes (at the local level) and physical treatment. The planning aspects of protection in environmental review have been discussed briefly in previous sections. Treatment concerns the historic materials in buildings, structures, sites, and objects listed in the National Register of Historic Places and Maryland Register of Historic Properties.

The Secretary of the Interior's *Standards for the Treatment of Historic Preservation Projects* (36 CFR Part 68) defines appropriate treatments for historic properties in roughly a hierarchical order, determined by the amount of intervention into the building's materials and form. This hierarchy includes protection, which



is a temporary act or process of applying measures to defend or guard a historic property from deterioration, loss or attack; stabilization, which refers to measures taken to reestablish a weather resistant enclosure or the structural stability of an unsafe or deteriorated property; preservation, which refers to measures taken to sustain the existing form, integrity, and material of a building or structure; rehabilitation to return a property to a state of utility through repair or alteration; and restoration, which involves an accurate recovery of the form and details of a property and its setting as it appeared in a particular period of time.

Treatment measures may also be negotiated that include public interpretation or architectural salvage, moving a building, landscaping, design review of new additions/new construction, interim protection of property, and data recovery or recordation. One of the principal forms of recordation used in Maryland is the Maryland Inventory of Historic Properties Form (see Chapter IV). In some cases, historic properties may require other documentation, such as the National Register Form for which forms and guidance materials are available at the Trust's Office of Research, Survey, and Registration; and/or delineation according to the Historic American Buildings Survey (HABS); or the Historic American Engineering Record (HAER) standards (i.e., the Secretary of the Interior's *Standards and Guidelines for Architectural and Engineering Documentation: HABS/HAER Standards* (1990) available from the National Park Service).

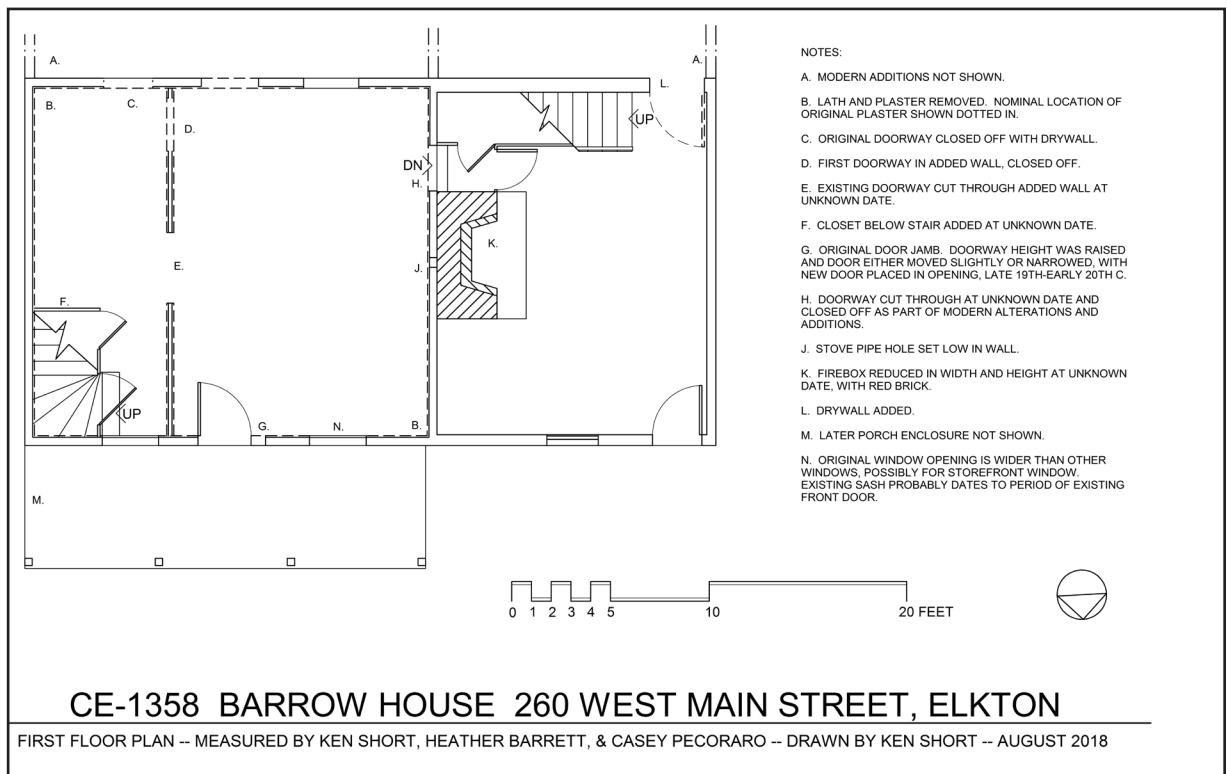

# VIII *Accessioning Procedures*



**W**ritten and graphic documentation for historic resources in Maryland is generated by an array of programs within the Trust. Materials may be submitted in a variety of forms, including the Maryland Inventory of Historic Properties forms, final survey reports, compliance reports, documentation for the Historic American Building Survey/Historic American Engineering Record (HABS/HAER), and measured drawings. After review and approval by the Trust staff, these various survey and research products are accessioned into the Archives and Library of the Trust. This is the state's principal repository for information about Maryland's architectural, archeological, and cultural resources. The holdings of the library include the following:

- Inventory forms for standing structures and site files for archeological sites
- National Register nomination forms
- Map collection (archeological and architectural site locations and historical maps and atlases)
- Photographs and negatives (architectural resources)
- Slides (archeological and architectural sites and preservation-related activities)
- Digital image files (TIF format) on archival disks
- Books
- Professional journals and newsletters
- Architectural drawings
- Historic Structure Reports
- Plans (development plans, town plan, etc.)
- Compliance (archeological and architectural) site and survey reports
- Vertical files (correspondence, news clippings, brochures, and pamphlets)
- Microform
- Folklife documentation
- Audio and video cassettes
- Archeological Society of Maryland, Inc. Library

The Maryland Historical Trust maintains Medusa, the State of Maryland's Cultural Resource Information System. Through Medusa, qualified resource professionals are able to access information about resources recorded in the Maryland Inventory of Historic Properties (MIHP) and the National Register of Historic Places (NRHP), as well as properties on which MHT holds preservation easements and information on resources that have been evaluated for National Register eligibility (Determinations of Eligibility, or DOEs). The system allows access to archeological records to qualified researchers with a valid Medusa account, including professional archeologists, agency representatives, and researchers working directly with professional archeologists.

The library is open to the public on Tuesdays, Wednesdays, and Thursdays by appointment only. All material related to Maryland's archeological sites is accessible only to qualified researchers who have applied for, been approved, and received a password for a Me-



dusa account. To request an account, go to <https://apps.mht.maryland.gov/medusa/RequestUserAccount.aspx>. Researchers needing access to material related to archeological sites must be approved for an account before calling to make an appointment. For further information, contact the librarian at (410) 697-9546.

## Maryland Inventory of Historic Properties Form

After review and approval by qualified architectural historians on the MHT staff, the Maryland Inventory of Historic Properties (MIHP) form becomes the centerpiece of the survey data files. Certified Local Government materials are reviewed by the Administrator, State-wide Preservation Programs. Compliance-generated forms are reviewed by the Office of Preservation Services, Review and Compliance unit. The Architectural Survey Administrator reviews all other inventory forms. The Trust has established guidelines for the submission of documentation related to architectural investigations as follows:

Regardless of the level of survey, all forms (hard copy and electronic) must be submitted with the required supplementary materials, including capsule summaries, photographs,



digital image files on archival disks, drawings (if applicable), and the USGS topographic quadrangle maps.

The Inventory Registrar will process all forms and accompanying documentation after it has been reviewed and approved by Trust staff. All properties are required to be identified by an inventory number assigned by the Inventory Registrar. The inventory number should always be formatted exactly as issued by the Inventory Registrar and is not transferrable to another property. Usually this assignment of inventory numbers is requested during an early phase of a survey or compliance project. If an inventory number has not been assigned, the Inventory

Registrar will return all materials to the consultant with a designated number to be labeled on all materials.

After approval by MHT staff, the MIHP form(s) are processed and accessioned into the architectural survey files within the library and archives. The electronic forms are uploaded into Medusa, where they are available in PDF format, while the hard copies are filed in the library. The documentation status in Medusa will be updated from “No Documentation on File” to “On File” at this time. The MIHP form(s) and accompanying documentation for all surveys should be organized by Maryland inventory number to facilitate processing. The contents are checked to ensure that all the required materials have been submitted (see Chapter IV: Submittal of Documentation). If any of the required materials are missing, or not in adherence with Chapter IV, MHT staff will convey this to and coordinate with the preparer on any necessary corrections.

During processing and accessioning of the forms, Trust staff use the USGS quad maps that are submitted with the completed forms to map the final survey area boundary into the appropriate GIS layer in Medusa. Available layers include not only the MIHP, but also National Register properties, “short DOE” (determination of NR eligibility) records, and locations of sites in the MHT Easement program. A “Pending Submittals” layer is also available to indicate the location of properties which have been assigned inventory numbers, but for which the survey documentation has not yet been completed and submitted to MHT.

## Compliance Reports

Compliance reports are prepared in draft and final stages. After review by MHT staff, comments on the draft reports are sent to the submitting agency and consultant. The report is then submitted to the Librarian for processing and accessioning. After final reports are received and approved, they supersede the draft reports in the library collection. The MIHP forms generated by a compliance project are processed as described above and must meet the same organizational and packaging requirements.

## Final Survey Reports

Final survey reports are submitted to the Architectural Survey Administrator just before completion of grant-funded projects. Following approval and acceptance of all final products as described in the grant contract, the final survey report is submitted to the librarian for processing. After being accessioned, the bound reports with their original and final research designs are entered into the Field and Research Reports (FRR) section of the library.

## Historic American Buildings Survey (HABS) and Historic American Engineering Record (HAER) Materials

Documentation to HABS/HAER standards is submitted to appropriate staff for review. If not forwarded to the National Park Service, all materials are given to the Librarian to be logged in and accessioned. Written reports become a part of the library collection. Photographs are placed in inert archival sleeves and entered in the photograph collection. Drawings are processed and become part of the architectural drawing collection. If appropriate, early drawings, such as designs or “as-builts,” may be given to the Maryland State Archives. Please refer to the HABS/HAER guidelines for current guidance for completing this type of document.







# ***IX Survey and Planning Materials***



## **Technical Information**

### **Advisory Council on Historic Preservation:**

- 1985 *Protection of Historic Properties, 36 CFR Part 800.*
- 1986 *Section 106, Step-by-Step.*
- 1988 *Identification of Historic Properties: A Decision-making Guide for Managers.*
- 1989 *Public Participation in Section 106 Review: A Guide for Agency Officials.*

### **Advisory Council on Historic Preservation and National Park Service:**

- 1989 *Preparing Agreement Documents: How to Write Determinations of No Adverse Effect, Memoranda of Agreement, and Programmatic Agreements Under 36 CFR Part 800. ACHP, Washington, D.C.*
- 1989 *The Section 110 Guidelines: Annotated Guidelines for Federal Agency Responsibilities under Section 110 of the National Historic Preservation Act. ACHP and NPS, Washington, D.C.*

Advisory Council publications, fact sheets, and information about their training courses are available at <https://www.achp.gov>.

### **National Park Service:**

- 1981 36 CFR 60: National Register of Historic Places.
- 2003 Secretary of the Interior's Standards and Guidelines for Architectural and Engineering Documentation: HABS/HAER Standards.

Additional materials regarding the Secretary of the Interior's Standards and Guidelines for Archeology and Historic Preservation are available at [https://www.nps.gov/history/local-law/arch\\_stnds\\_0.htm](https://www.nps.gov/history/local-law/arch_stnds_0.htm) and for HABS/HAER at <https://www.nps.gov/hdp/>.

### **National Register of Historic Places Bulletin Series:**

- How to Apply the National Register Criteria for Evaluation (#15)*
- How to Complete the National Register Registration Form (#16A)*
- How to Complete the National Register Multiple Property Documentation Form (#16B)*
- How To Evaluate and Nominate Designed Historic Landscapes (#18)*
- Nominating Historic Vessels and Shipwrecks to the National Register of Historic Places (#20)*
- Defining Boundaries for National Register Properties (#21)*
- Guidelines for Evaluating and Nominating Properties That Have Achieved Significance Within the Past Fifty Years (#22)*

*How to Improve the Quality of Photographs for National Register Nominations (#23)*  
*Guidelines for Local Surveys: A Basis for Preservation Planning (#24)*  
*Using the UTM Grid System to Record Historic Sites (#28)*  
*Guidelines for Evaluating and Documenting Rural Historic Landscapes (#30)*  
*Guidelines for Evaluating and Documenting Properties Associated with Significant Persons (#32)*  
*Guidelines for Evaluating and Documenting Traditional Cultural Properties (#38)*  
*Researching a Historic Property (#39)*  
*Guidelines for Evaluating and Registering Cemeteries and Burial Places (#41)*  
*Guidelines for Identifying, Evaluating, and Registering Historic Mining Properties (#42)*  
The National Register Bulletin Series may be downloaded from: <https://www.nps.gov/subjects/nationalregister/publications.htm>

## Survey Publications

Blumgart, Pamela James, et al., *At the Head of the Bay: A Cultural and Architectural History of Cecil County, Maryland*, Elkton: Cecil Historical Trust, and Crownsville: Maryland Historical Trust, 1996.

Bourne, Michael, *Historic Houses of Kent County: An Architectural History 1642-1860*, Chestertown: The Historical Society of Kent County, 1998.

Bourne, Michael, *Inventory of Historic Sites in Caroline County*, Annapolis: Maryland Historical Trust, 1980.

Bourne, Michael, et al. *Architecture and Change in the Chesapeake: A Field Tour on the Eastern and Western Shores*, Crownsville: Maryland Historical Trust Press, 1998.

Getty, Joe, *Carroll's Heritage: Essays on the Architecture of a Piedmont Maryland County*, Westminster, Md.: Carroll County Commissioners and Historical Society of Carroll County, 1987.

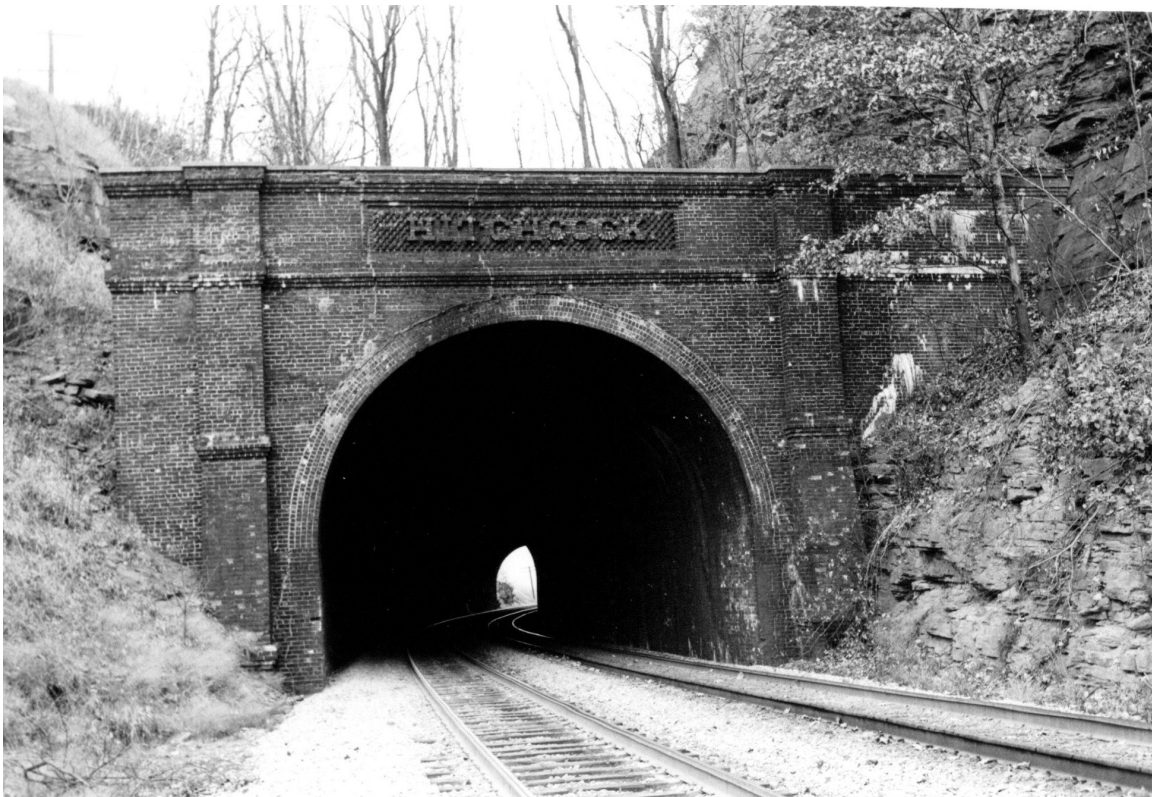

- Hughes, Elizabeth, *Historic St. Michaels: An Architectural History*, Chestertown, Md.: River Press, 1996.
- Inventory of Historic Sites in Calvert County, Charles County and St. Mary's County*, Annapolis: Maryland Historical Trust, 1980.
- Kelly, Clare Lise, *Montgomery Modern: Modern Architecture in Montgomery County, Maryland, 1930-1979*, Silver Spring: M-NCPPC, 2015.
- Larew, Marilyn M., *Bel Air: An Architectural and Cultural History, 1782-1945*, Bel Air: Town of Bel Air and Crownsville: Maryland Historical Trust, 1995.
- Maryland National Capital Park and Planning Commission, *Landmarks of Prince George's County*, Baltimore: The Johns Hopkins University Press, 1993.
- Miller, Marcia and Ridout, Orlando, eds. *Architecture in Annapolis: A Field Guide*, Crownsville: Maryland Historical Trust Press, 1998.
- Ranzetta, Kirk E. *I'm Going Down County: An Architectural Journey Through St. Mary's County*, Annapolis: Maryland Historical Trust, 2010.
- Reed, Paula S., *Tillers of the Soil: A History of Agriculture in Mid-Maryland*, Frederick: Catocin Center for Regional Studies, 2011.
- Robb, Frances C., Teresa S. Moyer, Paula S. Reed, and Edith B. Wallace, *Millers and Mechanics: A History of Industry in Mid-Maryland*, Frederick, Maryland: Catocin Center for Regional Studies, 2011.
- Touart, Paul Baker, *Along the Seaboard Side: The Architectural History of Worcester County, Maryland*, Snow Hill, Md.: Worcester County Commissioners, 1994.
- \_\_\_\_\_, *At the Crossroads: The Architectural History of Wicomico County, Maryland*, Annapolis: Maryland Historical Trust, 2008.
- \_\_\_\_\_, *Somerset: An Architectural History*, Annapolis: Maryland Historical Trust, 1990.
- Vernacular Architecture Forum, *A Shared Heritage: Urban and Rural Experience on the Banks of the Potomac*, Crownsville: Maryland Historical Trust, 2018.
- Wallace, Kim E., Teresa S. Moyer, Paula S. Reed, and Edith B. Wallace, *Routes of Change: A History of Transportation in Mid-Maryland*, Frederick, Maryland: Catocin Center of Regional Studies, 2011.
- Ware, Donna M., *Anne Arundel's Legacy: The Historic Properties of Anne Arundel County*, Annapolis: Maryland Historical Trust, 1990.
- \_\_\_\_\_, *Green Glades & Sooty Gob Piles: The Maryland Coal Region's Industrial & Architectural Past*, Annapolis: Maryland Historical Trust, 1991.
- Weeks, Christopher, *An Architectural History of Harford County, Maryland*, Baltimore: Johns Hopkins University Press, 1996.
- \_\_\_\_\_, ed., *Between the Nanticoke and the Choptank: An Architectural History of Dorchester County, Maryland*, Baltimore: Johns Hopkins University Press, 1984.
- \_\_\_\_\_, et. al., *Where Land and Water Intertwine: An Architectural History of Talbot County, Maryland*, Baltimore: Johns Hopkins University Press, 1984.
- Williams, Kimberly Prothro and Elizabeth Jo Lampl, *Chevy Chase: A Home Suburb for the Nation's Capital*, Annapolis: Maryland Historical Trust, 1998.

## General Reference

- Blumenson, John J.-G., *Identifying American Architecture*, rev. ed., Nashville, Tennessee: American Association for State and Local History, 1981.
- Burns, John A., ed., *Recording Historic Structures* (Second Edition), Hoboken, New Jersey: John Wiley & Sons, 2004.
- Carson, Cary and Carl Lounsbury, eds. *The Chesapeake House: Architectural Investigation by Colonial Williamsburg*, Chapel Hill: Published in association with the Colonial Williamsburg Foundation by the University of North Carolina Press, 2013.
- Federal Historic Preservation Laws*. Washington, D.C., 1993.

- Glassie, Henry, *Pattern in the Material Folk Culture of the Eastern United States*, Philadelphia: University of Pennsylvania Press, 1968.
- Lanier, Gabriele and Bernard Herman. *Everyday Architecture of the Mid-Atlantic*, Baltimore: Johns Hopkins, 1997.
- Lounsbury, Carl R., ed., *An Illustrated Glossary of Early Southern Architecture and Landscape*, New York and Oxford: Oxford University Press, 1994.
- McAlester, Virginia and Lee, *A Field Guide to American Houses (Revised): The Definitive Guide to Identifying and Understanding America's Domestic Architecture*, New York, Alfred Knopf, 2015.
- Poppeliers, John, S. Allen Chambers, and Nancy B. Schwartz, *What Style Is It?* rev. ed., Washington: Preservation Press, 1983.
- Saylor, Henry H., *Dictionary of Architecture*. New York: John Wiley & Sons, 1952.
- Whiffen, Marcus, *American Architecture Since 1780: A Guide to the Styles*. Cambridge, Massachusetts: MIT, 1969.

## Selected Internet Resources

- Advisory Council on Historical Preservation*: <https://www.achp.gov/>
- HABS/HAER*: <https://www.nps.gov/hdp/>
- Library of Congress*: <https://www.loc.gov>
- Maryland Association of Historic District Commissions*: <https://mahdc.org/>
- Maryland Historical Trust*: <https://mht.maryland.gov/>
- Maryland State Archives*: <http://www.mdarchives.state.md.us>
- Maryland Historical Society*: <https://www.mdhs.org/>
- National Archives and Records Administration*: <https://www.nara.gov/>
- National Conference of State Historic Preservation Officers*: <http://ncshpo.org/>
- National Park Service*: <https://www.nps.gov>
- National Register of Historic Places*: <https://www.nps.gov/subjects/nationalregister/index.htm>
- National Register of Historic Places Program, Historic Preservation Links*: [https://www.nps.gov/NR/preservation\\_links.htm](https://www.nps.gov/NR/preservation_links.htm)
- National Center for Preservation Technology and Training*: <https://www.ncptt.nps.gov>
- National Trust for Historic Preservation*: <https://savingplaces.org/>
- Vernacular Architecture Forum*: <http://www.vernaculararchitectureforum.org/>



# Appendix A

## Photo Continuation Sheet

**Maryland Historical Trust  
Maryland Inventory of  
Historic Properties Form**

Inventory No: PG:81A-1

Name: Poplar Hill at His Lordship's Kindness  
Continuation Sheet

Number      Photos      Page 1



Photo 1 of 10: Front Façade, camera facing southeast.



Photo 2 of 10: Pigeon Cote and Peafowl Pen, camera facing west.

**Maryland Historical Trust  
Maryland Inventory of  
Historic Properties Form**

Inventory No: PG:81A-1

Name: Poplar Hill at His Lordship's Kindness  
Continuation Sheet

Number Photos Page 2

---

**PHOTO LOG**

**Name of Photographer: Heather Barrett**  
**Date of Photograph: May 5, 2018**  
**Location of Original Digital File: MD SHPO**

*Photographs inserted on continuation sheets.*

**Photo 1 of 30:**  
**Front Façade, camera facing southeast.**  
**[PG;81A-1 2018-5-5 01.tif](#)**

**Photo 2 of 30:**  
**Pigeon Cote and Peafowl Pen, camera facing west.**  
**[PG;81A-1 2018-5-5 02.tif](#)**

**Photo 3 of 30:**  
**ETC.**

*Additional digital image files are located at the Maryland Historical Trust.*

**Photo 21 of 30:**  
**Stair Detail, camera facing southeast.**  
**[PG;81A-1 2018-5-5 21.tif](#)**

**Photo 22 of 30:**  
**ETC.**

NOTE: Per the *Standards & Guidelines*, the preparer may submit up to 20 images in print form or on continuation sheets. Printed photographs must accompany all grant-funded and National Register nomination projects. If you elect to provide more than 20 images, please include them as digital files only on archival CDs. Each photo log should clearly indicate for which photo numbers there are hard copy prints or images on continuation sheets, and for which photo numbers there are additional digital images available on CD only.

# ***Appendix B Standards for Submission of Digital Images to the Maryland Inventory of Historic Properties***

Effective January 2008  
Revised February 2019

The Maryland Historical Trust will accept submissions of digital images for inclusion in the Maryland Inventory of Historic Properties. All grant-funded projects must submit printed photographs.

Traditionally processed black-and-white photographs, as laid out in the *Standards and Guidelines for Architectural and Historical Investigations in Maryland*, are still preferred. **Please note that such traditionally-processed, black-and-white photographs do not refer to negatives processed with the Process C-41 color chemistry used at most commercial and “custom” labs or to photographs printed on chromogenic papers available (see below).**

As of the above revised date, images produced from digital media may be submitted, as long as they meet the following standards:

## **General Requirements**

Documentation using digital media will include:

- 5 × 7 black-and-white or color prints produced using ink and paper combinations giving a minimum 75-year archival standard (see below) and labeled to MHT standards.
- Digital files in an uncompressed TIF format, properly named, labeled and burned onto a 75-year, “gold”-type archival CD or DVD (see below).
- A photo log.

## **Photographic Print Requirements**

- 1 All prints will be 5 × 7, printed in black and white or color.
- 2 Prints produced from digital images must meet a 75-year archival standard. The Maryland Historical Trust does not endorse any particular commercial product or process, but follows the recommendation for permanence established by the National Register of Historic Places. A non-comprehensive list of photographic ink and paper combinations that have been demonstrated to meet the 75-year permanence standard may be found below for guidance in meeting the 75-year standard.

The non-comprehensive list below includes products that meet the MHT permanence standard. Specific printers are not identified, as the longevity of a print is dependent on the ink and paper combinations used to produce it, rather than on the printer.

<b>Printer Inks</b>	<b>to be used with</b>	<b>Papers</b>
<b>Epson UltraChrome pigmented inks</b>		Epson Premium Glossy Paper Epson Premium Semigloss Photo Paper Epson Premium Luster Photo Paper Epson Premium Semi-Matte Photo Paper Epson UltraSmooth Fine Art Paper Somerset Velvet for Epson Epson Velvet Fine Art Paper Epson Enhanced Matte Paper
<b>Epson PictureMate Inks</b>		Epson PictureMate Photo Papers
<b>Hewlett-Packard (HP) 84/85 dye-based inkset</b>		HP Premium Plus Photo Paper HP Premium Plus Photo Paper, High Gloss or Glossy
<b>HP Vivera inks (95 and 97 tri-color cartridges)</b>		HP Premium Plus and HP Premium Photo Papers (high gloss, glossy, and soft gloss)
<b>Canon ChromaLife 100+ CLI-251</b>		HP Advanced Photo Paper, Glossy

More information on the archival properties of inks and digital papers can be found at:  
**<http://www.wilhelm-research.com>**

## **File Requirements**

All prints produced from digital photographs and submitted to the MIHP, must be accompanied by corresponding electronic image files.

- be first generation
- be original capture .tif or tiff (Tagged Image File format) files or raw files converted to .tiff, and labeled according to the requirements below,
- have a pixel array of at least 3000 x 2000,
- have a resolution of 300 ppi (pixels per inch) or larger,
- be saved RGB color mode, which provides maximum detail even when printed in black-and-white,
- be submitted on CD-R or DVD-R gold disks labeled in permanent archival ink (not a Sharpie) with the MIHP number and date.

Make sure to close and finalize the CD or DVD.

## **File Naming**

The file naming system for electronic images is based on the Maryland Inventory of Historic Properties number. The MIHP numbering convention is generally consistent throughout the state but slight variations by county do exist and therefore the digital naming system will do likewise. The basic naming structure for digital image files consists of three elements, separated by underscores: 1) the MIHP number (county code- four digit number); 2) the eight digit numerical date of creation (yyyy-mm-dd); 3) a two digit photo number. Thus digital image files of the Maryland State House (MIHP number AA-685) taken on June 3, 2007 would be named AA-0685\_2007-06-03\_01.tif; AA-0685\_2007-06-03\_02, etc. County variations are as follows:



**Allegany County:** Allegany County MIHP numbers contain district numbers (I-VII) and letters. Digital images for MIHP number AL-V-A-47 and shot on June 7, 2007 would be labeled:

AL-V-A-0047\_2007-07-03\_01.tif, AL-V-A-0047\_2007-07-03\_02.tif, etc.

**Frederick County:** Frederick County MIHP numbers contain district numbers (1-8). Digital images for MIHP number F-7-326 and shot on November 3, 2007 would be labeled:

F-7-0326\_2007-11-03\_01.tif, F-7-0326\_2007-11-03\_02.tif etc.

Frederick Historic District MIHP numbers use the code FHD followed by a four digit number: FHD- 1234\_2007-11-03\_01.tif, etc.

**Garrett County:** Garrett County MIHP numbers contain district numbers (I-VI) and letters. Digital images for MIHP number G-V-A-261 and shot on March 13, 2007 would be labeled:

G-V-A-0261\_2007-03-13\_01.tif, G-V-A-0261\_2007-03-13\_02.tif, etc.

**Montgomery County:** Montgomery County MIHP numbers include a colon after the county code, followed by a space and a regional number (1-37), follow by a dash and a site number. **In digital file names, the colon is replaced by a semi-colon and the space remains.** Digital images for MIHP number M: 37-44 and shot on August 5, 2007 would be labeled:

M; 33-44\_2007-08-05\_01.tif, M; 37-44\_2007-08-05\_02.tif, etc.

Some Montgomery County MIHP numbers have site sub-numbers: M: 37-44-01. These sub-number are indicated after a dash: M; 37-44-01\_2007-08-05\_01.tif

**Prince George's County:** Prince George's County MIHP numbers include a colon after the county code followed by a regional number (61-87), a dash and a site number. **In digital file names, the colon is replaced by a semi-colon.** Digital images for MIHP number PG:60-25 and shot on January 20, 2007 would be labeled:

PG;60-25\_2007-01-20\_01.tifPG;60-25\_2007-01-20\_02.tif, etc.

Laurel Historic District MIHP numbers use the code LAU- in between the semi-colon and the site number (there are no district numbers):

PG;LAU-12\_2007-01-20\_01.tif, etc.

**Washington County:** Washington County MIHP numbers contain district numbers (I-IV). Digital images for MIHP number WA-II-313 and shot on October 31, 2007 would be labeled:

WA-II-0313\_2007-10-31\_01.tif, WA-II-0313\_2007-10-31\_02.tif etc.

Resources in town historic districts in Washington County insert a town code (with dashes) between the county code and site number: Hagerstown: WA-HAG-001\_2007-01-01\_01.tif, etc; Hancock: WA-HAN- 001\_2007-01-01\_01.tif, etc.; WilliamSPORT: WA-WIL-001\_2007-01-01\_01.tif, etc.

## Additional Requirements

- All printed digital photos will be labeled on the back of the image in soft pencil or archival ink as required in *Standards and Guidelines for Architectural and Historical Investigations in Maryland*, p. 39-40.
- A photo log in Microsoft Word must be included with the Maryland Inventory of Historic Properties form. Each log should include the exact image file name and a description of the view. The log will note the ink and paper combination used to create the photos.

Please contact the MHT staff person you are working with for more information.

For more information, please contact:

Heather Barrett, Administrator, Research and Survey Unit,

Phone: 410-697-9536

Maryland Historical Trust

100 Community Place, 3rd Floor,

Crownsville, MD 21032

Email: [heather.barrett@maryland.gov](mailto:heather.barrett@maryland.gov)

# Appendix C

## Submission Checklist

To facilitate the review process and subsequent accessioning of Determination of Eligibility (DOE) and Maryland Inventory of Historic Properties (MIHP) forms into the Maryland Historical Trust Library, please check that the following requirements have been completed prior to the submittal of the hard-copy documentation (and accompanying digital files) for review by MHT staff. All page numbers refer to the Standards and Guidelines for Architectural and Historical Investigations in Maryland, as revised in 2019.

### DOE/MIHP Forms:

- All forms and accompanying documentation must be three-hole punched (p. 37).
- The inventory number as issued by MHT must be included in the appropriate space at the top of each page of the form and on all continuation sheets, maps, drawings, photographs, and the capsule summary (p. 19).
- All sections of the MIHP form, and a capsule summary, must be completed (p. 19).
- If using Continuation Sheets, fill in the inventory number, name of property, and the number of the section being continued. The inventory number and property name should be consistent with the associated property record in Medusa. If in doubt, contact the Inventory Registrar to verify the correct inventory number or property name.
- **Section 1: Name of Property** and **Section 2: Location** should correspond with the information submitted to the Inventory Registrar at the time the number was assigned. If the name or address has changed, please notify the Inventory Registrar.
- **Section 6: Classification** includes the Resource Count. For detailed instructions on how to complete this item, refer to page 23.
- **Section 10: Geographical Data** includes Acreage of Surveyed Property. For detailed instructions on how to complete this item, refer to page 32. The Acreage of Surveyed Property section must be completed in order for MHT to fulfill state and federal reporting duties.

### Accompanying Documentation:

- Each MIHP form must be accompanied by a capsule summary for inclusion with the inventory form (p. 33).
- Two maps (8½ × 11 inches) created using the appropriate section of the USGS topographical quad map, properly labeled, and clearly illustrating the location and boundaries of the resource are required, one at 1:24,000-scale and one at a zoomed-in view such as 1:12,000. For urban properties, a current tax, block and parcel map should be included along with the two USGS quad maps (p. 36).
- Aerial imagery may be submitted in addition to, but not in substitution for, the two USGS quad maps.
- MIHP forms prepared for MHT grant-funded survey projects require 5 × 7 inch printed black-and-white or color photographs, properly labeled and submitted in side-loading archival storage pages (two/page) as specified on page 34.

For more information, please contact:

Mary Kate Mansius, Architectural Registrar, Maryland Historical Trust  
100 Community Place, 3rd Floor, Crownsville, MD 21032  
mary.mansius@maryland.gov  
410-697-9570





# Photo Credits

- Cover, top left: Beatty-Cramer House, Frederick County. David L. Ames, 1992.
- Cover, top right: Poplar Hill on His Lordship's Kindness, Prince George's County, William Graham, 2019.
- Cover, bottom: Mt. Lubentia Dairy, Prince George's County, photographed by William Graham.
- Page i: Brice House, Anne Arundel County. Jeff Klee, 2009.
- Page v: Map of Maryland.
- Page 1: Briscoe Barn 'F', Calvert County. Tora Williamson, 1990.
- Page 2: Field recording at the Whaley House, Worcester County. Unknown photographer, 1984.
- Page 3: Spano Family House, Howard County. Ken Short and Fred Dorsey, 2016.
- Page 4: 612-614 South Wolfe Street, Baltimore. Bill Lebovich, 2014.
- Page 5: Sotterley, smokehouse, St. Mary's County. Willie Graham, 2019.
- Page 5: Status of Surveyed Structures by County, 2019.
- Page 6: Tulip Hill, Anne Arundel County. Thomas Reinhart, 2010.
- Page 7: U.S. Coast Guard Yard, Curtis Bay. c. 1960.
- Page 8: 117-119 Diamond Alley, Baltimore. Orlando Ridout V, 1979.
- Page 9: Footer's Dye Works, Allegany County. Unknown photographer, 2014.
- Page 10: 412 W. Baltimore Street, Baltimore. Aaron M. Levin, 1989.
- Page 11: Woodfield Fish & Oyster Company Housing, Galesville, Anne Arundel County. Heather Barrett, 2018.
- Page 12: Finney Houses Historic District, Resource Sketch Map, Harford County. Ron Andrews, 1989.
- Page 17: Newtown Manor, St. Mary's County, c. 1955. Image shows Clem Delahay, the last farm manager of Newtown Manor. Courtesy of George Matisick.
- Page 18: Ogle Hall, Annapolis. Willie Graham, 1997.
- Page 19: John Ridout House, Annapolis. Orlando Ridout V, 1997.
- Page 20: Odd Fellows Lodge, Unionville. Paul Touart, 1990.
- Page 21: Hall of Records, Anne Arundel County. Russell Wright, 1982.
- Page 22: Crisfield Historic District. Paul Touart, 1986.
- Page 24: Eightrupp Corn House at Susquehanna State Park, Harford County. Peter Morrill, Abby Hobbs, Casey Pecoraro, Heather Barrett, Barbara Fisher, and Jessica French, 2018.
- Page 25: Union Square Historic District, Baltimore. Ron Andrews, 1983.
- Page 27: Dover Bridge across Choptank River, Talbot and Caroline Counties. Hughes Co. Photographers, 1933.
- Page 28: St. James' Anglican Church, Anne Arundel County. Carl Lounsbury, 1997.
- Page 31: Rural landscape, Allegany County. Heather Barrett, 2018. Silo at Crossland Farm, Allegany County. Heather Barrett, 2018.
- Page 33: Joseph D. Lyons House, first floor hall, Calvert County, Doug Barber, 1997.
- Page 34: Joseph D. Lyons House, front elevation, Calvert County, Doug Barber, 1997. Joseph D. Lyons House, living room, Calvert County, Doug Barber, 1997.
- Page 35: Joseph D. Lyons House, outbuildings, Calvert County, Doug Barber, 1997. Joseph D. Lyons House, general view, Calvert County, Doug Barber, 1997.
- Page 36: Joseph D. Lyons House, Calvert County, Resource sketch map. J. Richard Rivoire, 1996.
- Page 39: Araby, Charles County. Willie Graham, 2018.
- Page 40: Field recording at Poplar Hill, Prince George's County. Casey Pecoraro, 2018.
- Page 41: Field recording at Sarum, Charles County. Casey Pecoraro, 2018.
- Page 42: Sotterley, St. Mary's County. Willie Graham, 2018.
- Page 43: Riversdale, stair, Prince George's County. Marcia Miller, 2018.
- Page 45: Compton Bassett, dairy, Prince George's County. Willie Graham, 2019.
- Page 48: Cloverfields, Queen Anne's County. Marcia Miller, 2019.

Page 49: Log Cabin at St. Joseph's College & Mother Seton Shrine, Frederick County. Amanda Apple, 2015.

Page 50: Drum Point Lighthouse, St. Michaels. Marcia Miller, 1993.

Page 53: St. Michaels, Area of Potential Effect for Proposed Bypass, John Milner Associates, 1999.

Page 54: Crisfield Historic District, Paul Touart, 1986.

Page 56: Belle Chance, Andrews Air Force Base, Prince George's County, Susan Pearl, 1986.

Page 57: Conococheague Aqueduct Construction, Washington County. Natalie Loukianoff, 2018.

Page 58: Barrow House, Cecil County. Ken Short, Heather Barrett, and Casey Pecoraro, 2018.

Page 59: Kenah House, Prince George's County. Thomas Gross, 2016.

Page 60: Galesville Rosenwald School, Anne Arundel County. Heather Barrett, 2018.

Page 61: 9900 Colesville Road, Polychrome Historic District, Silver Spring. Constance Terry, 1993.  
Mar-Va Theater, Pocomoke City. Paul Touart, 1993.

Page 63: Bond-Simms Barn Complex, St. Mary's County. Willie Graham, 2018.

Page 64: Hitchcock Tunnel, Garrett County. Donna Ware, 1981.



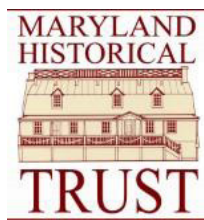

Maryland Historical Trust  
Maryland Department of Planning  
100 Community Place  
Crownsville, Maryland 21032-2023